

Sight Glasses

Assembly Instructions

In-Line and In-Line Safety Sight Glasses (Basic Ordering Number 162 and 162S)

⚠ WARNING

Before servicing any installed sight glass, you must:

- depressurize the system
- purge the sight glass.

Disassembly

1. Place the **flange** on a flat surface.
2. Loosen the **inner jam nuts** using a 3/8 in. open-end wrench (up through 2.5 in. size) or 1/2 in. wrench (3 and 4 in. sizes).
3. Remove the **outer jam nuts**.
4. Remove the **flange**.
5. Safety sight glasses only (162S model) - remove the **safety shield**.
6. Remove the **gasket** and four **studs** with **inner jam nuts** still attached.
7. Lift the glass from the flange and remove the other gasket.

Reassembly

1. Clean the parts and inspect for wear prior to reassembly. Replace gaskets and glass as necessary.
2. Place the **flange** on a flat surface.
3. Install a **gasket** on the **flange**.
4. Set the **glass** on the **gasket**.
5. Install four **studs** with one **inner jam nut** on each **stud** end.
6. Place the other **gasket** on the **glass**.
7. Safety sight glasses only (162S model) - install **safety shield**.
8. Install the other **flange**.
9. Thread the **outer jam nuts** on the **studs** fingertight.

⚠ Caution

Do not have the inner jam nuts in contact with the flanges at this time. The sight glass may not seal properly if there is contact.

10. Torque the **outer jam nuts** in a cross pattern to the value specified in the table, using an open-end wrench to hold the outer jam nuts on the opposite flange stationary, 3/8 in. for up through 2.5 in. size, 1/2 in. for 3 and 4 in. sizes.

Size, in.	Torque, in. -lbs (N·m)
1	10 to 12 (1.1 to 1.3)
1.5	10 to 15 (1.1 to 1.7)
2	15 to 20 (1.7 to 2.2)
2.5	15 to 20 (1.7 to 2.2)
3	20 to 25 (2.2 to 2.8)
4	25 to 30 (2.8 to 3.4)

11. Tighten the **inner jam nuts** using an open-end wrench to secure the assembly.

Cleaning

Sight glasses can be cleaned-in-place or manually cleaned.

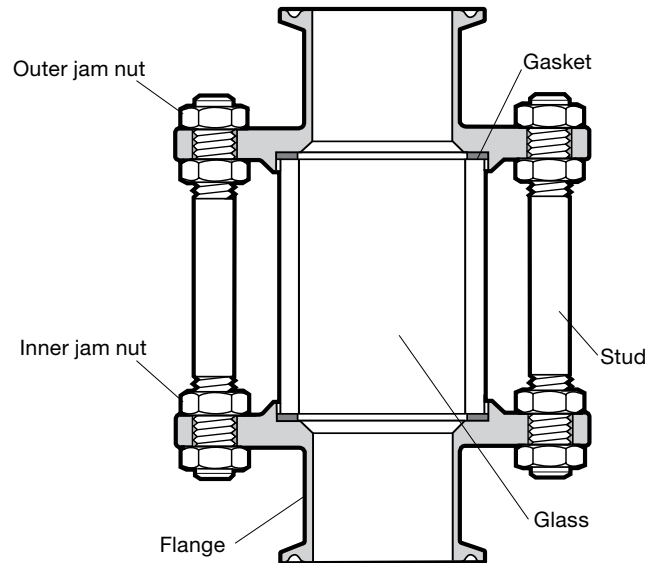

In-line Sight Glass

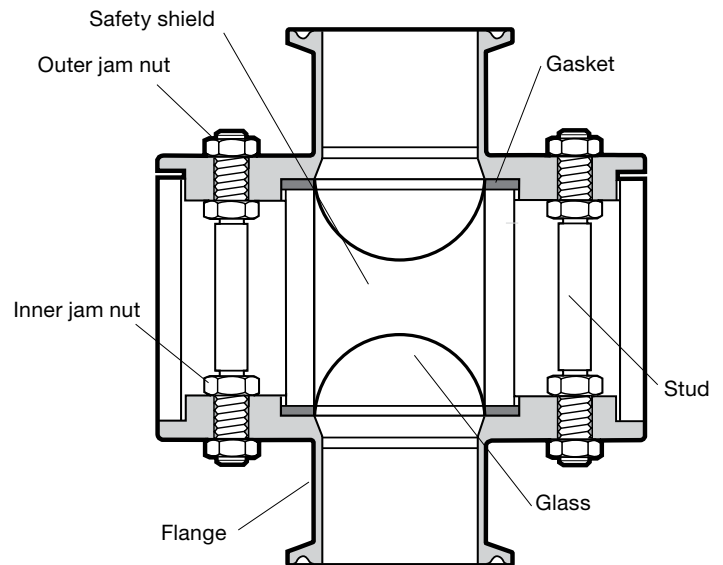

In-line Safety Sight Glass

Sight Glass and Weld-In Sight Glass Assemblies (Basic Ordering Number JCD54 and JCD54W)

Cleaning

Sight glasses can be cleaned-in-place or manually cleaned.

Disassembly

1. Remove one of the **Kwik clamps**.
2. Remove the **glass disc** and **fixture gasket** from the **retaining cup**.
3. Remove the **Kwik-clamp gasket** from the **body**.
4. Clean parts and inspect for wear prior to reassembly. Replace gaskets and glass discs as necessary.

Reassembly

1. Install a **fixture gasket** and **glass disc** into the **retaining cup**.
2. Install a **Kwik-clamp gasket** on the **body**.
3. Install the Kwik clamp assembly onto the **sight glass body**. Install and tighten the **clamp**.

