

Pick the Proper Hose

By Patrick Werrlein, Swagelok Company

Swagelok®
Swagelok Allentown

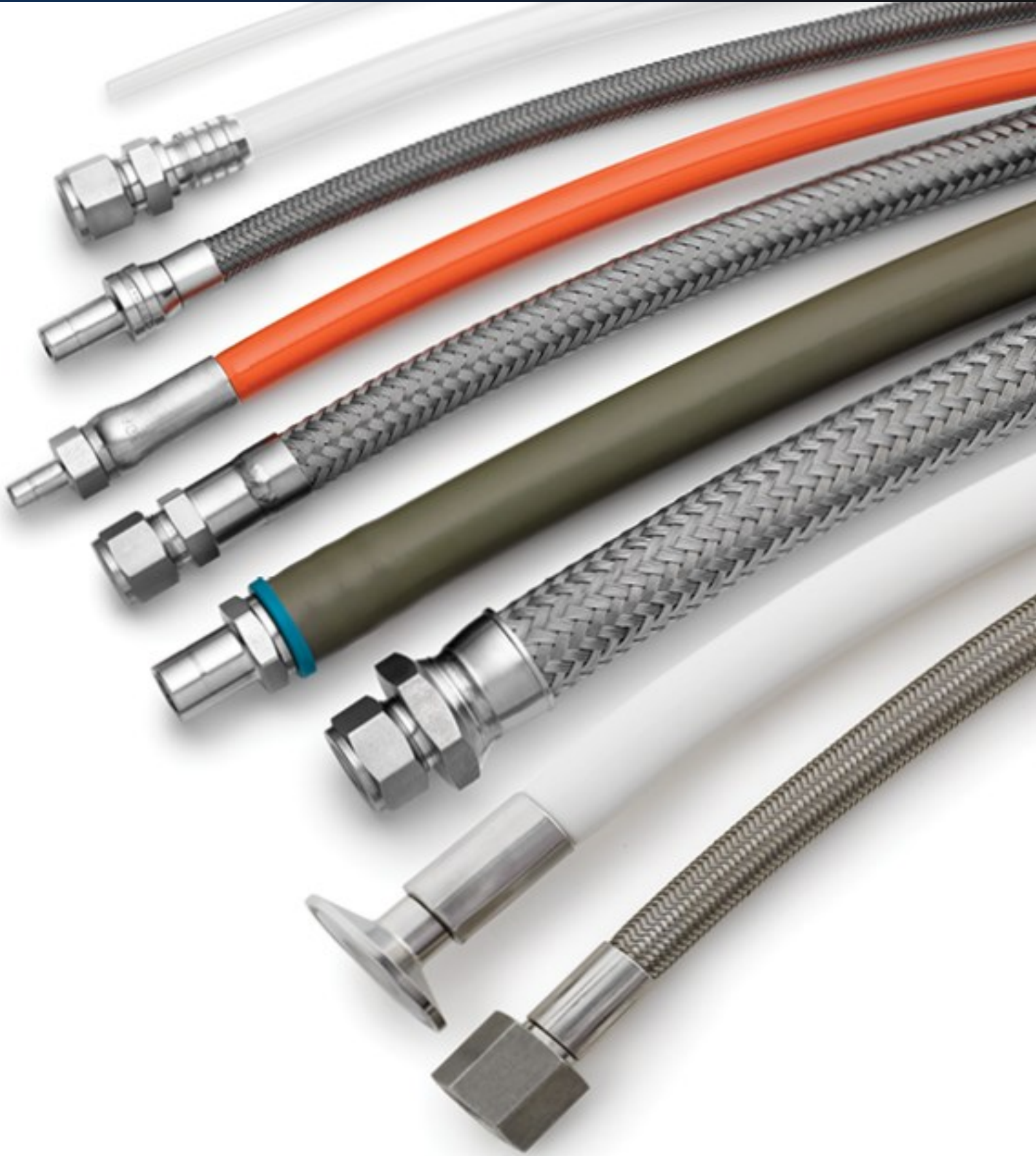

Pick the Proper Hose

The right hose keeps your process performing safely and cost effectively. The wrong hose could undermine your operations, put personnel at risk and compromise your bottom-line — sometimes without you being aware of it.

For example, an improperly chosen hose may kink. This permanent buckling disrupts system media flow and creates a rupture threat. However, kinked hoses aren't easily detected and so afflict many plants.

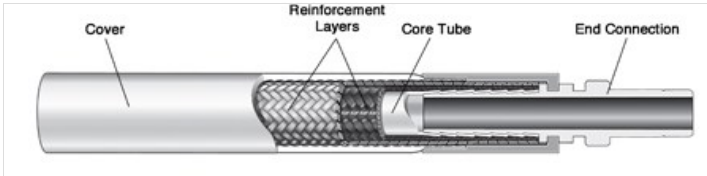

Hose Parts

Figure 1. Hoses generally consist of four main components.

Unfortunately, plants often treat hose selection as an afterthought. So, here, we'll look at the proper approach. You must consider a variety of process requirements — e.g., temperature, pressure, flow, chemical compatibility and drainability. In addition, selecting wisely also requires evaluating hose longevity, maintenance and replacement costs, and other cost-of-ownership factors.

Selection starts with an understanding of the four main parts of a hose (**Figure 1**):

1. core tube material and construction;
2. reinforcement layers;
3. covers; and
4. end connections.

Core Tube Material and Construction

When choosing a hose, begin with the core tube, which is the hose's innermost layer, the one that contacts the system media.

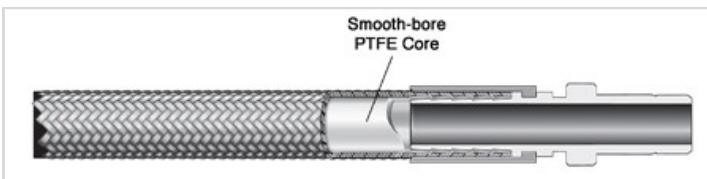

Smooth-Bore Core

Figure 2. Lack of wall irregularities allows more-precise flow control.

Answer some basic questions (with the help of product catalogs and your sales and service representative):

- Is the material chemically compatible with the system media? Will it corrode or deteriorate over time?

- Can it tolerate the temperature range of the system media?
- Will the material adequately prevent or limit permeation and absorption? This may not be an issue in your application. If it is, though, understand that permeation and absorption can occur in all materials, even metals; so this question is one of degree.
- Will the core material withstand the cleaning practices for your system — temperature, pressure and any solvents and cleaning agents employed?

Core tubes come in a variety of materials and constructions:

Metal cores (commonly type 316L stainless steel) are a good choice for general needs. They usually are rated for -325°F-850°F (-200°C-454°C), which makes them an especially good choice — sometimes the only choice — for system media at extreme temperatures.

A metal core also makes sense to minimize permeation or absorption. However, it can corrode when contacting highly caustic or acidic media.

Silicone historically has served for sanitary applications. It typically can handle -65°F-500°F (-53°C-315°C) and is flexible.

However, silicone is incompatible with common solvents and has limited chemical compatibility overall. In addition, it is absorptive, which can lead to contamination if fluid absorbed into the tube walls later leaches out into media currently in the system. Removing the absorbed fluid often isn't possible.

Fluoropolymer cores are becoming the material of choice for sanitary applications. PTFE, PFA, and FEP are three common fluoropolymers, with a typical range of -65°F-450°F (-53°C-230°C).

Fluoropolymer cores are the most chemically inert ones available. They are non-aging, non-stick, easy to clean, and can withstand repetitive steam cleaning. Like metal, they also have a low absorption rate. In addition, today's fluoropolymer cores boast flexibility comparable to that of silicone. However, fluoropolymers are highly permeable.

With many fluoropolymer hoses, you can specify a carbon-black-filled core if your fluid requires static dissipation. Static sparking can damage hose and pose a safety hazard.

Thermoplastic (nylon) hoses can contain high pressures and often are chosen for hydraulic applications. They are available in sizes up to one

inch and have a typical range of -40°F-200°F (-40°C -93°C).

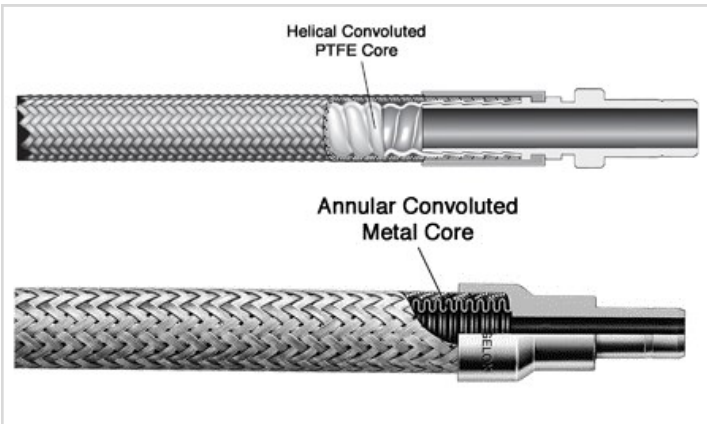

Convoluted Cores

Figure 3. Helical design (top) has a single spiral while annular design (bottom) uses a series of connected rings.

Rubber hoses provide a temperature range comparable to thermoplastic ones. They only can handle low pressure but can be crushed without permanent damage. So, such hoses provide an economical option for general-purpose duties. While the other types of hoses typically are available only in diameters up to 2 inches, rubber hoses also come in larger sizes.

Besides tube material, you must consider wall construction — whether the hose should have a smooth-bore core or convoluted core that allows it to bend like a flexible straw. Your application's requirement for hose bendability as well as pressure, flow and drainability needs will guide your decision.

Choose smooth bore (Figure 2) if precise flow control is a priority — it lacks wall irregularities that can cause interruptions. Smooth bore also promotes drainability. Its primary disadvantage is kinking, particularly in larger diameters. Reinforcement layers, discussed later, can help prevent kinking. All core materials except for metal are offered in smooth bore.

Convoluted cores are best when flexibility is the priority. The walls of the tube are folded in a pattern that increases the hose's ability to bend without kinking. Metal and fluoropolymer cores are offered with convolutions.

Convoluted cores come in two types — helical and annular. The helical design, found primarily in fluoropolymer cores, is a single convolution that spirals down the length of the hose

(Figure 3 top). The annular design, typical in metal cores, consists of a series of connected rings (Figure 3 bottom).

Helical convolutions promote better flow downstream than annular ones; so, choose a helical design when flow maintenance and drainability are important. Annular metal cores come with deep convolutions and so provide maximum flexibility. However, convoluted metal hoses don't suit operations with repetitive movements because such movements can cause metal fatigue and breakage.

Reinforcement Layers

These are your next consideration. In most cases a flexible, stainless-steel woven braid reinforces the core tube to improve pressure containment and flexibility in the hose. Ensure your hose has an acceptable pressure rating.

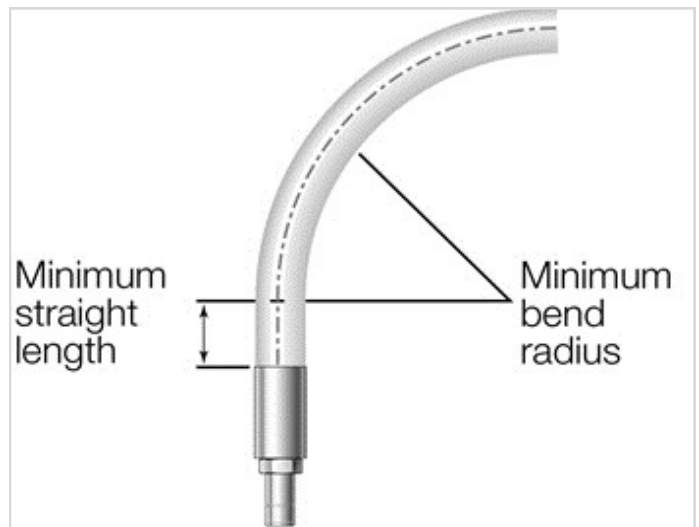

Bend Radius

Figure 4. Every hose has a minimum radius that it can be bent.

You also must consider flexibility. To do so, you must understand that every hose has a minimum bend radius, which measures how far the hose can bend before kinking (Figure 4). Minimum bend radii are given in industrial hose literature.

However, many people don't realize that flexibility involves more than bend radius. You must consider the force required to bend an unpressurized hose. A hose with a good bend radius isn't much help if it's so stiff that personnel can't bend or have difficulty installing it. Will it slow down or break a machine in a dynamic operation?

Force-to-bend is just as important as bend radius but not as easy to measure — and hose manufacturers don't offer guidelines. So, if feasible, test hose samples with your own hands.

Covers

Next, you must decide if your hose should have a cover — and, if so, what kind. A cover is an outer layer that protects underlying layers, personnel and surrounding equipment. Covers come in materials such as silicone and rubber and are integral to the hose.

Silicone covers are most common for general purposes. They help prevent abrasion from fraying the braids in stainless-steel reinforcement layers, which can weaken the hose and create threats of bursting and personal injury. Silicone covers can afford enhanced burn protection for personnel who grab or bump hoses carrying very hot fluid. They also provide insulation, helping to maintain process temperature.

Silicone covers are a particularly good choice for sanitary applications. Their smoothness eases wash down. And covering the stainless-steel reinforcement layer eliminates bacterial buildup in the braid's crevices.



Fire Jacket

Figure 5. Fiberglass cover coated with silicone rubber can reduce burn risks.

You'll also find covers for specialty applications. For maximum burn protection, consider a fire jacket, a fiberglass cover coated in silicone rubber (**Figure 5**). Keep in mind, however, that fire jackets connect loosely to the hose and can snag and rip. Another cover type, bend restrictors, help keep hose from being bent beyond its bend radius.

On the downside, covers add cost, restrict flexibility and make the hose larger, a concern for routing and angling. In most applications, the goal in cover selection is to achieve the smallest diameter while not decreasing hose flexibility.

End Connections

Most leaks occur at the end connections, which usually are made of metal. The performance of a hose assembly largely depends on the hose maker's ability to attach end connections, so choose a reputable manufacturer.

Metal hoses come with a variety of end-connection choices. The connections are welded, which completely and permanently seals the product.

For fluoropolymer hoses, you must select between swaging and crimping. Swaging puts pressure on the hose itself, while crimping squeezes the end connection. Both methods are widely accepted but crimping has a slight advantage in that it's less likely to damage the hose because the pressure is exerted in a carefully controlled manner.

Many chemical applications require use of fluoropolymers on wetted end connections. The hose industry has devised some creative solutions. One is "flare-through" — the fluoropolymer core tube is flared such that it covers the entire inner surface of the metal end connection. This avoids a step or drop between the core tube and fitting, ensuring smooth flow. However, flare-through is costly and fragile and isn't recommended for high temperature applications.

Another common and lower-cost solution is called "encapsulation" — fluoropolymer entirely encapsulates the stainless-steel end connection, inside and out. However, this reduces orifice size, raising the possibility of decreased flow and entrapment.

Select the Right Hose

As we've discussed, you must carefully match your application's requirements such as temperature, pressure, flow and flexibility to the four key hose components — core tube material and wall construction, reinforcement layers, covers and end connections. You will find many options for each component. A manufacturer's representative and product catalogs can help guide you to the right choice.

Make the Most of Hose

Consider these three tips:

1. Use identification to your advantage. Customize your hoses with tags or text. Personnel then can see at a glance the hose's function, which enhances safety and plant efficiency. Proper identification also allows fast and accurate ordering of replacement hose. Color-coded silicone covers — e.g., one color for hoses going to the process and another for hoses coming from it — can enable identifying hose function from a distance.

2. Insist on traceability. Select from manufacturers that offer fully traceable products. Lot numbers on hose assemblies, including fluoropolymer core tubes and stainless-steel end connections, allow the manufacturer to better limit your potential loss in the event of a recall. For example, if you get a bad hose in an order of 100, traceability enables the manufacturer to determine if the problem goes beyond the one bad hose — without this knowledge, you might automatically replace all 100 hoses.

3. Think about cost of ownership. Make decisions based on the true cost of a hose — i.e., the purchase price plus the cost of owning and maintaining or replacing the assembly over time. All hoses wear out. Determine how often you likely will replace the hose. Calculate the cost of replacement parts, labor and downtime.

Additional Resources

As you move forward with your hose purchase, please reach out to us if you need assistance:

(610) 799-9001

info@allentown.swagelok.com



“Swagelok® - The Right Hose with the Right End Connections” by Swagelok Company, from YouTube. [Access >>](#)

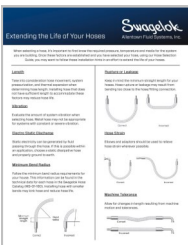

“Extending the Life of Your Hoses” by Swagelok Allentown. [Download >>](#)



Swagelok Allentown

4245 Independence Drive

Schnecksville, PA 18078

Phone: (610) 799-9001

Fax: (610) 799-3777

info@allentown.swagelok.com

<http://allentown.swagelok.com>

Warranty Information

Swagelok products are backed by The Swagelok Limited Lifetime Warranty. For a copy, visit Swagelok.com or contact your authorized Swagelok representative, listed above.

Safe Product Selection

When selecting a product, the total system design must be considered to ensure safe, trouble-free performance. Function, material compatibility, adequate ratings, proper installation, operation, and maintenance are the responsibilities of the system designer and user.

Swagelok[®]
Swagelok Allentown