



Swagelok®

60 SERIES BALL VALVES

Swagelok®



DESIGNED FOR RELIABILITY AND LOW MAINTENANCE

Swagelok combined a number of distinct features in developing the 60 series ball valve to create a very robust, reliable valve that is **suitable for a wide range of systems and applications.**

60 SERIES PRODUCT OVERVIEW: Gain a general understanding of our three-piece ball valve

PERFORMANCE AND DESIGN: Take a deep dive into the specific features and benefits of the valve's design

SPECIAL APPLICATION VALVES: See the extended line of special application valves available

AUTOMATION OPTIONS: Explore our line of actuators to transform your valve from manual operation to automatic

CUSTOMIZATION: Discover the options available to create a custom 60 series assembled product



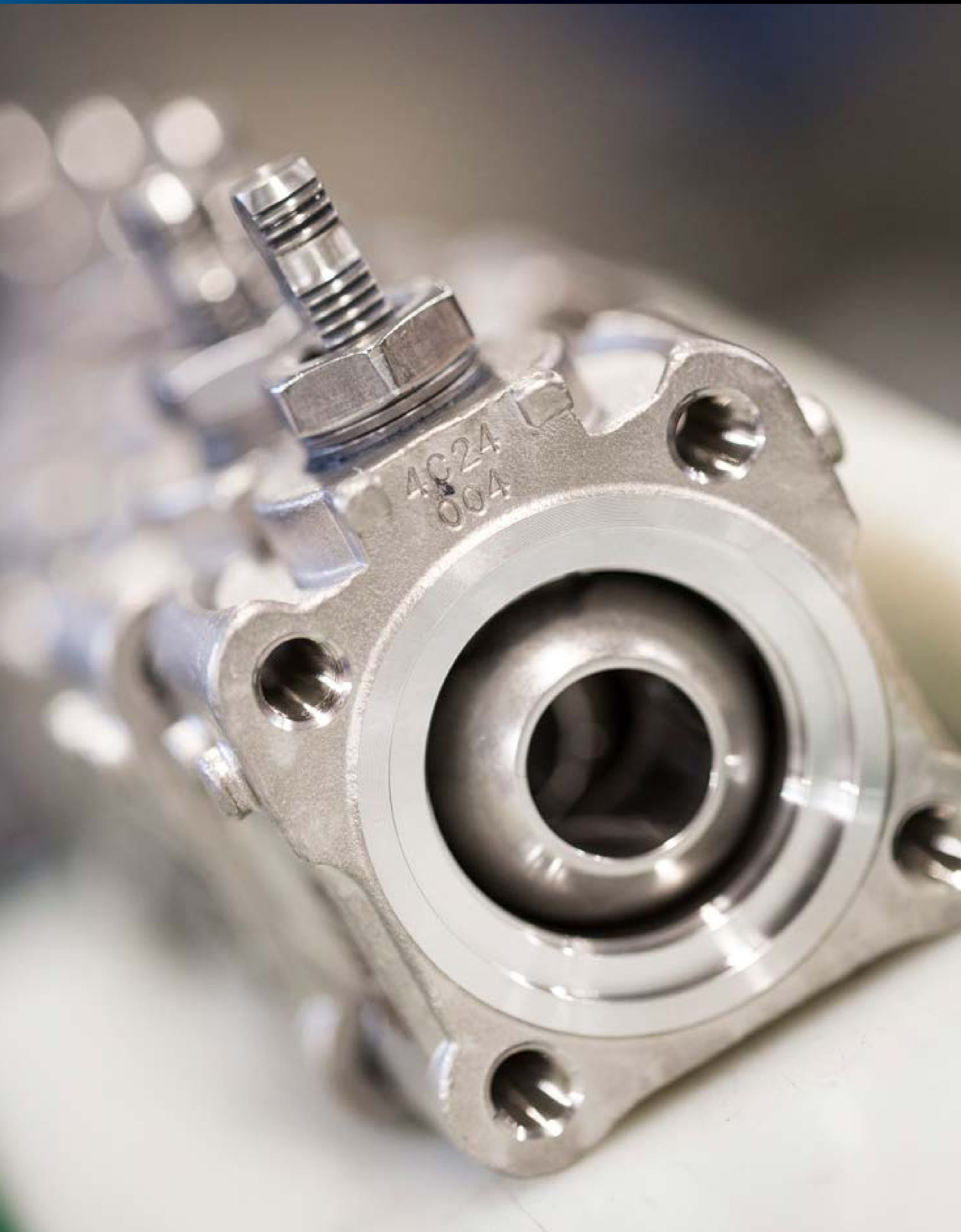

60 SERIES AT A GLANCE

- Designed to be operated in a **fully open or fully closed position**
- End connections sizes range from **1/8 to 2 in.** and 6 to 25 mm with additional sizes available
- Temperature ratings from **-65 to 850°F** (-53 to 454°C)
- Standard working pressure **up to 2200 psig** (151 bar) with an option to increase to 3000 psig (206 bar)
- Stainless steel, brass, carbon steel, and special alloy materials available
- **Wide selection of seat materials** including:

Reinforced PTFE	Alloy X-750
Carbon/glass PTFE	PEEK
UHMWPE	Virgin PTFE
- Optional vent porting
- On-off (2-way) and switching (3-way valves)
- SC-11 cleaning available

END CONNECTION FLEXIBILITY

Swagelok 60 series ball valves are available with a **wide variety of end connections** to fit the needs of your specific applications.

Available end connections include:

- Swagelok® Tube Fitting
- Female Pipe Thread
- Tube and Pipe Socket Weld
- Pipe Butt Weld
- Tube Extensions
- VCO® and VCR® Face Seal Fitting
- Sanitary Fitting
- Mixed End Connections

For more information on end connection options, see the





A VARIETY OF HANDLES TO MEET YOUR NEEDS

Black lever handles come standard on 60 series ball valves, however there are several other handle options available:

- **Lever-Handle with Colored Sleeves** - blue, green, orange, red and yellow are available
- **Oval Handles** - standard sleeve color is orange but other colors are available
- **Locking Brackets for Lever and Oval Handles** - allow you to lock valves open or closed
- **Oval Latch-Lock Handles** - available for 63 and 65 series 2-way valves to lock valves open or closed
- **Extended Handles** - Two- and four-inch handle extensions available

SWING OUT DESIGN ENSURES EASE OF INLINE MAINTENANCE

Looking for a valve that can be maintained inline?

The swing-out design of the 4-bolt valves allows fast and easy maintenance with the valve inline.

Replacement seal kits are also available for applications that require them.



60 SERIES OPTIONS AND ACCESSORIES



LOW DEAD SPACE INSERTS

- Reduce fluid entrapment around the ball, stem, and seats while the valve is open or closed
- Made from carbon/glass reinforced PTFE
- Not for use on steam, thermal, or fire series valves



PANEL MOUNT KITS

- Vertical or horizontal mounting
- Can be installed on panels up to 3/16 in. for 62 series and 1/4 in. thick for 63, 65, 67, and 68 series
- Fit oval and lever handle
- Provide template for drilling holes

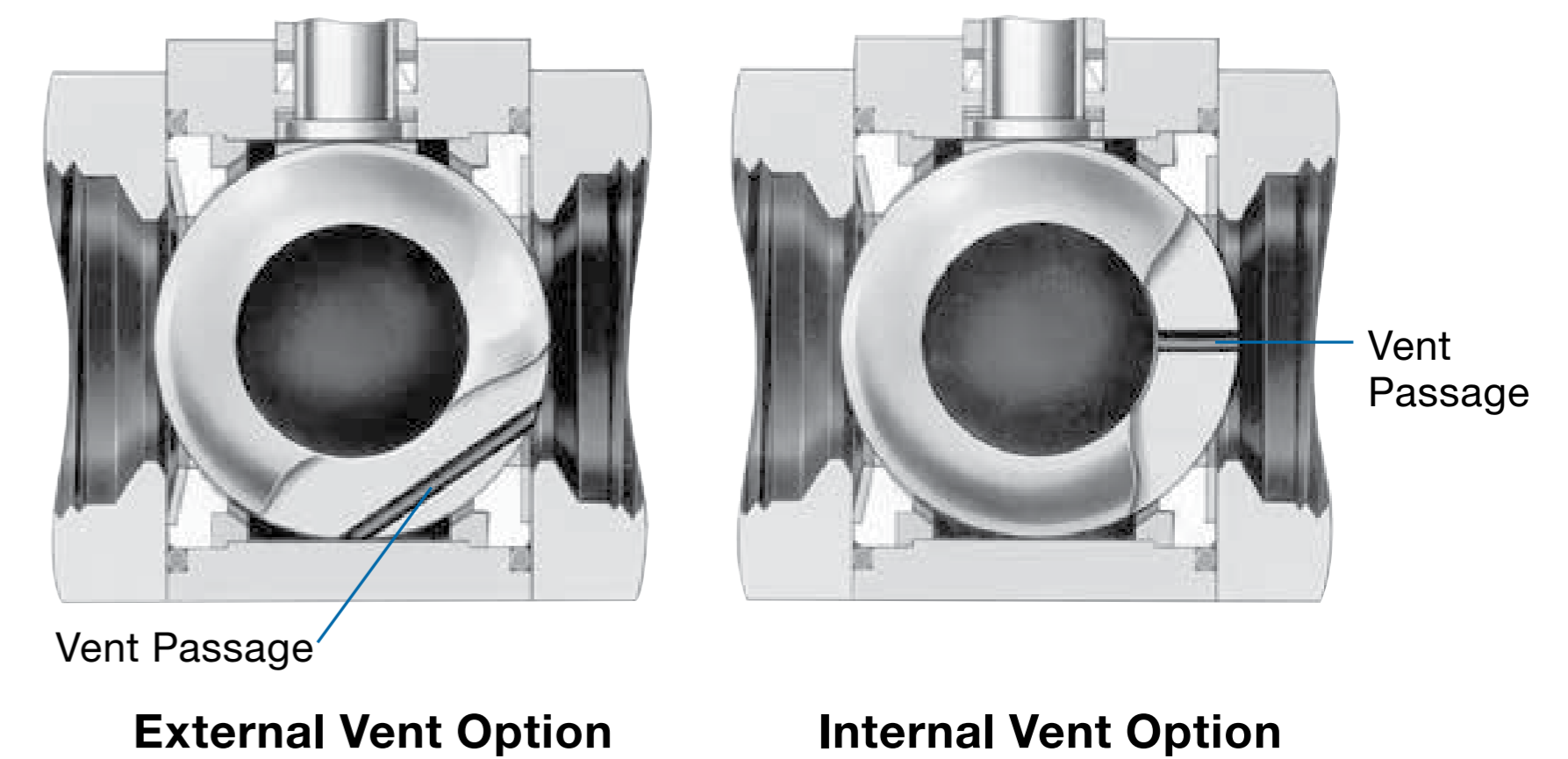

VENTED VALVES

- 2-way ball valves are available with either an internal or an external vent
- These vents are available for either upstream or downstream service

PERFORMANCE AND DESIGN

There are several key features of the 60 series ball valve that create **a distinct design difference** versus a traditional valve design.

- **Robust seat sealing** is accomplished by combining reinforced PTFE with additional seat support and a coned-disc spring.
- A **reliable stem seal** is achieved by a two-piece chevron packing live-loaded with Belleville springs.
- Safe operation is ensured through employing a **grounding spring** and **blow out proof stem**.
- Our **Limited Lifetime Warranty** shows our commitment to quality.

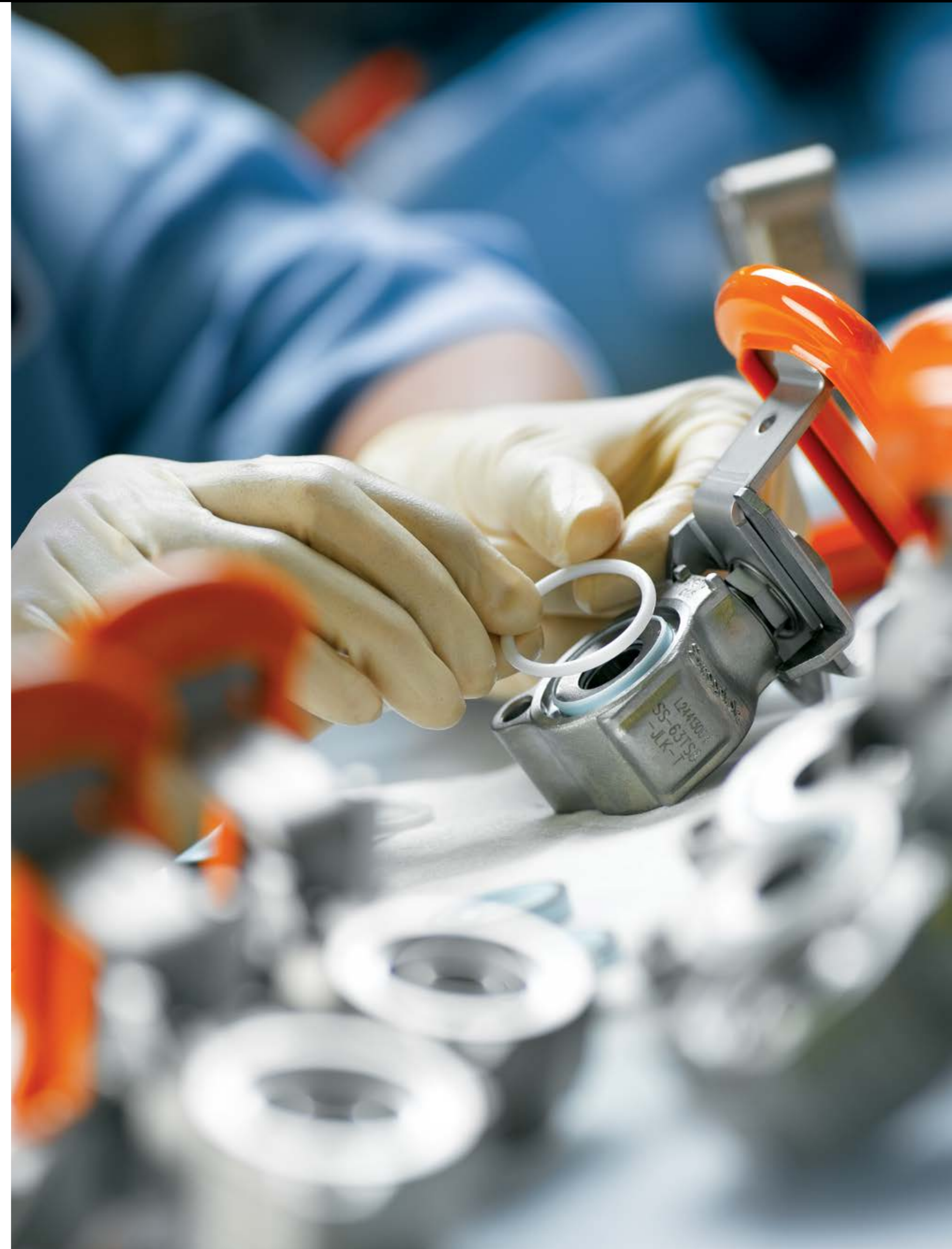

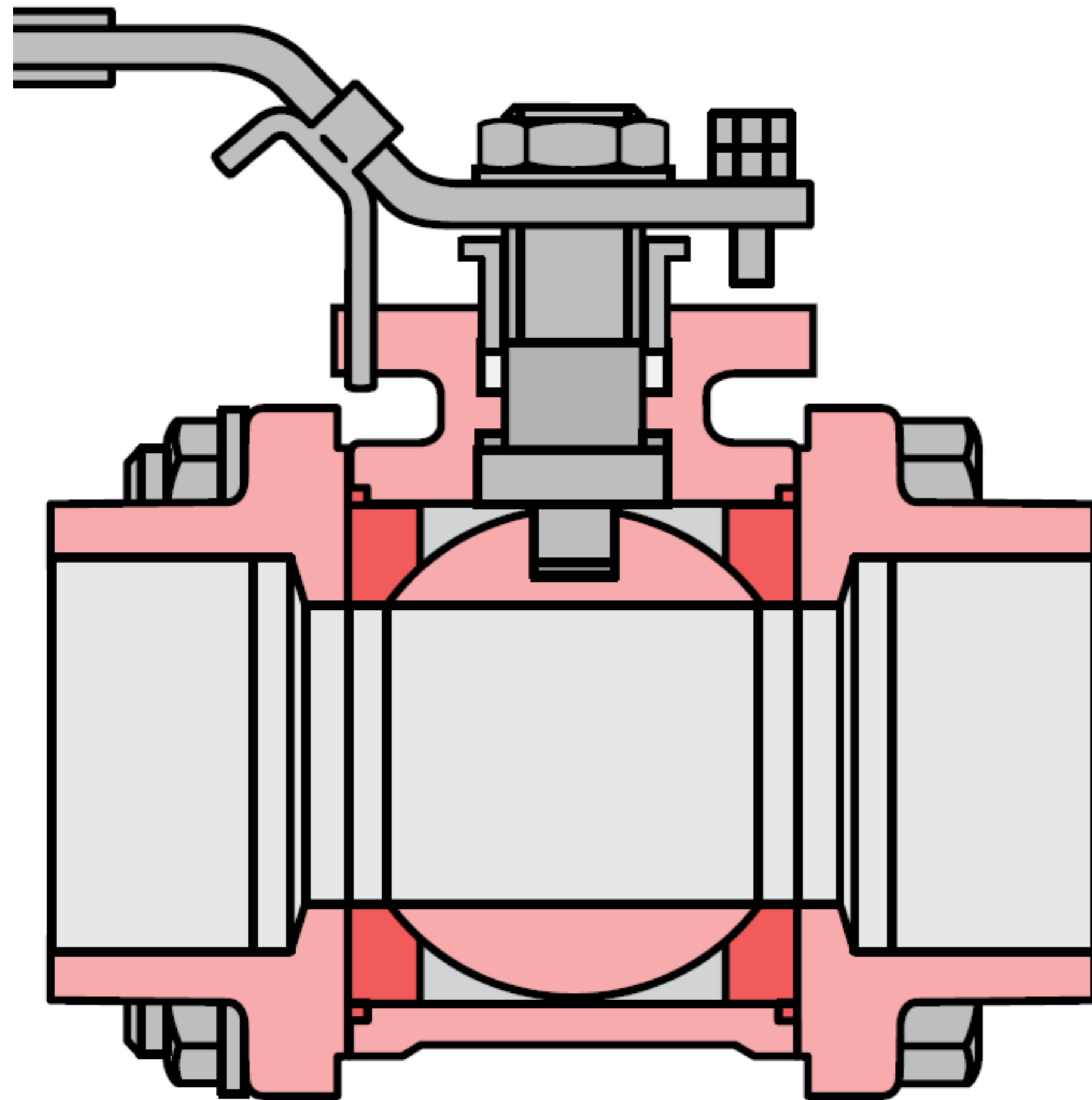

TRADITIONAL BALL VALVES

When you look at how PTFE is used in a traditional valve design, **large portions of the seat are unsupported.**

Since PTFE is unstable and tends to cold flow, temperature cycling, pressure changes, valve actuation and time in service will actually cause the PTFE to move into the orifice and body cavity.

This reduces the force of the seat against the ball and leaks can result.



Example of the effects of cold flow on PTFE that can result from operating a valve in the partially open position for a prolonged period of time, or if the valves are operated under pressure in the partially open position.

WHAT SWAGelok HAS DONE WITH THE 60 SERIES IS QUITE A BIT DIFFERENT.

A SEAT SEAL YOU CAN RELY ON FOR LEAK TIGHT SERVICE

To reinforce the PTFE, we use a **unique coned-disc spring-loaded seat** to compensate for seat wear, pressure and temperature changes. This design reduces seat wear from pressure surges and seals regardless of flow direction.

- The 60 series valve uses a **reinforced PTFE seat** for additional stability. This helps some, but alone it won't do the trick.
- Then, we employ a **support ring** in front of the seat to protect against seat bulge, premature wear, and deformation.
- The most important difference in the design of our valve is the use of the **coned-disc spring** behind the seat to achieve live-loading of the seat assembly

By greatly reducing the amount of PTFE that is unsupported, you can count on **excellent seat sealing performance**.

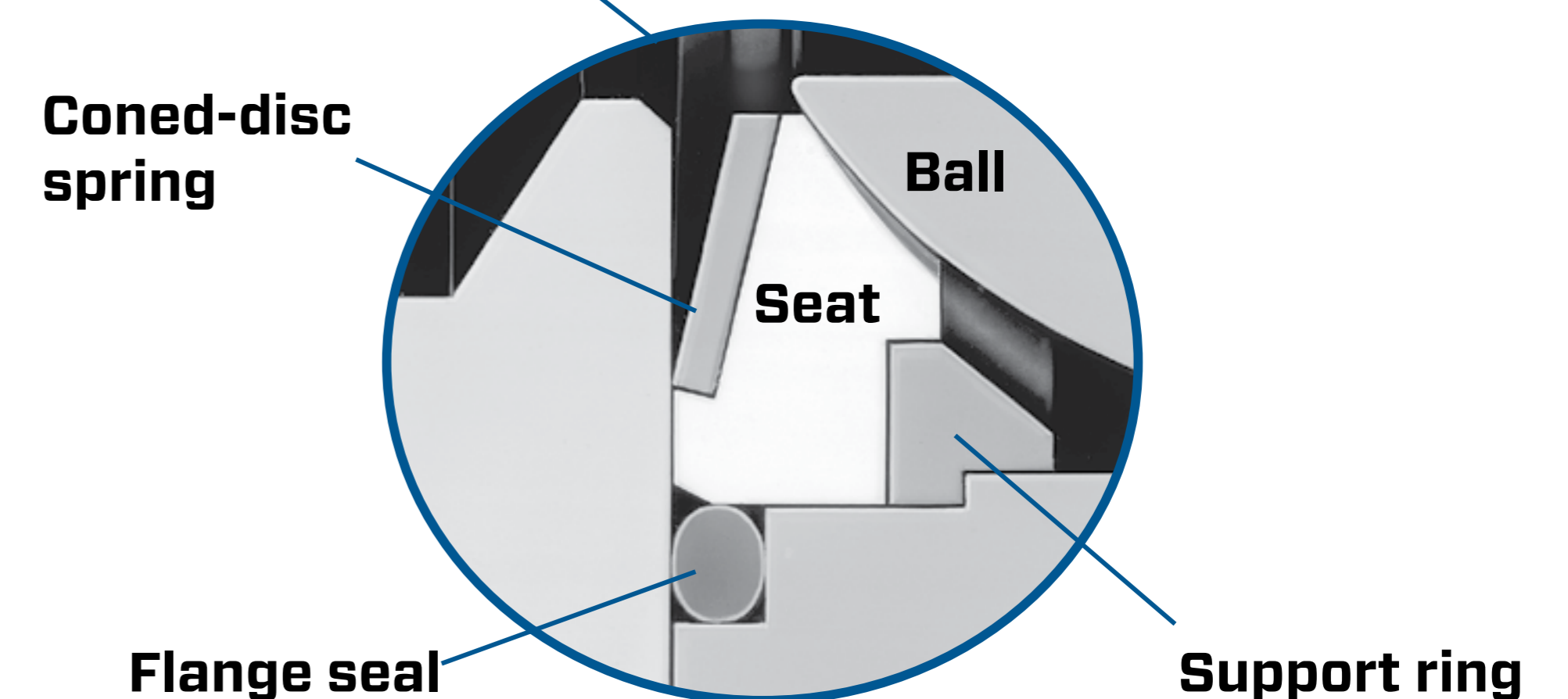
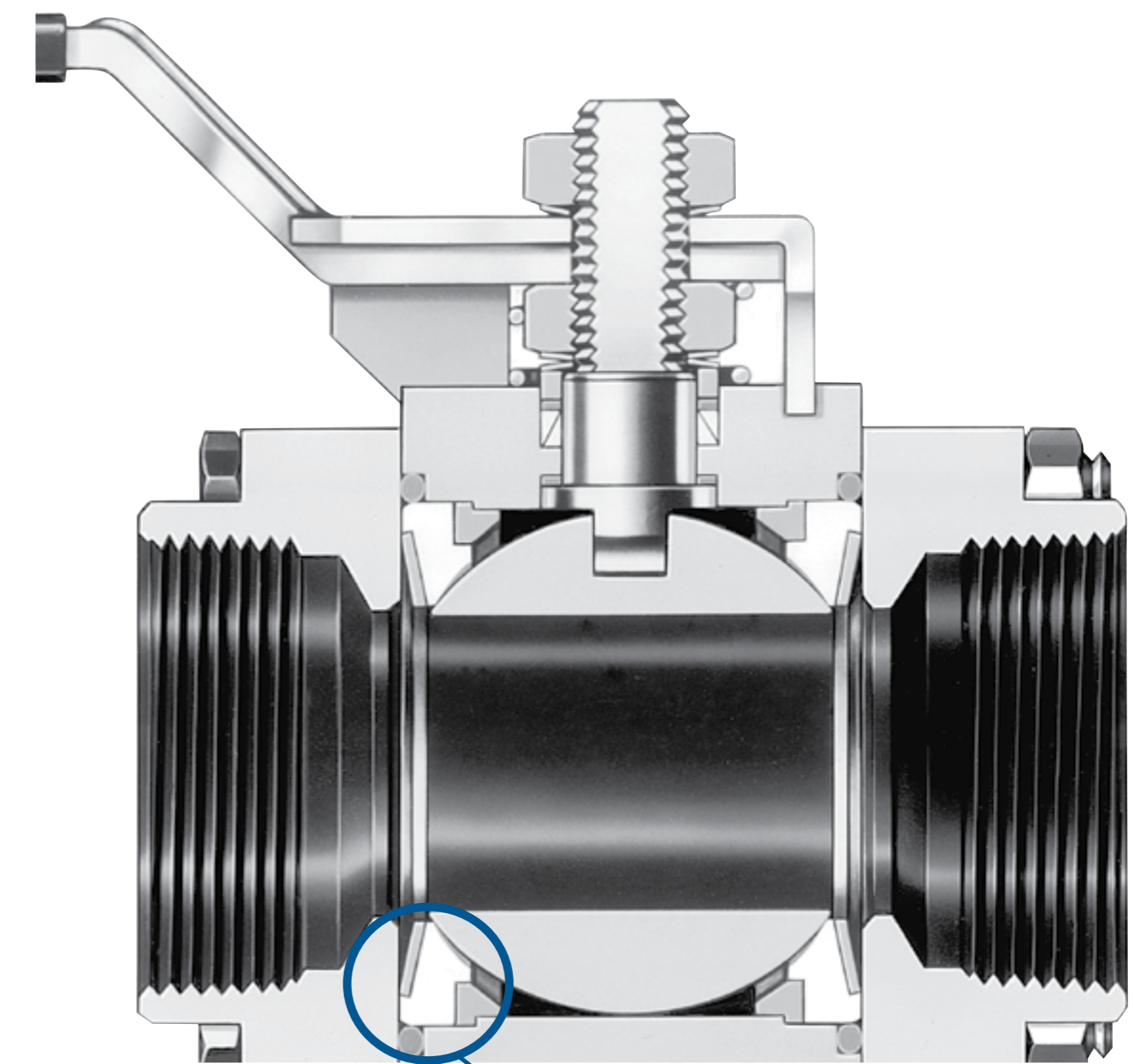

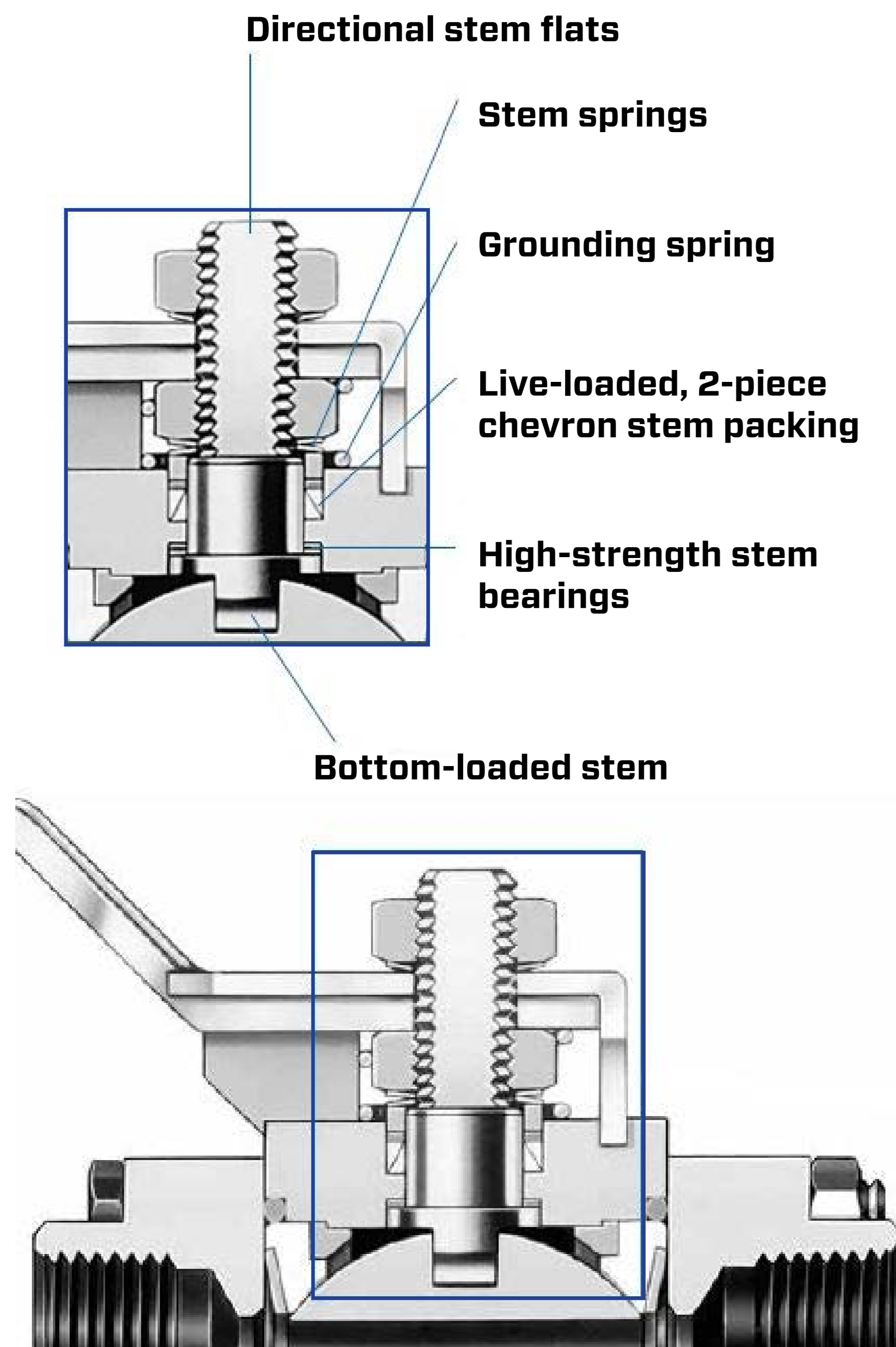

TECHNOLOGY TO ASSURE RELIABLE STEM SEALING

Equally important as the seat seal is how the 60 series achieves **a reliable stem seal**. There are two elements that are critical to creating the seal.

- We utilize a **two-piece chevron packing** enabling more of the torque that is applied to the packing nut to be distributed to the contact area with the stem and the body of the valve which is essential for sealing.
- The packing is backed up by a pair of **Belleville springs** to apply a consistent load on the packing creating a live-loaded stem assembly. The result? Long, trouble-free service over the life of the valve.

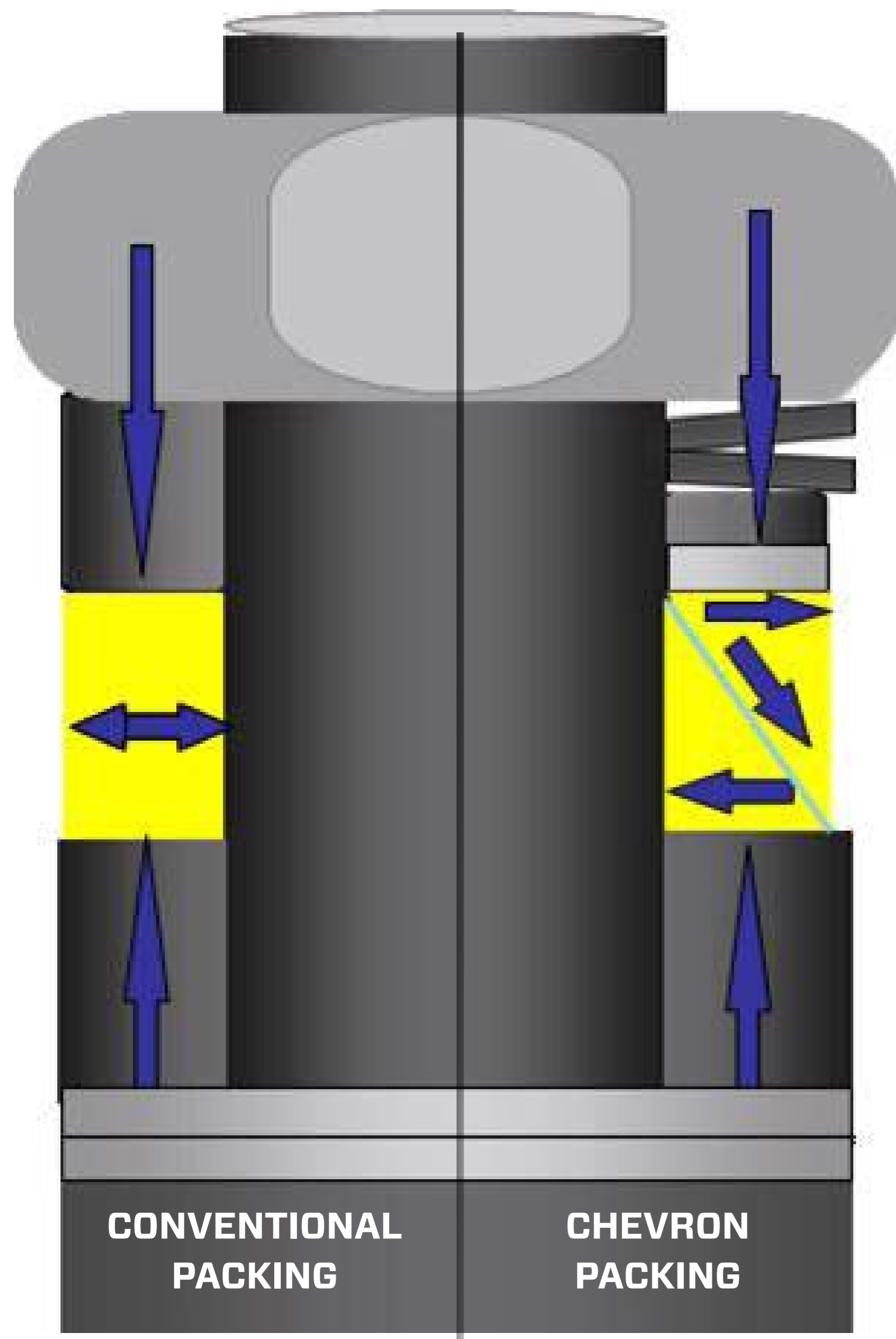

PACKING: TWO-PIECE CHEVRON VS. CONVENTIONAL

TWO-PIECE CHEVRON PACKING

The two-piece packing in the 60 series valve is what makes it truly “live-loaded.” The two pieces of chevron packing work together to create a robust stem and bonnet seal. As an axial load is applied from the stem nut, it is transmitted radially along the entire length of the packing to the stem resulting in a **low actuation torque**.

CONVENTIONAL PACKING

In a conventional seal, this load is transmitted at much higher loads with an uneven force distribution, ultimately leading to **lower cycle life and higher actuation torques** as compared to the chevron packing.

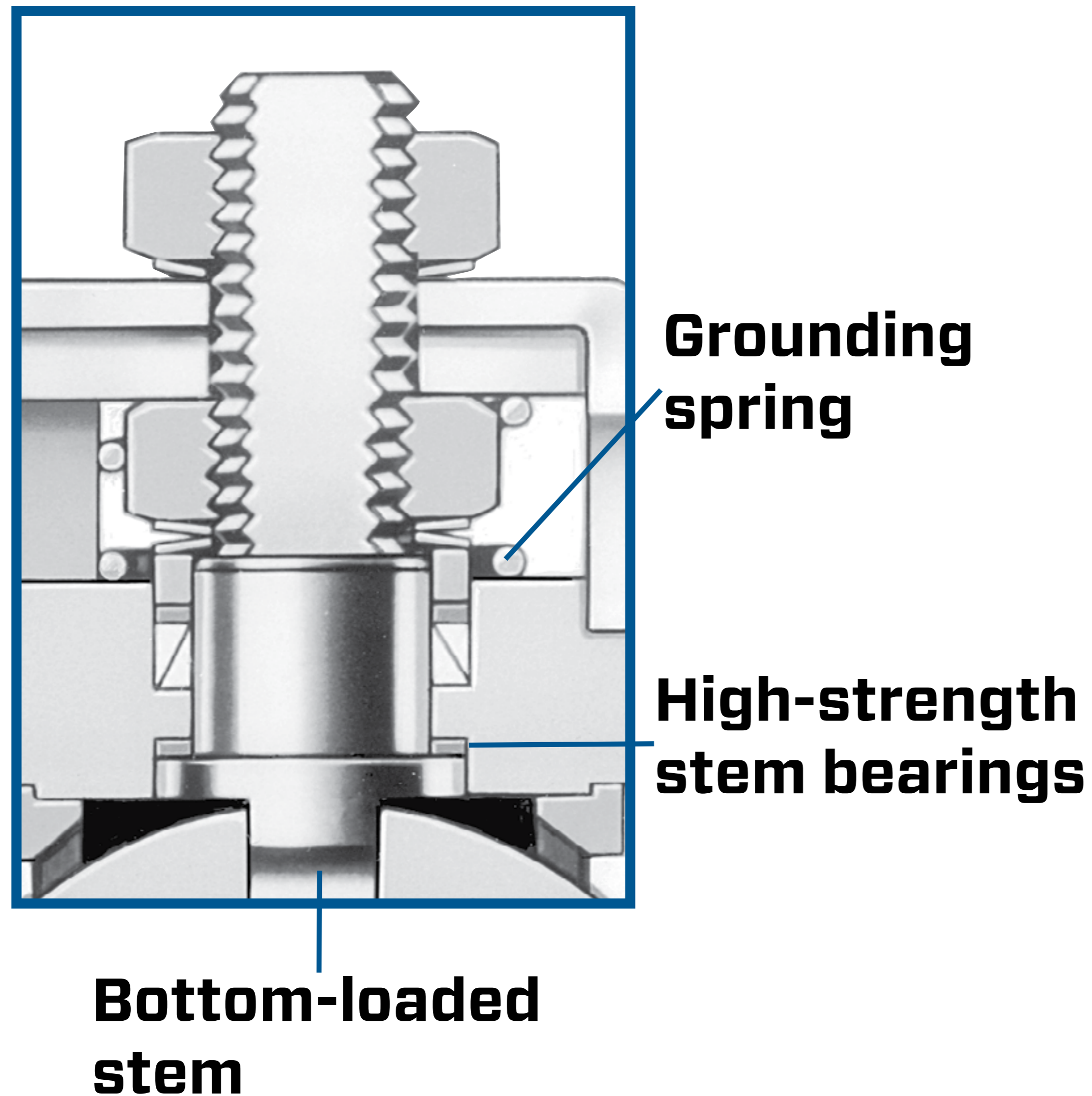

DESIGN FEATURES TO ENSURE SAFE VALVE OPERATION

- The 60 series ball valve employs a **blow out proof stem** that is assembled from the bottom which prevents stem blowout.
- High-strength **stem bearings** located between the stem shank and the body are designed to ensure smooth operation and long service life.
- The **grounding spring** provides a consistent ground to avoid any static build up during operation and use.
- The **stepped shoulder** prevents stem extraction.



A PROMISE AS STRONG AS OUR PRODUCTS

The **SWAGELOK LIMITED LIFETIME WARRANTY** demonstrates our relentless commitment to quality and our customers.

Every Swagelok product is backed by this promise for the life of the product.

**PROTECT YOUR FLUID SYSTEM
INVESTMENT FROM INSTALLATION TO
EVERYTHING AFTER.**

SPECIAL APPLICATION VALVES

In addition to the versatile general purpose 60 series valve, we also offer special 60 series valves designed for use in specific applications.

ALL WELDED

- W60T

4-BOLT SPECIAL APPLICATION

- Chlorine
- Low Temperature
- Rapid-Cycle Service

8-BOLT SPECIAL APPLICATION

- Steam
- Thermal
- Fire

TEST VALVE ASSEMBLY



ALL WELDED VALVES - W60T

Our all-welded valves incorporate the proven design features of the 2-way ball valve, all-welded body construction, and live-loaded packing to ensure total system fluid containment.

- Available in **1/2 in. and 1 in. sizes**
- Rated from **-20 to 450°F (-28 to 232°C)**
- A hydrostatic shell test is performed with pure water at 1.5 times the working pressure
- Full penetration welds provide one-piece body



CHLORINE SERVICE - C60V



Our chlorine series valve has a **carbon steel valve body with virgin PTFE seats and packing and an Alloy 400 ball**. An upstream ball vent prevents overpressurization in the ball and body when the valve is closed.

- Pressure rated to **300 psig (20.6)**
- Temperature ratings **-20 to 250°F (-28 to 121°C)**
- Designed in accordance with the guidelines set forth by the Chlorine Institute pamphlet 6, *Piping Systems for Dry Chlorine*
- Cleaned in mineral spirits followed by an aqueous cleaning solution containing a surfactant. All other wetted components are cleaned in accordance with SC-11 specification
- Commonly used in **wastewater treatment and pulp and paper applications** where the system media forms a corrosive acid when it gets wet, even from outside air

LOW TEMPERATURE SERVICE - L60 SERIES

The L60T series is a suitable option for low temperature applications.

- Temperature ratings as low as **-65 to 250°F (-53 to 121°C)**
- Pressure rated up to **3000 psig (206 bar)**
- Available in stainless steel and brass
- **A low temperature actuator is also available**
- Features the same design as the all-purpose 60 series valve except **the stem bearing is PEEK and the flange seal is Buna C**

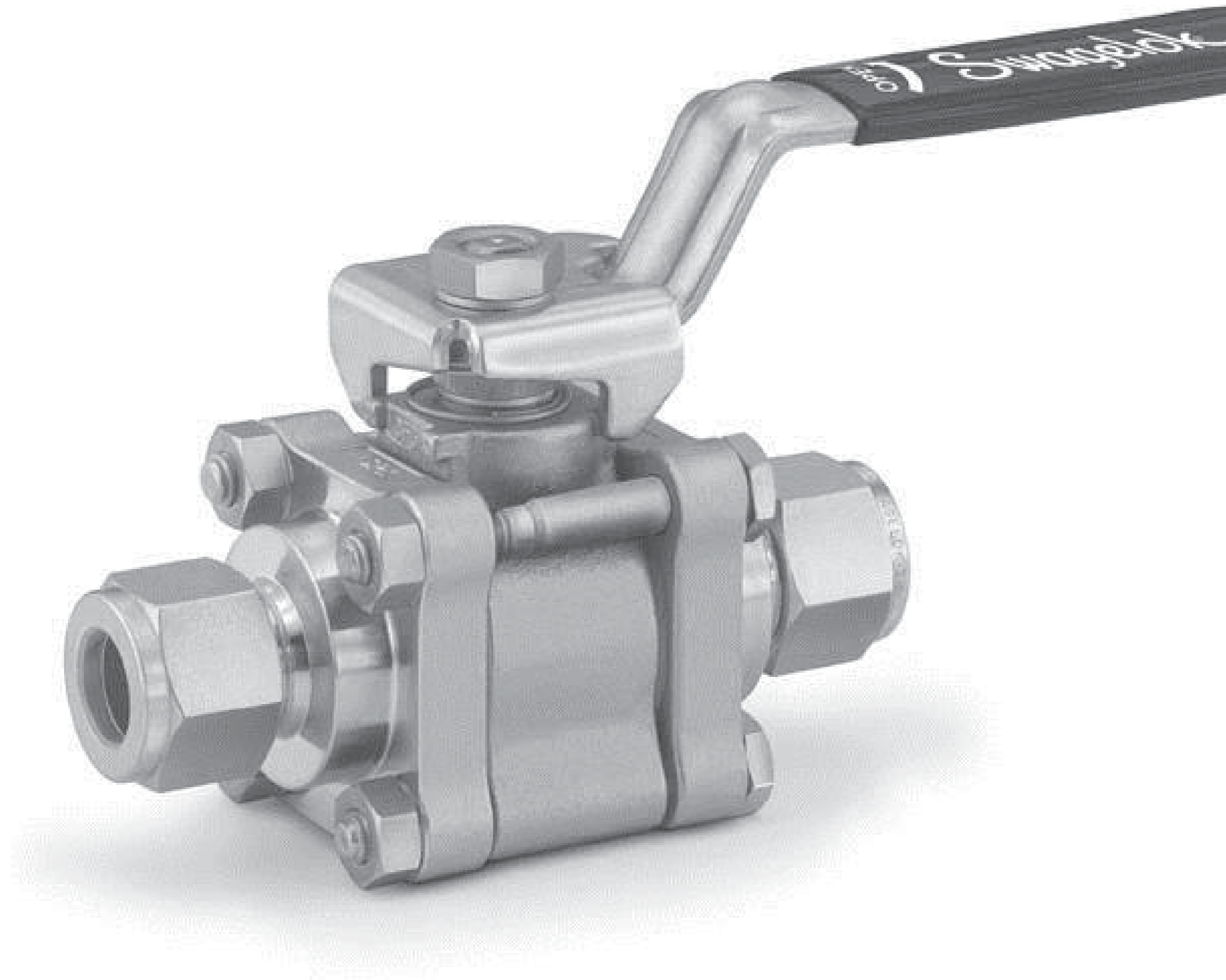

RAPID-CYCLE SERVICE - R60T

The R60T series is effective in applications requiring repetitive cycling of a valve or when packing adjustments may be difficult

- Pressure rated to **2200 psig (151 bar)**
- Temperature ratings **0 to 100°F (-17 to 37°C)**
- **O-ring stem seal**

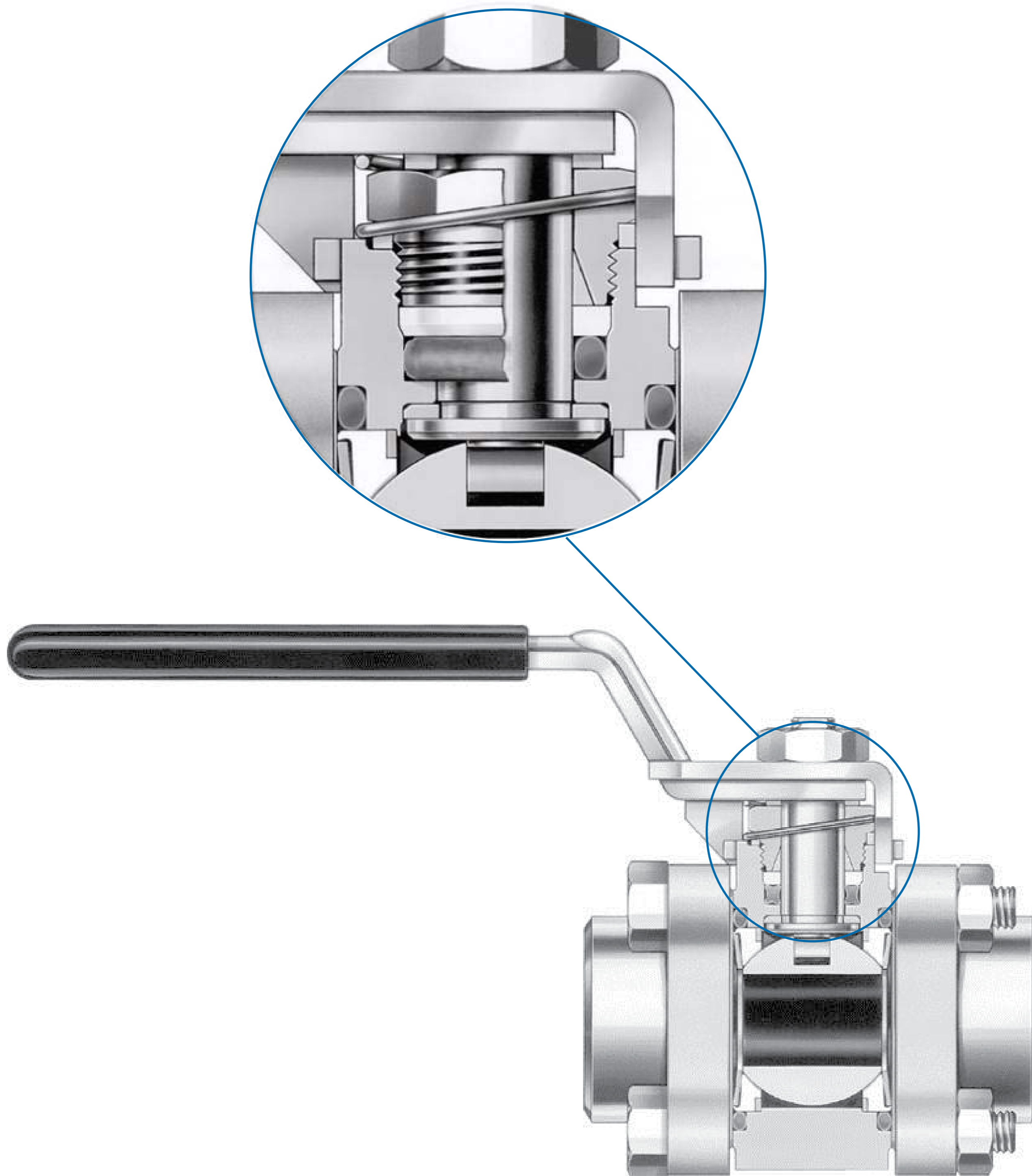

STEAM SERVICE - S60P SERIES

Our steam service ball valve can reduce lost energy, downtime, and safety hazards associated with leaking valves in a steam system.

Unlike conventional sealing methods, the patented design of the seats and stem packing in the steam series ball valves resist the erosive nature of steam, thus improving performance and enhancing safety.

- Temperature ratings as low as **-20 to 600°F (-28 to 315°C)**
- Pressure rated up to **2500 psig (172 bar)**
- Materials of construction: **8-bolt; PEEK stem bearing, packing, and seats** (which resist absorption of water and erosive damage of steam), and **Grafoil flange seals**
- **Designed to resist erosive properties of steam and water**

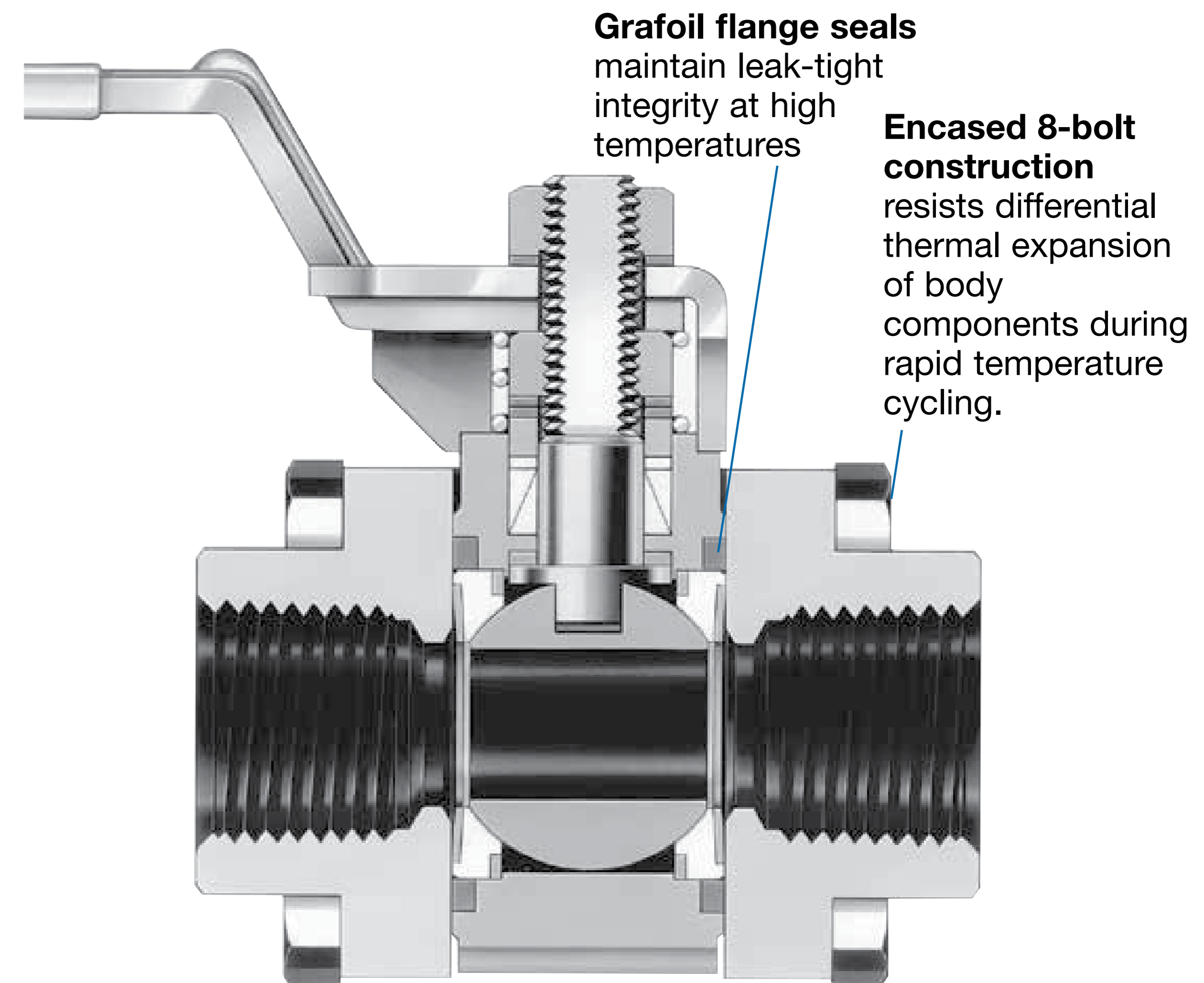

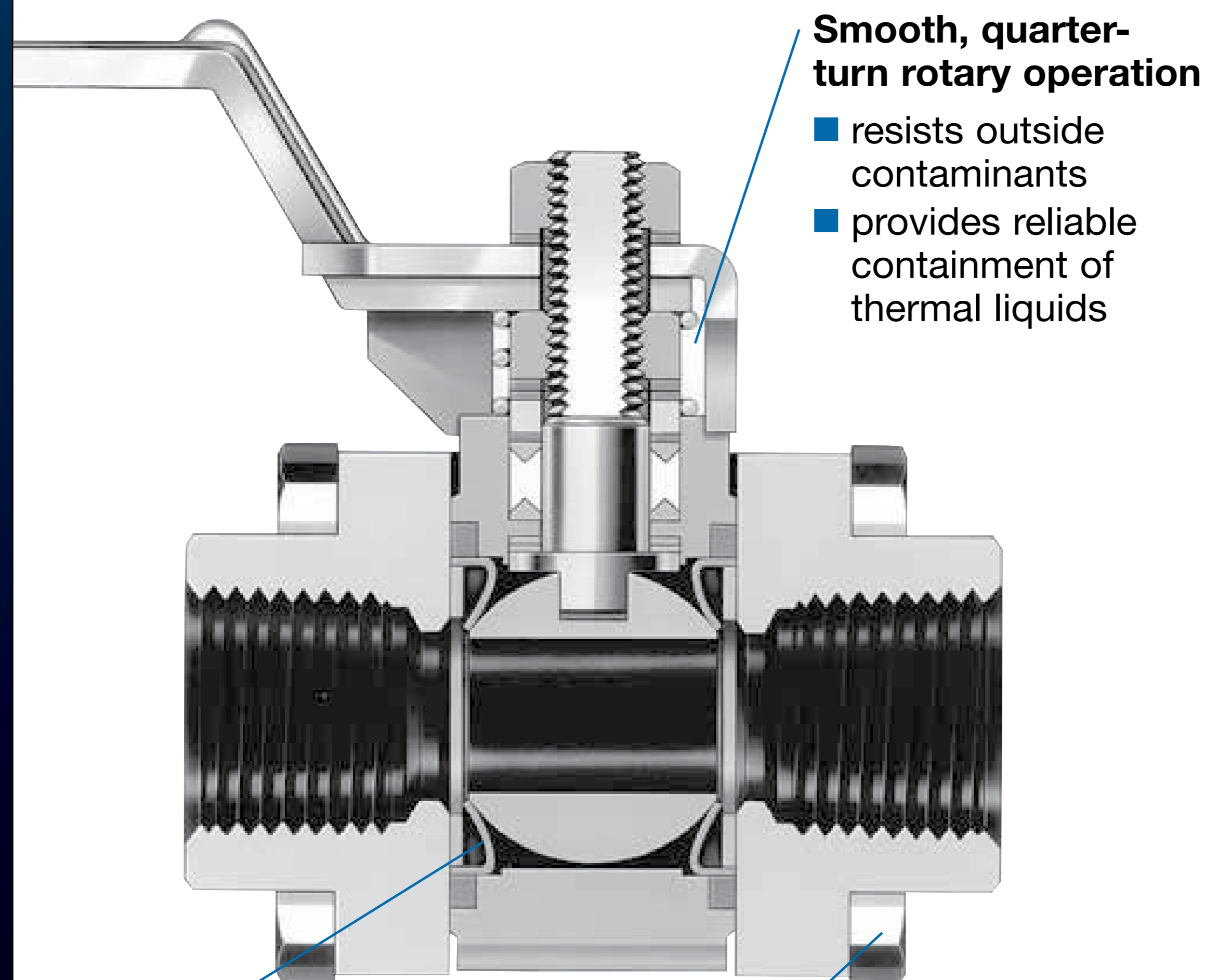

Smooth, quarter-turn rotary operation

- resists outside contaminants
- provides reliable containment of thermal liquids

Unique, spring-loaded metal seats

- provide positive leak-tight sealing at temperatures up to 850°F (454°C)
- work equally well in low- and high-pressure systems.

Encased 8-bolt construction

resists differential thermal expansion of body components during rapid temperature cycling

THERMAL SERVICE - T60M SERIES

Our thermal service ball valve, is designed for applications in which heat transfer liquids are used. With its unique, spring-like metal seat, this valve is designed to maintain a seal with a minimum seat load against the ball.

- Pressure rated up to **1000 psig (68.9 bar)**
- Temperature ratings **-65 to 850°F (-53 to 454°C)**
- 316 SS or carbon steel material with Grafoil packing and alloy X-750 seats
- **Resists contamination of the thermal liquid**
- **Intended for use with high-viscosity thermal fluids**
- Meets or exceeds FCI 70-2 Class VI for leak-tight shutoff
- Exceeds performance requirements of Fire Test Standard API 607, 6th edition

FIRE SERVICE - A60T SERIES

For applications that require a fire-rated valve, the A60T series meets the API standards as well as the stringent Swagelok standards for fire testing.

- Temperature ratings as low as **-40 to 400°F (-40 to 204°C)**
- Pressure rated up to **2200 psig (151 bar)**
- Meets API Standard 607, 6th edition Fire Test for Soft-Seater Quarter Turn Valves

For more information:

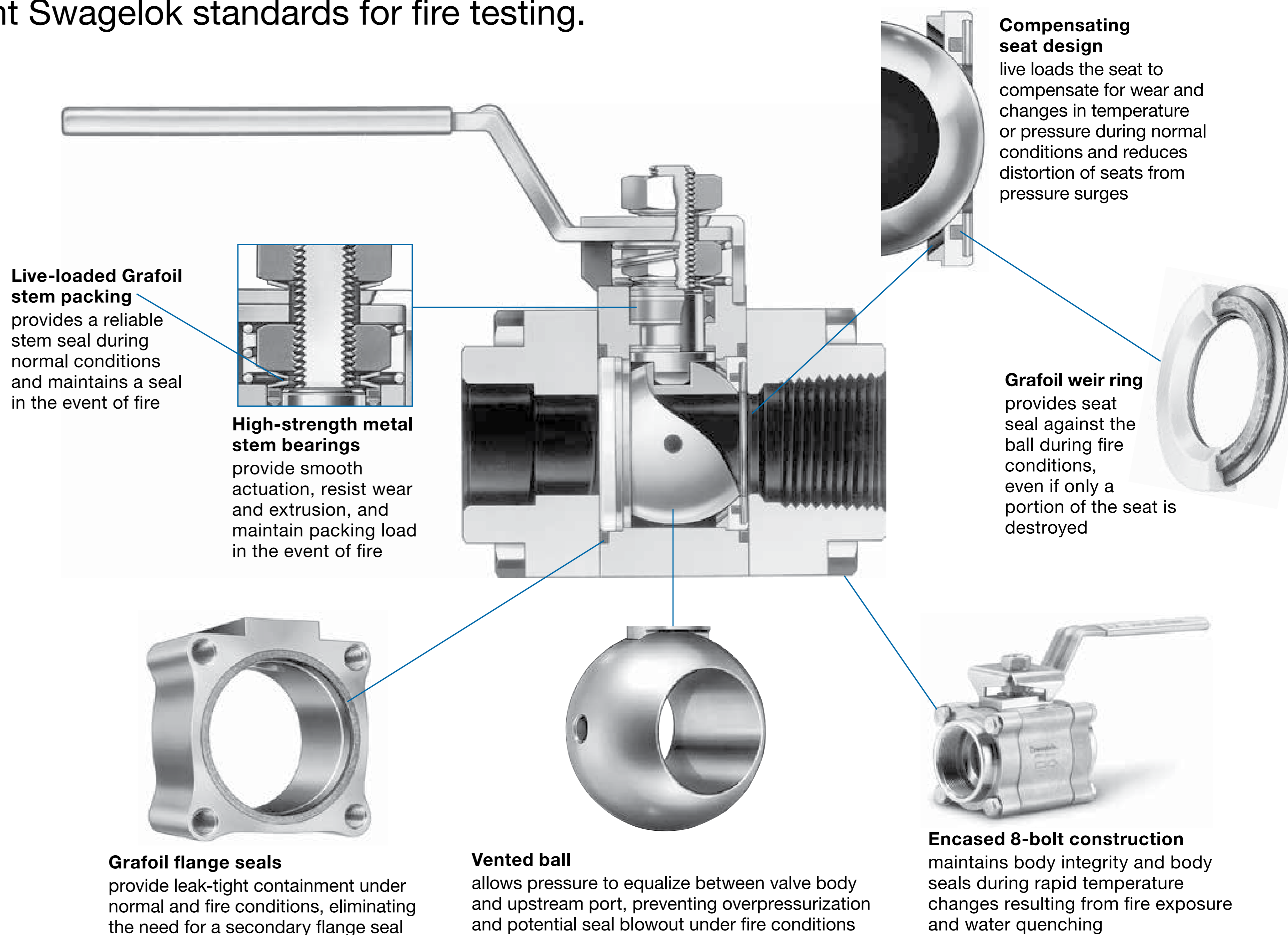



STEAM TRAP TEST ASSEMBLY - TVA SERIES

Designed for use with saturated steam systems, the Swagelok TVA series integrated test valve assembly consists of two 60 series ball valves and a universal mount in one integrated package.

- Service rating: **250 psig (17 bar) at 417°F (214°C)**
- Offers **fast, visual monitoring of steam trap performance**
- The upstream isolation valve allows for **quick, safe, and reliable maintenance of the steam trap**

FROM MANUAL OPERATION TO AUTOMATIC

Swagelok 60 series ball valves are compatible with the following actuators and accessories:

Pneumatic Actuators

- Rack and Pinion
- ISO 5211-Compliant

Electric Actuators

- AC or DC

Actuator Accessories

- Solenoid Valves
- Limit Switches
- Position Sensors



PNEUMATIC ACTUATORS

Swagelok rack and pinion pneumatic actuators are compact, lightweight, easily mountable, and can be operated with standard shop air.

- Standard pressure rating is 165 psig (11.3 bar)
- Standard temperature range is -20 to 200°F (-28 to 93°C)
- 90° and 180° actuation
- Spring-return and double-acting
- High temperature, Low temperature, and Nonfluorocarbon service actuators available
- Available for in-house or field assembly

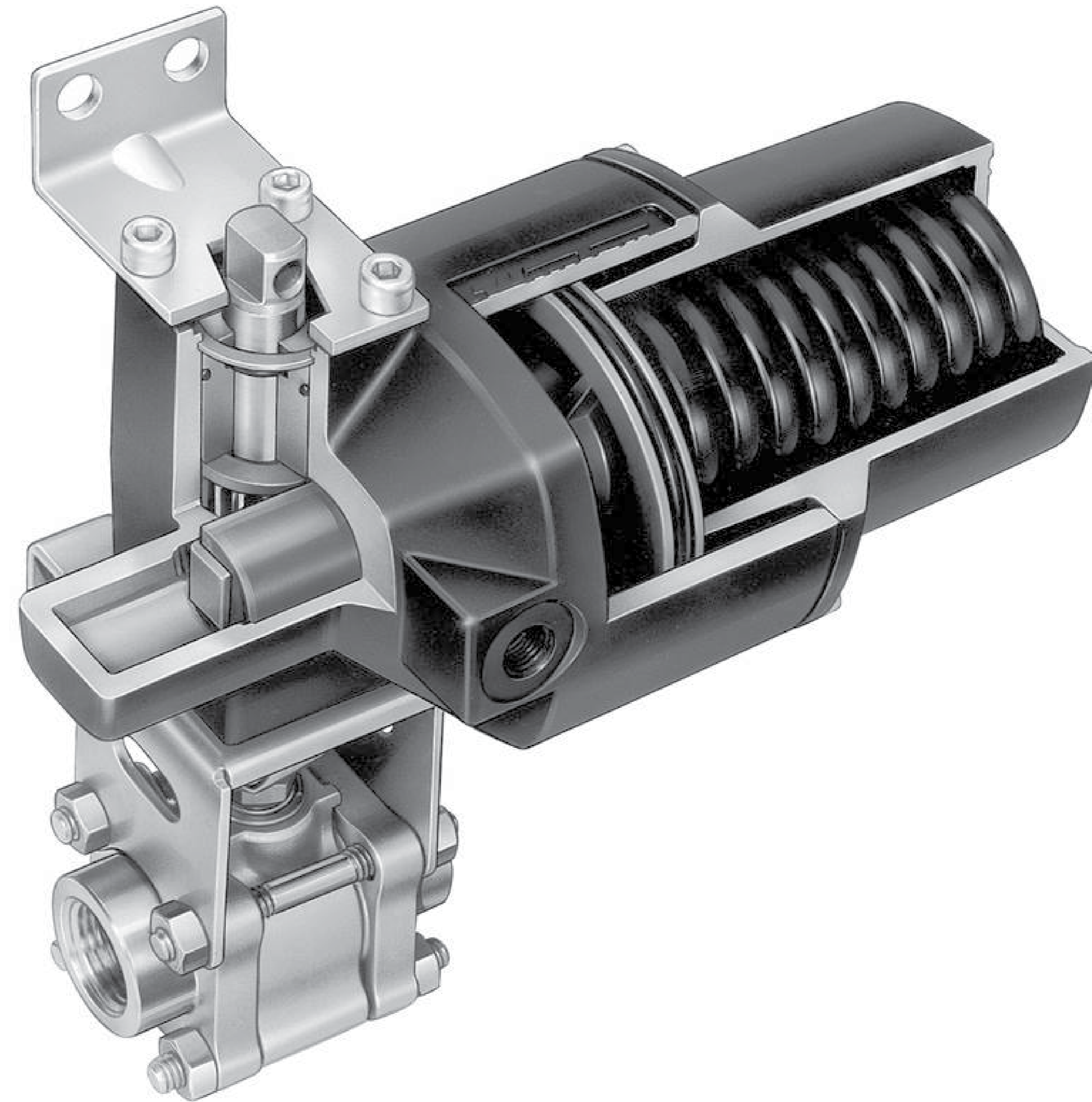

ISO 5211-COMPLIANT PNEUMATIC ACTUATORS

The **ISO-COMPLIANT PNEUMATIC ACTUATORS** are suitable for general applications.

- Maximum actuator pressure is 116 psig (8.0 bar)
- Standard temperature range is -40 to 176°F (-40 to 80°C)
- Spring-return and double-acting
- 90° and 180° actuation
- Available for in-house or field assembly

THE 60 SERIES BALL VALVE CAN ALSO BE MOUNTED TO ANY ISO-5211 COMPLIANT ACTUATORS.





ELECTRIC ACTUATORS

The 60 series is also available with an AC or DC electric actuator.

- 2 and 3-way operation
- Meet both NEMA 4X or IP66 specifications depending upon conduit selected
- Integral limit switches provide output signal of valve position
- Available for 62 and 63 series

ACTUATOR ACCESSORIES

Swagelok offers a range of accessories to enhance instrumentation and process ball valve performance and control.

- **Solenoid valves** - attach to the actuator to create an electropneumatically actuated assembly
- **Limit switches** - indicate actuator position by means of an electrical signal
- **Position sensors** - Provide visual status for a valve

For more information visit the:



CUSTOM OPTIONS FOR 60 SERIES BALL VALVES

- **Distribution Block Valve:** eliminate the need to fabricate assemblies from separate components
- **Double Block and Bleed Valve:** save space and avoid the bulk, weight, complexity, and potential leak points



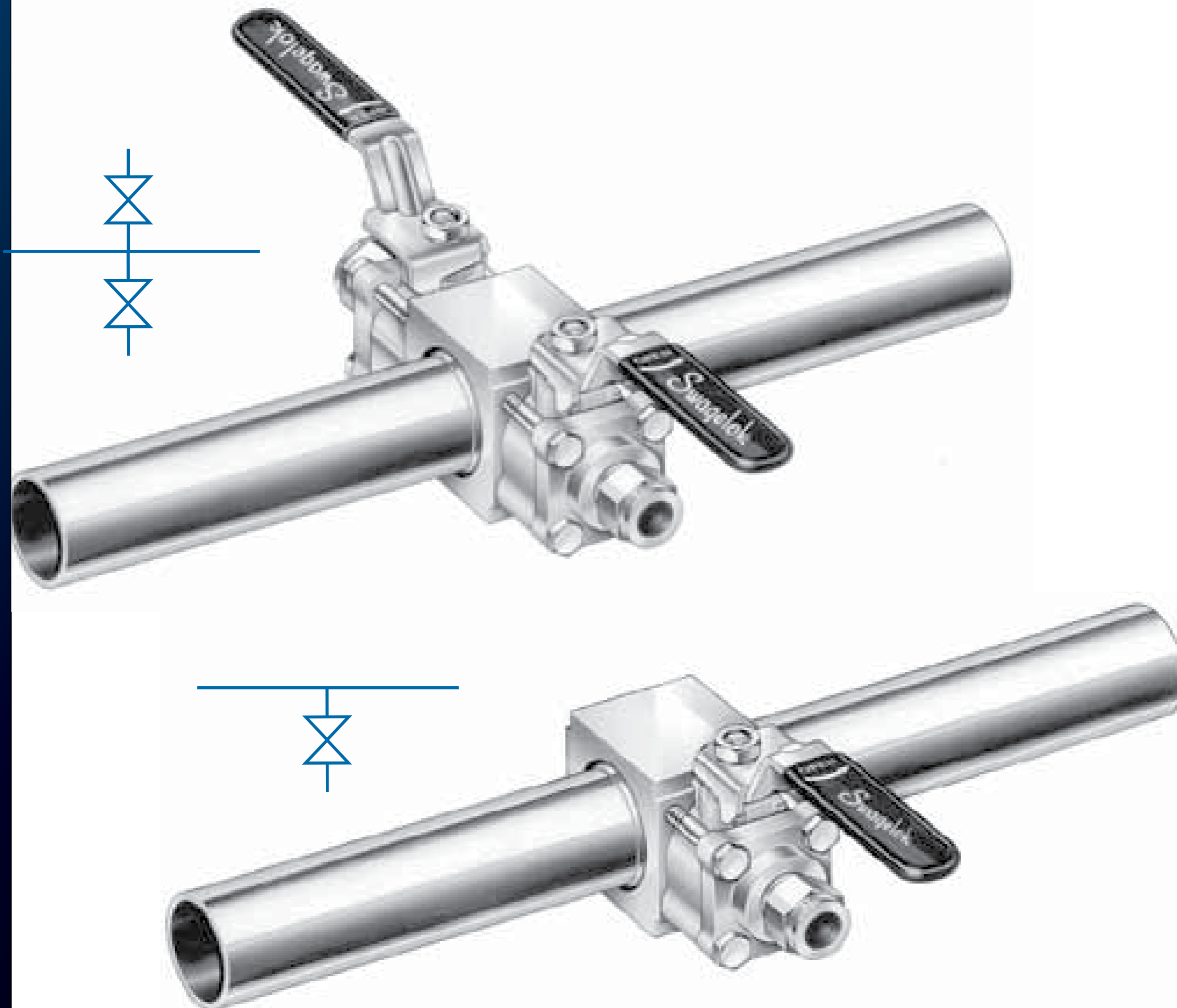

DISTRIBUTION BLOCK VALVES D60 SERIES

Eliminate the need to fabricate assemblies from separate components with Distribution Block Valves featuring:

Integrated Distribution Block Valves

- Stronger than brazed assemblies, enhancing system structural integrity
- Offer lower internal volume
- Provide flexibility for different system layouts

Main Line Tubing

- Available in a range of sizes to match commonly used headers
- Provides straight, unrestricted flow through block
- Can be welded directly to head without disassembling

Gaugeable Swagelok Tube Fitting Branch Connections

- Provide a leak-tight seal without system shutdown and prefabrication expenses associated with brazing
- Available in a range of sizes to match branch tubing

60 SERIES DOUBLE BLOCK AND BLEED VALVE

Save space and **avoid the bulk, weight, complexity, and potential leak points** of assemblies made up of individual components with the 60 series double block and bleed (DBB) valve.

The 60 series DBB valve **joins two 60 series ball valves to a modified center body containing a vent needle valve**. Plus it offers the positive sealing and high-flow capacity only ball valves can deliver.

- Working pressures up to **2200 psig** (151 bar)
- Temperatures from **-20 to 450°F (-28 to 232°C)**
(Reinforced PTFE seats)
- **316 stainless steel** construction
- **Factory-tested** with nitrogen to **1000 psig (69 bar)**
- **Standard vent needle valve** based on Swagelok 20V series design

INDEX

Designed for Reliability and Low Maintenance

60 Series Product Overview

- At a Glance _____
- End Connection Flexibility _____
- Handle Options _____
- Ease of Maintenance _____
- Options and Accessories _____

Performance and Design _____

- Traditional Valve Design _____
- Robust Seat Seal _____
- Reliable Stem Seal _____
- Chevron Packing vs. Conventional Packing _____
- Safety Features _____
- Swagelok Promise _____

Special Application Valves _____

- All Welded _____
- Chlorine Service _____
- Low Temperature Service _____
- Rapid Cycle _____
- Steam Service _____
- Thermal Service _____
- Fire Series _____
- Test Valve Assembly (TVA Series) _____

Automation Options _____

- Pneumatic Actuators _____
- ISO-5211 Compliant Actuators _____
- Electric Actuators _____
- Actuator Accessories _____

60 Series Customization _____

- Distribution Block Valve _____
- Double Block and Bleed _____

Other Resources

- Flexing Seat Design _____
- Swagelok Limited Lifetime Warranty _____



FLEXING SEAT DESIGN ENSURES LEAK-TIGHT SEAL

UNDER LOW PRESSURE

Under low pressure, seals are created by the coned-disc spring-loaded seats pushing against the ball. Pressure is not required to create a seal.

A uniform seal is created on both the upstream and downstream seats.

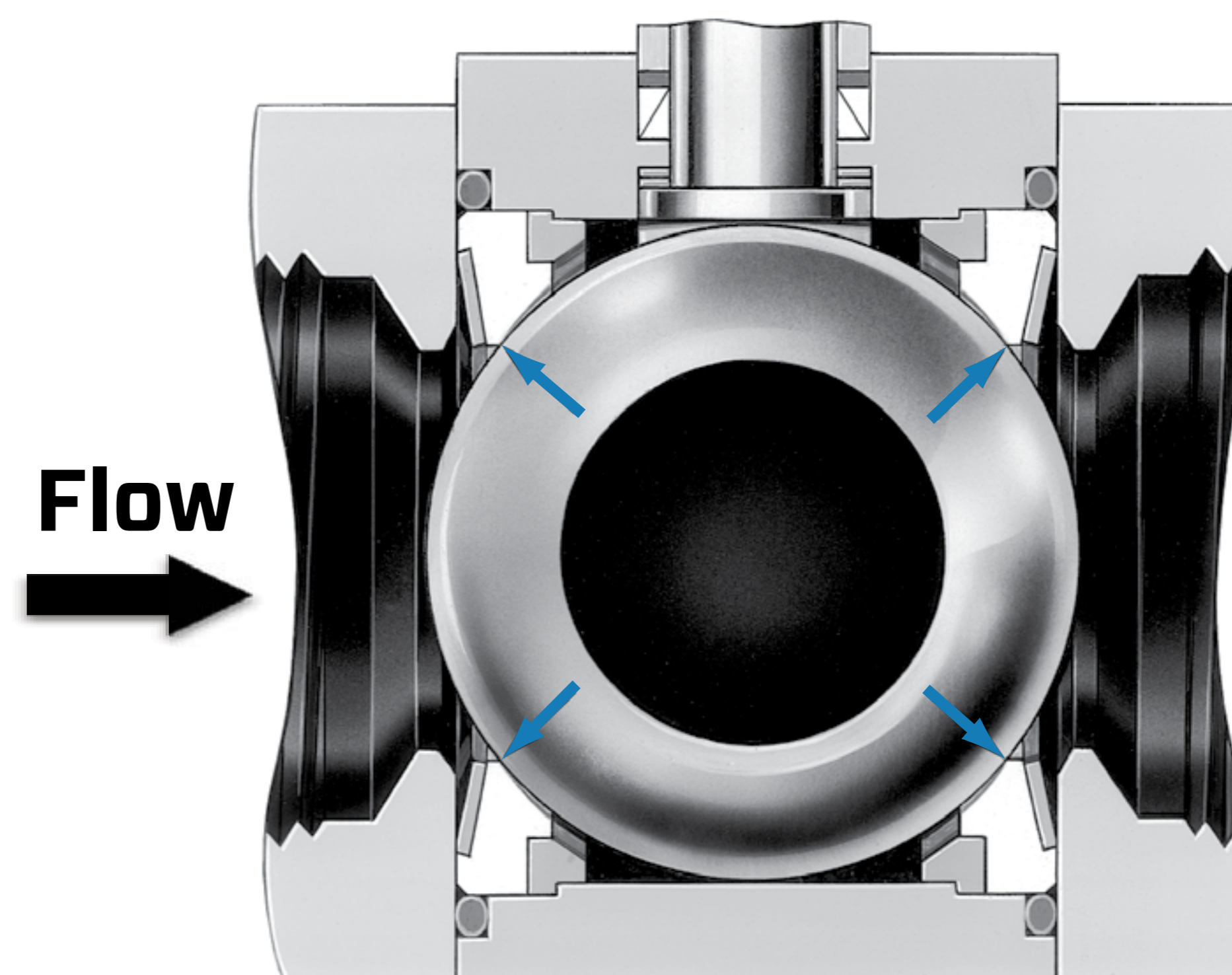
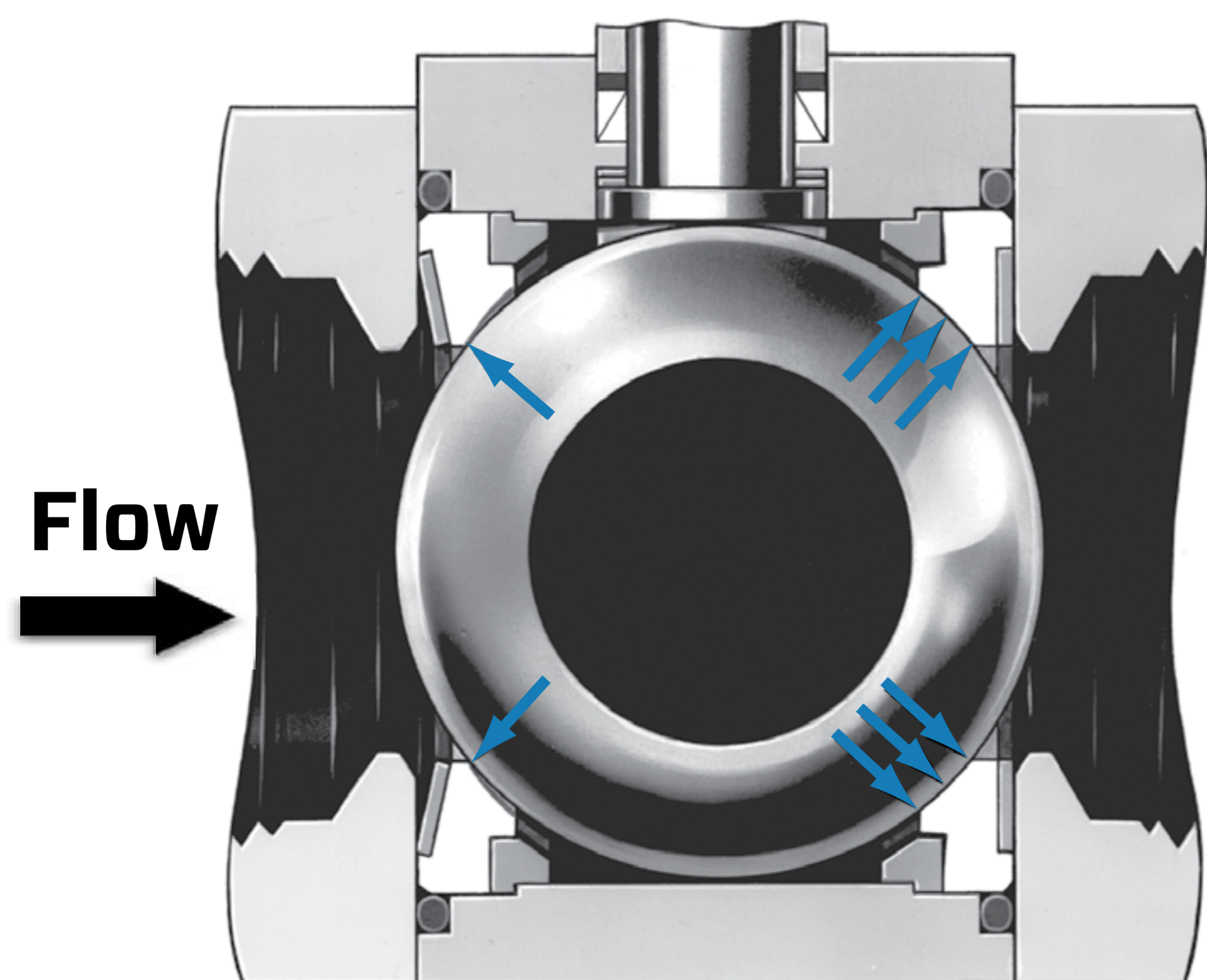

UNDER HIGH PRESSURE

Under high pressure, the ball is forced downstream, flexing the downstream seat and creating a seal. The upstream seat also flexes with the ball movement and maintains a seal.

As the seat is forced downstream due to pressure, the seat spring compresses thus reducing the force on the ball which reduces wear and leads to longer cycle life.

SWAGELOK LIMITED LIFETIME WARRANTY

The Swagelok Limited Lifetime Warranty

Swagelok and its authorized distributors hereby warrant to the purchaser of their Products that the non-electrical components shall be free from defects in material and workmanship for the life of the Products. All electrical components installed in or on the Product are warranted to be free from defects in material and workmanship for twelve months from the date of purchase.

The purchaser's remedies shall be limited to replacement and, in non-ground-vehicle applications, installation of any parts that fail through a defect in material or workmanship. Liability for installation is limited to reasonable costs that have been approved in advance and in writing by Swagelok.

All customer-specified components carry the applicable manufacturer's warranty. Warranty coverage hereunder only applies to Products purchased directly from either Swagelok or its authorized distributors and representatives. All other purchases are specifically excluded from any warranty coverage.

ALL OTHER REPRESENTATIONS, EXPRESS OR IMPLIED, WARRANTY, OR LIABILITY RELATING TO THE CONDITION OR USE OF THE PRODUCT ARE SPECIFICALLY DISAVOWED, AND IN NO EVENT SHALL SWAGELOK AND ITS AUTHORIZED DISTRIBUTORS BE LIABLE TO PURCHASER, OR ANY THIRD PARTY, FOR ANY DIRECT OR INDIRECT CONSEQUENTIAL OR INCIDENTAL DAMAGES.

The warranty for any firmware or software Products that contain programmable logic or a microprocessor is governed by a separate [Swagelok Embedded System End User License Agreement, MS-13-330](#) accessible from the www.swagelok.com website.

© 2017 Swagelok Calgary | Red Deer | Brooks | Medicine Hat

© 2017 Swagelok Company