

Medium- and High-Pressure Fittings, Tubing, Valves, and Accessories

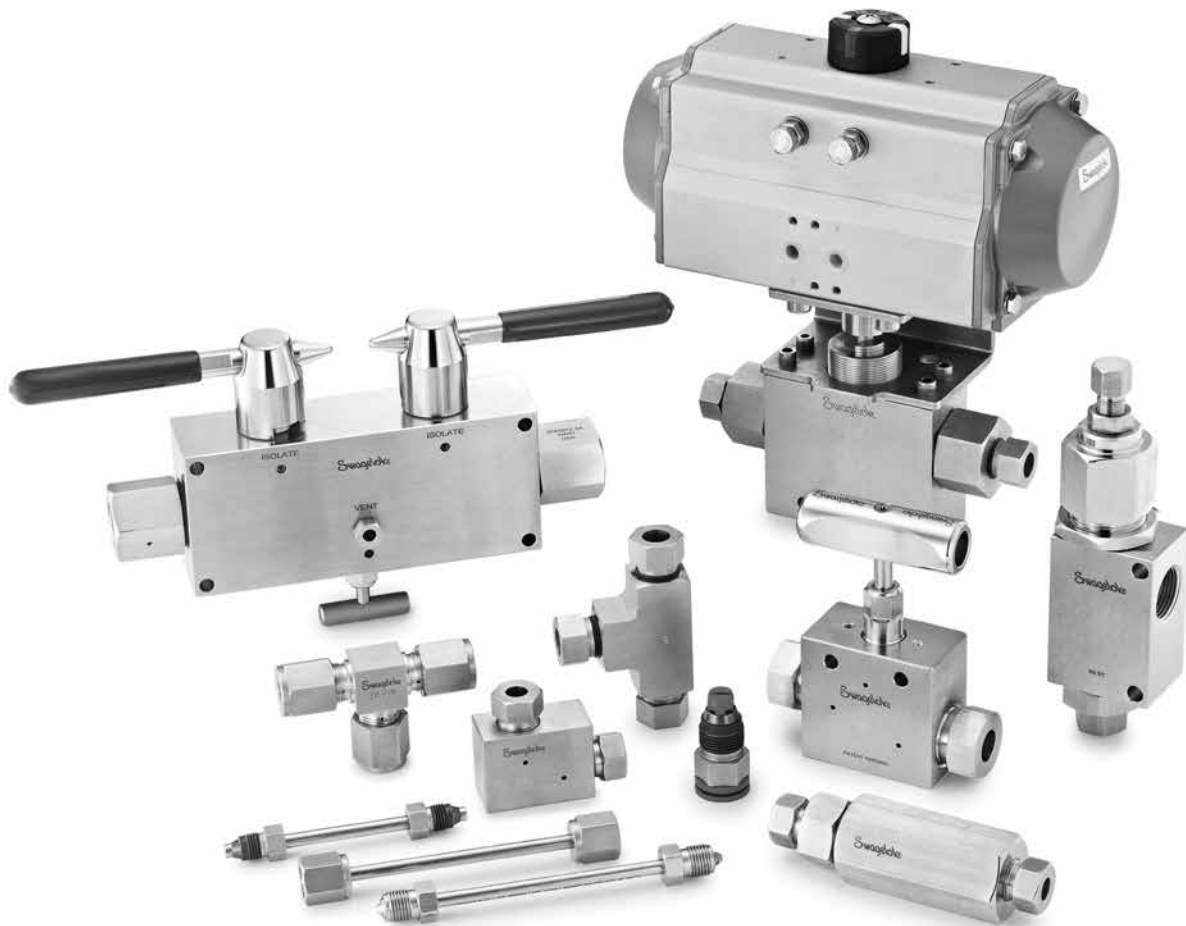

FK, FKB, IPT, and Sno-Trik® Series Products

- Rated up to 60 000 psig (4134 bar)
- End connections up to 1 1/2 in. and 12 mm
- NACE® MR0175/ISO15156 compliance available

Swagelok® Medium- and High-Pressure Fittings, Valves, and Tubing

Since 1947, Swagelok has designed, developed, and manufactured high-quality fluid system products to meet the evolving needs of global industries. Our focus is on understanding our customers' needs, finding timely solutions, and adding value with our products and services.

This catalog covers several of our products suitable for applications requiring higher pressures. In the following pages you will find technical and ordering information on medium and high-pressure products. These products have the following pressure characteristics:

Product Type	Maximum Working Pressure, psig (bar)	
	Medium Pressure	High Pressure
Ball Valves	Up to 20 000 (1378)	
Check Valves		Up to 60 000 (4134)
Cone & Thread Fittings, Adapters, and Couplings		Up to 60 000 (4134)
Double Block & Bleed Valves		
Medium Pressure Gaugeable Tube Fittings		
Needle Valves		Up to 60 000 (4134)
Relief Valves		
Tubing		Up to 60 000 (4134)

Applications

Medium- and high-pressure fittings, valves, and components are designed to meet requirements of demanding applications such as the following:

- Alternative fuel industry infrastructure
- Process control
- Instrumentation
- Chemical sampling
- Test stands
- Waterjet cutting/blasting
- Oil and gas
 - Wellhead control panels
 - Hydraulic control panels
 - Grease injector units
 - Blowout preventers
 - Chemical injection skids

Product Ratings

Swagelok Company rates products based on the principles of two ASME standards:

- ASME B31.3, Process Piping (Base Code)
- ASME B31.3, Process Piping, Chapter IX High Pressure Piping (Chapter IX)

As such, some products reference two pressure ratings for the same product. To ensure safe product selection, it is important for the system designer and user to understand how each standard applies to the application when selecting a product.

Compatibility of Cone and Thread Fittings

Swagelok IPT series medium- and high-pressure cone and thread fittings may be assembled with cone and thread fittings and tube end assemblies from other manufacturers who follow the dimensions referenced in Table 1, IPT Series Cone and Thread Fitting Dimensions, on page 1069.

Important: The above statement applies *only* to Swagelok IPT series medium- and high-pressure cone and thread fittings.

API-6A, Specification for Wellhead and Christmas Tree Equipment, defines the dimensions for the 9/16 inch high-pressure cone and thread fitting. Swagelok Company complies with the mechanical sealing dimensions called out in this specification. No other sizes or styles of cone and thread fittings or tubing are referenced in API-6A.

Contents

Fitting Products



FK Series

- **Medium-Pressure Gaugeable Tube Fittings and Adapter Fittings** 1049

IPT Series

- **Cone and Thread Fittings** 1067
 - **Safety Heads and Line Filters** 1071
- **Adapters and Couplings** 1075
- **Coning and Threading Tooling** 1089
- **Medium-Pressure Pipe Fittings** 1090
 - **Safety Heads and Line Filters** 1094

Sno-Trik Series

- **High-Pressure Cone and Ferrule Fittings** 1096
- **Custom Manifolds** 1104

Tubing Products



FK Series

- **Medium-Pressure Tubing** 1105

IPT Series

- **Cone and Thread Tubing and Tube Nipples** 1108

Sno-Trik Series

- **High-Pressure Tubing and Tube Nipples** 1110

Valve Products



Ball Valves

- **Medium-Pressure Trunnion-Style Ball Valves—FKB Series** 1112
- **Medium-Pressure Trunnion-Style Ball Valves—IPT Series** 1121
- **Subsea Service Ball Valves—IPT Series** 1127

Needle Valves

- **Needle Valves—IPT Series** 1131
- **High-Pressure Needle Valves—Sno-Trik Series** 1149

Block and Bleed Valves

- **Block and Bleed Valves—IPT Series** 1154

Check Valves

- **Check Valves—IPT Series** 1160

Relief Valves

- **Proportional Relief Valves—IPT Series** 1167

Swagelok Medium-Pressure, Gaugeable Tube Fittings and Adapter Fittings—FK Series

For Pressures up to 20 000 psig (1378 bar)



- 316 stainless steel construction
- Temperatures up to 1000°F (537°C)
- Working pressure up to 20 000 psig (1378 bar)
- Size range—1/4 to 3/4 in. and 6 to 12 mm

Contents

Features, 1050

Materials of Construction, 1050

Pressure Ratings, 1051

Cleaning and Packaging, 1053

Gaugeability, 1053

Ordering Information and Dimensions, 1053

Straight Fittings

Unions, 1053



Male Connectors, 1054



Female Connectors, 1055



Medium-Pressure Cone and Thread Adapters, 1056



Reducers, 1057



Port Connectors, 1057



Caps and Plugs, 1057



90° Elbows

Unions, 1058



Male, 1058



Tees

Unions, 1059



Male, 1059

Crosses

Unions, 1060



Tube Adapters

Male, 1060



Installation Instructions

- Medium-Pressure Tube Fitting Assembly, 1061
- Connections Preswaged with the MHSU, 1062
- Caps and Plugs, 1062
- Port Connectors Installation, 1062
- Tube Adapters and Reducers Installation, 1062
- Preswaging Tool, 1063
- Medium-Pressure Tube Fitting Reassembly, 1064

Replacement Parts

- Nut and Ferrules Cartridge, 1064

Tools and Accessories

- Preswaging Tool, 1065
- Depth Marking Tool, 1065
- Multihead Hydraulic Swaging Unit, 1065
- Medium-Pressure Gap Inspection Gauge, 1066

Swagelok Medium-Pressure Tube Fittings—FK Series

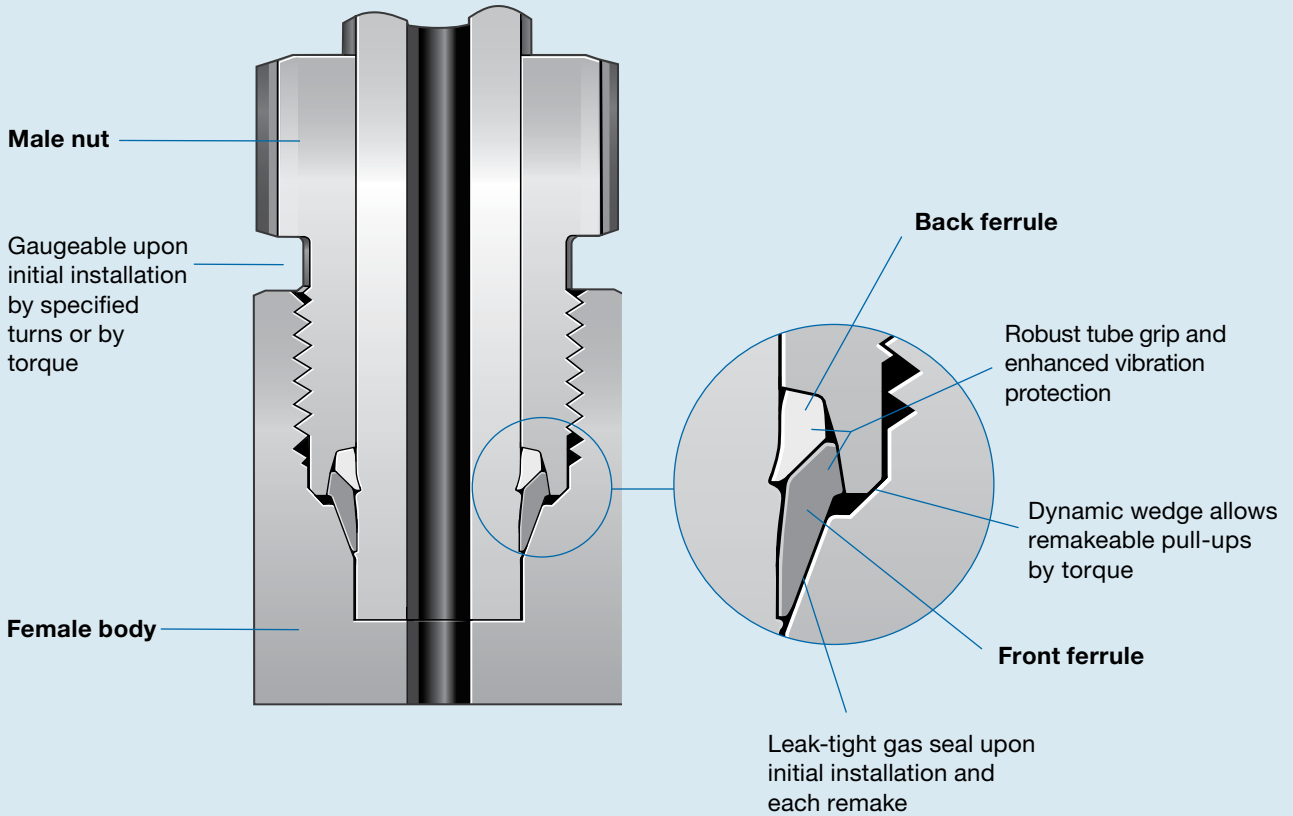

Features

The simple two-piece design of the Swagelok medium-pressure tube fittings and adapters consists of a female fitting body and preassembled cartridge containing the male nut and color-coded front and back ferrules on a disposable plastic arbor. The preassembled cartridge ensures installers correct ferrule orientation, visual confirmation of ferrule presence, and proper installation into the female body. Components are released only after the nut is threaded finger-tight on the fitting body.

The Swagelok medium-pressure tube fitting offers a leak-tight gas seal and vibration resistance in applications up to 20 000 psig (1378 bar).

Additional features of this novel tube fitting technology include:

- Patented low-temperature case hardening processing of the ferrules and nut, plus the specially designed ferrule geometry, promotes a patented hinging-colleting™ action
- Easy installation, by specified turns or torque
- Simple two-piece construction, body and cartridge
- Leak-tight performance on a variety of tubing types and materials
- Strain-hardened stainless steel bodies offer lightweight, space-saving designs
- Extensive Swagelok product test reports and third-party test reports

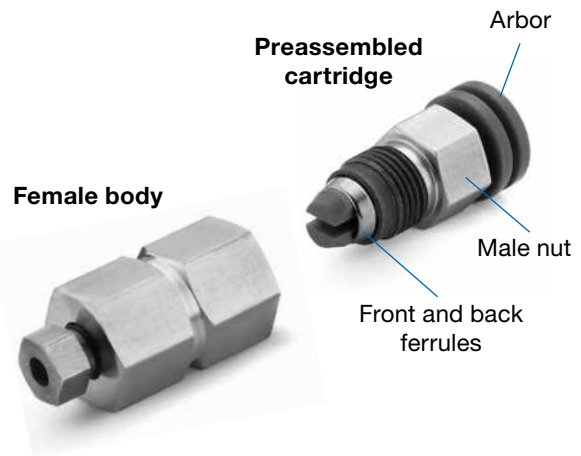

Materials of Construction

Component	Material/ASTM Specification
<i>Body</i>	316 SS/A276, A479
<i>Front ferrule</i>	316 SS/A276
Nut ^①	316 SS/A276, A479
Back ferrule	316 SS/A276

Wetted components listed in *italics*.

① Molybdenum disulfide-based lubricant.

Pressure Ratings

Pressure ratings are dependent on the end connection or system component with the lowest pressure rating. Ratings for the end connections used in this catalog are identified below.

Swagelok Medium-Pressure Tube Fittings—FK Series

Swagelok medium-pressure ends are rated to the working pressure of the tubing as listed below. Calculations are based on maximum outside diameter and minimum wall thickness.

Heavy-Wall Annealed 316 Stainless Steel Tubing^①

Allowable working pressures are calculated from an S value of 20 000 psi (137.8 MPa) for ASTM A269 tubing at -20 to 100°F (-28 to 37°C), as listed in ASME B31.3. See **Elevated Temperature Factors**, page 1052, for tubing use above 100°F (37°C).

Tube OD in.	Wall Thickness in.	Working Pressure psig (bar)
1/4	0.095	15 000 (1034)
3/8	0.134	15 000 (1034) ^②
1/2	0.188	15 000 (1034)

Tube OD mm	Wall Thickness mm	Working Pressure bar (psig)
6	2.2	1034 (15 000) ^②
10	3.5	1034 (15 000) ^②
12	4.5	1034 (15 000)

- ① No allowance is made for corrosion, erosion, or elevated temperatures.
- ② Pressure rating based on special wall thickness tolerance ± 10 % for heavy-wall annealed 316 stainless steel tubing.

Suggested Ordering Information

Fully annealed, high-quality type 316 stainless steel tubing ASTM A269 or A213, or equivalent. Hardness not to exceed 90 HRB. Tubing to be free of scratches, suitable for bending and flaring.

Cold-Drawn 1/8-Hard 316 Stainless Steel Tubing^①

Allowable working pressures are calculated from an S value of 35 000 psi (241 MPa) at -20 to 100°F (-28 to 37°C) for ASME B31.3 and an S value of 50 000 psi (344 MPa) for ASME B31.3 Chapter XI. See **Elevated Temperature Factors**, page 1052, for tubing use above 100°F (37°C).

Tube OD in.	Wall Thickness in.	Working Pressure psig (bar)	
		ASME B31.3 ^②	Chapter IX ^③
1/4	0.065	15 000 (1034)	20 000 (1378)
3/8	0.083		
1/2	0.109		
3/4	0.165		

Tube OD mm	Wall Thickness mm	Working Pressure bar (psig)	
		ASME B31.3 ^②	Chapter IX ^③
6	1.5	1034 (15 000)	1378 (20 000)
10	2.2		
12	2.8		

- ① No allowance is made for corrosion, erosion, or elevated temperatures.
- ② Working pressure determined based on ASME B31.3 Process Piping.
- ③ Working pressure determined based on ASME B31.3 Process Piping, Chapter IX High Pressure Piping.

Suggested Ordering Information

Cold-drawn 1/8-hard high-quality type 316 stainless steel tubing. OD tolerance ± 0.005 in. / ± 0.127 mm and wall thickness tolerance of ± 10 %. Minimum tensile strength 105 000 psi (723.5 MPa), yield strength 75 000 psi (516.8 MPa), minimum elongation 20 %, hardness not to exceed 26 HRC. Tubing to be free of scratches, suitable for bending and flaring.

Fractional Cone and Thread (C&T) Tubing^①

Allowable working pressures are calculated from an S value of 35 000 psi (241 MPa) at -20 to 100°F (-28 to 37°C) for ASME B31.3 and an S value of 50 000 psi (344 MPa) for ASME B31.3 Chapter XI. See **Elevated Temperature Factors**, page 1052, for tubing use above 100°F (37°C).

Cone and thread tubing is 1/8-hard 316 seamless stainless steel tubing that has a nominal outside diameter to assist in coning and threading operations when the tube is used with fittings.

Nominal Tube OD in.	Nominal Tube ID in. (mm)	Working Pressure psig (bar)	
		ASME B31.3 ^②	Chapter IX ^③
9/16	0.359 (9.12)	10 000 (689)	—
	0.312 (7.92)	15 000 (1034)	20 000 (1378)
3/4	0.438 (11.1)	12 500 (861)	—

- ① No allowance is made for corrosion, erosion, or elevated temperatures.
- ② Working pressure determined based on ASME B31.3 Process Piping.
- ③ Working pressure determined based on ASME B31.3 Process Piping, Chapter IX High Pressure Piping.

Pressure Ratings

Alloy 2507 Super Duplex Tubing^①

Allowable working pressures are calculated from an S value of 38 700 psi (266.6 MPa) for ASME B31.3 and an S value of 53 300 psi (367 MPa) for ASME B31.3 Chapter IX. Pressure ratings are for metal temperatures from -20 to 100°F (-28 to 37°C). See **Elevated Temperature Factors**, page 1052, for tubing use above 100°F (37°C).

Tube OD in.	Wall Thickness in. ^②	Working Pressure, psig (bar)	
		ASME B31.3 ^③	Chapter IX ^④
1/4	0.035	10 000 (689)	—
	0.049	15 000 (1034) ^⑤	20 000 (1378)
3/8	0.049	10 100 (695) ^⑤	—
	0.065	12 700 (875)	18 300 (1260)
	0.083	15 000 (1034)	20 000 (1378)
1/2	0.065	10 100 (695) ^⑤	—
	0.083	12 900 (888)	18 600 (1281)
	0.095	15 000 (1034)	20 000 (1378)
3/4	0.095	10 000 (689) ^⑤	—
	0.109	11 100 (764)	—
	0.120	12 400 (854)	17 900 (1233)
	0.134	15 000 (1034) ^⑤	20 000 (1378)

- ① No allowance is made for corrosion, erosion, or elevated temperatures.
 ② For gas service, select a tube wall thickness *outside* of the shaded areas.
 ③ Working pressure determined based on ASME B31.3 Process Piping.
 ④ Working pressure determined based on ASME B31.3 Process Piping, Chapter IX High Pressure Piping.
 ⑤ Pressure rating based on special wall thickness tolerance for Swagelok Alloy 2507 tubing.

Elevated Temperature Factors

To determine allowable working pressure at elevated temperatures, multiply allowable working pressures from the tables above by a factor shown in the table below.

Temperature		Heavy-Wall Annealed 316 SS Tubing	Cold-Drawn 1/8 Hard 316 SS Tubing	Alloy 2507 Super Duplex Tubing
°F	°C			
200	93	1.00	1.00	0.90
300	148	1.00	1.00	0.85
400	204	0.96	0.93	0.82
600	315	0.85	0.93	0.81 ^①
800	426	0.79	0.92	—
1000	537	0.76	0.84	—

- ① Alloy 2507 Super Duplex Tubing has a maximum temperature rating of 482°F (250°C).

Example: heavy-wall annealed 316 stainless steel tubing
 1/4 in. OD × 0.095 in. wall at 1000°F (537°C):

- The allowable working pressure at -20 to 100°F (-28 to 37°C) is 15 000 psig (1034 bar).
- The elevated temperature factor for 1000°F (537°C) is 0.76:
 $15\,000\text{ psig (1034 bar)} \times 0.76 = 11\,400\text{ psig (785 bar)}$

The allowable working pressure for heavy-wall annealed 316 stainless steel tubing 1/4 in. OD × 0.095 in. wall at 1000°F (537°C) is 11 400 psig (785 bar).

Suggested Ordering Information

High-quality, fully annealed Alloy 2507 super duplex tubing, ASTM A789 or equivalent. Hardness not to exceed 32 HRC. Tubing to be free of scratches, suitable for bending and flaring.

Heavy-Duty SAE/MS End Connections

Heavy-duty SAE/MS end connections listed in this section (1/4 and 3/8 in. sizes) are rated to 63 MPa (9137 psig), in accordance with SAE J1926/2.

NPT End Connections^①

Male and Female NPT Size in.	Pressure Rating ^② psig (bar)
1/16, 1/8, 1/4, 3/8, 1/2	15 000 (1034)
3/4, 1	10 000 (689)

- ① No allowance is made for corrosion, erosion, or elevated temperatures.
 ② Working pressure determined based on ASME B31.3 Process Piping, Chapter IX High Pressure Piping.

Cleaning and Packaging

All medium-pressure fittings are cleaned in accordance with Swagelok *Standard Cleaning and Packaging (SC-10)* (MS-06-62), page 1174.

All medium-pressure fittings are provided with a preassembled cartridge containing the male nut and front and back ferrules on a disposable plastic arbor, one cartridge per medium-pressure end connection.

Gaugeability

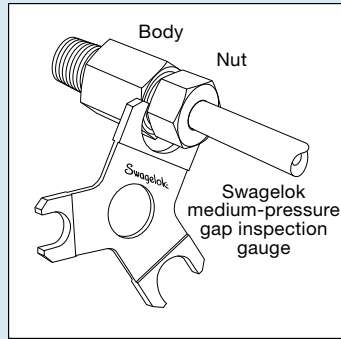

On initial installation, the **Swagelok medium-pressure gap inspection gauge** assures the installer or inspector that a fitting has been sufficiently tightened.

Position the Swagelok medium-pressure gap inspection gauge next to the gap between the nut and body.

- If the gauge will not enter the gap, the fitting is sufficiently tightened.
- If the gauge will enter the gap, additional tightening is required.

Ordering Information and Dimensions

Dimensions are for reference only and are subject to change. Dimensions shown with Swagelok nuts finger-tight.

Additional configurations and adapters are available on request. Contact your authorized Swagelok representative.

The pressure ratings of configurations with SAE and NPT end connections are limited to the rating of the SAE or NPT end connection; see page 1052.

Straight Fittings

Unions

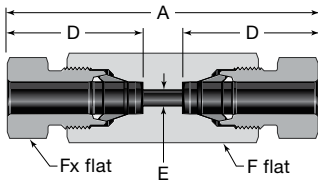

Union

Tube OD	Ordering Number	Dimensions				
		A	D	E	F	Fx
Dimensions, in.						
1/4	SS-4FK0-6	2.25	1.08	0.13	5/8	9/16
3/8	SS-6FK0-6	2.81	1.34	0.21	3/4	11/16
1/2	SS-8FK0-6	3.36	1.59	0.38	1	7/8
9/16	SS-9FK0-6	3.69	1.75	0.41	1 1/8	1 1/16
3/4	SS-12FK0-6	4.84	2.29	0.56	1 1/2	1 3/8
Dimensions, mm						
6	SS-6MFK0-6	57.2	27.4	3.2	16	15
10	SS-10MFK0-6	85.3	40.4	5.6	24	22
12	SS-12MFK0-6	85.3	40.4	6.4	27	22

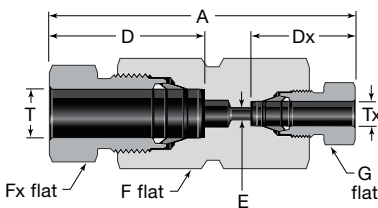

Reducing Union

Tube OD		Ordering Number	Dimensions						
T	Tx		A	D	Dx	E	F	Fx	G
Dimensions, in.									
3/8	1/4	SS-6FK0-6-4	2.64	1.34	1.08	0.13	3/4	11/16	9/16
1/2	1/4	SS-8FK0-6-4	2.90	1.59	1.34	0.13	1	7/8	9/16
	3/8	SS-8FK0-6-6	3.19	1.59	1.34	0.21	1	7/8	11/16
9/16	1/2	SS-9FK0-6-8	3.63	1.75	1.59	0.38	1 1/8	1 1/16	7/8
3/4	1/2	SS-12FK0-6-8	4.26	2.29	1.59	0.38	1 1/2	1 3/8	7/8
Dimensions, mm									
10	6	SS-10MFK0-6-6M	74.0	40.4	27.4	3.2	24	22	15
12	6	SS-12MFK0-6-6M	74.0	40.4	27.4	3.2	27	22	15
	10	SS-12MFK0-6-10M	86.4	40.4	40.4	5.6	27	22	22

Straight Fittings

Unions

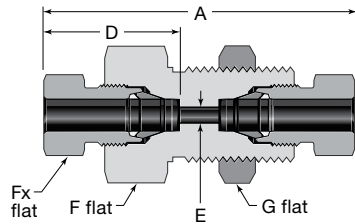

Bulkhead Union

Tube OD	Ordering Number	Dimensions							Panel Hole Size	Maximum Panel Thickness
		A	D	E	F	Fx	G			
Dimensions, in.										
1/4	SS-4FK0-61	2.25	1.08	0.13	15/16	9/16	15/16	49/64	0.50	
3/8	SS-6FK0-61	2.81	1.34	0.21	1 1/16	11/16	1 1/16	57/64	0.66	
1/2	SS-8FK0-61	3.38	1.59	0.38	1 5/16	7/8	1 5/16	1 9/64	0.75	
9/16	SS-9FK0-61	3.69	1.75	0.41	1 5/8	1 1/16	1 5/8	1 21/64	0.75	
3/4	SS-12FK0-61	4.84	2.29	0.56	1 7/8	1 3/8	1 7/8	1 41/64	1.00	
Dimensions, mm										
6	SS-6MFK0-61	57.2	27.4	3.2	24	15	24	19.5	12.7	
10	SS-10MFK0-61	85.8	40.4	5.6	30	22	30	26.0	20.0	
12	SS-12MFK0-61	85.8	40.4	6.4	35	22	35	29.0	19.0	

Male Connectors

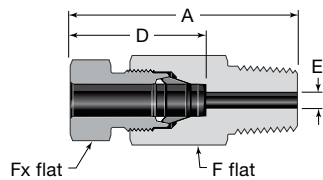

NPT

Tube OD	NPT Size in.	Ordering Number	Dimensions				
			A	D	E	F	Fx
Dimensions, in.							
1/4	1/8	SS-4FK0-1-2	1.60	1.08	0.13	5/8	9/16
	1/4	SS-4FK0-1-4	1.74	1.08	0.25	5/8	9/16
	3/8	SS-4FK0-1-6	1.74	1.08	0.13	11/16	9/16
	1/2	SS-4FK0-1-8	1.93	1.08	0.13	7/8	9/16
3/8	1/4	SS-6FK0-1-4	2.03	1.34	0.21	3/4	11/16
	3/8	SS-6FK0-1-6	2.03	1.34	0.21	3/4	11/16
	1/2	SS-6FK0-1-8	2.22	1.34	0.21	7/8	11/16
1/2	1/4	SS-8FK0-1-4	2.33	1.59	0.25	1	7/8
	3/8	SS-8FK0-1-6	2.33	1.59	0.33	1	7/8
	1/2	SS-8FK0-1-8	2.52	1.59	0.38	1	7/8
	3/4	SS-8FK0-1-12	2.52	1.59	0.38	1 1/16	7/8
9/16	1/4	SS-9FK0-1-4	2.64	1.75	0.25	1 1/8	1 1/16
	1/2	SS-9FK0-1-8	2.68	1.75	0.41	1 1/8	1 1/16
3/4	1/2	SS-12FK0-1-8	3.37	2.29	0.41	1 1/2	1 3/8
	3/4	SS-12FK0-1-12	3.37	2.29	0.56	1 1/2	1 3/8
	1	SS-12FK0-1-16	3.46	2.29	0.56	1 1/2	1 3/8
Dimensions, mm							
6	1/4	SS-6MFK0-1-4	44.1	27.4	3.2	16	15
10	1/4	SS-10MFK0-1-4	59.1	40.4	5.6	24	22
12	1/4	SS-12MFK0-1-4	59.1	40.4	6.4	27	22

Straight Fittings

Male Connectors

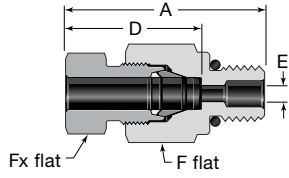

Heavy-Duty Male SAE/MS (STH)

Tube OD	SAE/MS Thread Size	Ordering Number	Dimensions				
			A	D	E	F	Fx
Dimensions, in.							
1/4	7/16-20	SS-4FK0-1-4STH	1.61	1.08	0.13	5/8	9/16
	9/16-18	SS-4FK0-1-6STH	1.65	1.08	0.13	3/4	9/16
3/8	7/16-20	SS-6FK0-1-4STH	1.91	1.34	0.20	3/4	11/16
	9/16-18	SS-6FK0-1-6STH	1.95	1.34	0.21	3/4	11/16
1/2	7/16-20	SS-8FK0-1-4STH	2.29	1.59	0.20	1	7/8
	9/16-18	SS-8FK0-1-6STH	2.29	1.59	0.38	1	7/8
Dimensions, mm							
6	7/16-20	SS-6MFK0-1-4STH	40.8	27.4	3.2	16	15
	9/16-18	SS-6MFK0-1-6STH	41.8	27.4	3.2	19	15
10	7/16-20	SS-10MFK0-1-4STH	58.2	40.4	5.2	24	22
	9/16-18	SS-10MFK0-1-6STH	58.2	40.4	5.6	24	22
12	7/16-20	SS-12MFK0-1-4STH	58.2	40.4	5.2	27	22
	9/16-18	SS-12MFK0-1-6STH	58.2	40.4	6.4	27	22

Female Connectors

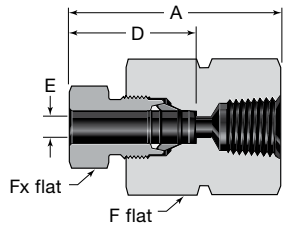

NPT

Tube OD in.	NPT Size in.	Ordering Number	Dimensions, in.				
			A	D	E	F	Fx
1/4	1/4	SS-4FK0-7-4	1.85	1.08	0.13	1	9/16
3/8	1/4	SS-6FK0-7-4	2.10	1.34	0.21	1	11/16
1/2	1/4	SS-8FK0-7-4	2.42	1.59	0.38	1	7/8
	1/2	SS-8FK0-7-8	2.66	1.59	0.38	1 1/2	7/8
3/4	1/2	SS-12FK0-7-8	3.40	2.29	0.56	1 1/2	1 3/8

Straight Fittings

Medium-Pressure Cone and Thread Adapters

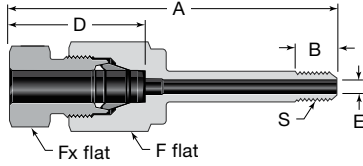

Tube Nipple

Tube OD	C&T Tube Size in.	Ordering Number	S Thread Size	Dimensions					
				A	B	D	E	F	Fx
Dimensions, in.									
1/4	1/4	SS-4FK0-1-4CW	1/4-28 LH	2.70	0.31	1.08	0.11	5/8	9/16
3/8	3/8	SS-6FK0-1-6CW	3/8-24 LH	3.22	0.39	1.34	0.21	3/4	11/16
1/2	9/16	SS-8FK0-1-9CW	9/16-18 LH	4.04	0.47	1.59	0.28	1	7/8
3/4	9/16	SS-12FK0-1-9CW	9/16-18 LH	4.83	0.47	2.29	0.31	1 1/2	1 3/8
Dimensions, mm									
6	1/4	SS-6MFK0-1-4CW	1/4-28 LH	68.5	7.9	27.4	2.7	16	15
10	3/8	SS-10MFK0-1-6CW	3/8-24 LH	90.3	9.9	40.4	5.3	24	22
12	9/16	SS-12MFK0-1-9CW	9/16-18 LH	103	11.9	40.4	6.4	27	22

To protect surfaces from galling at installation, apply a system-compatible lubricant to the nose and threads of the coned end.

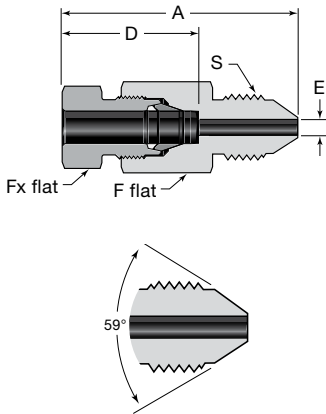

Male, One-Piece

Tube OD	C&T Tube Size in.	Ordering Number	S Thread Size	Dimensions				
				A	D	E	F	Fx
Dimensions, in.								
1/4	1/4	SS-4FK0-1-4MP	7/16-20 UN	1.94	1.08	0.11	5/8	9/16
	3/8	SS-4FK0-1-6MP	9/16-18 UN	2.17	1.08	0.13	5/8	9/16
3/8	3/8	SS-6FK0-1-6MP	9/16-18 UN	2.42	1.34	0.21	3/4	11/16
	9/16	SS-6FK0-1-9MP	13/16-16 UN	2.48	1.34	0.21	7/8	11/16
1/2	9/16	SS-8FK0-1-9MP	13/16-16 UN	2.87	1.59	0.28	1	7/8
9/16	9/16	SS-9FK0-1-9MP	13/16-16 UN	3.06	1.75	0.31	1 1/8	1 1/16
3/4	9/16	SS-12FK0-1-9MP	13/16-16 UN	3.73	2.29	0.31	1 1/2	1 3/8
	3/4	SS-12FK0-1-12MP	3/4-14 NPSM	3.82	2.29	0.45	1 1/2	1 3/8
Dimensions, mm								
6	1/4	SS-6MFK0-1-4MP	7/16-20 UN	49.3	27.4	2.7	16	15
10	3/8	SS-10MFK0-1-6MP	9/16-20 UN	70.1	40.4	5.3	24	22
12	9/16	SS-12MFK0-1-9MP	13/16-16 UN	72.9	40.4	6.4	27	22

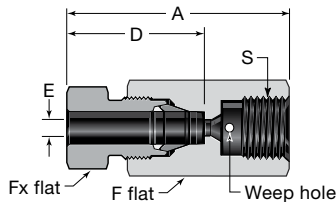

Female^①

Tube OD	C&T Tube Size in.	Ordering Number	S Thread Size	Dimensions				
				A	D	E	F	Fx
Dimensions, in.								
1/4	1/4	SS-4FK0-7-4MP	7/16-20 UN	1.89	1.08	0.11	11/16	9/16
3/8	3/8	SS-6FK0-7-6MP	9/16-18 UN	2.21	1.34	0.20	7/8	11/16
1/2	9/16	SS-8FK0-7-9MP	13/16-16 UN	2.72	1.59	0.38	1 1/16	7/8
9/16	9/16	SS-9FK0-7-9MP	13/16-16 UN	2.86	1.75	0.36	1 1/8	1 1/16
3/4	3/4	SS-12FK0-7-12MP	3/4-14 NPSM	3.80	2.29	0.44	1 1/2	1 3/8
Dimensions, mm								
6	1/4	SS-6MFK0-7-4MP	7/16-20 UN	48.0	27.4	2.7	18	15
10	3/8	SS-10MFK0-7-6MP	9/16-18 UN	64.8	40.4	5.1	24	22
12	9/16	SS-12MFK0-7-9MP	13/16-16 UN	69.1	40.4	6.4	27	22

^① C&T collars and gland are not included. See page 1071 for ordering information.

Straight Fittings

Reducers

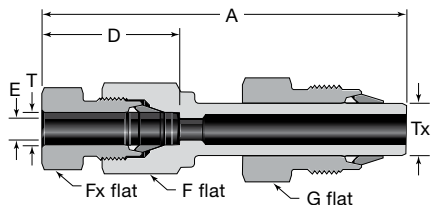

Tube OD, in.		Ordering Number	Dimensions, in.					
T	Tx		A	D	E	F	Fx	G
1/4	3/8	SS-4FK0-R-6FK	2.97	1.08	0.13	5/8	9/16	11/16
	1/2	SS-4FK0-R-8FK	3.31	1.08	0.13	5/8	9/16	7/8
3/8	1/2	SS-6FK0-R-8FK	3.52	1.34	0.21	3/4	11/16	7/8
1/2	3/8	SS-8FK0-R-6FK	3.65	1.59	0.21	1	7/8	11/16
	3/4	SS-8FK0-R-12FK	4.66	1.59	0.38	1	7/8	1 3/8
9/16	3/4	SS-9FK0-R-12FK	4.79	1.75	0.41	1 1/8	1 1/16	1 3/8
3/4	9/16	SS-12FK0-R-9FK	4.93	2.29	0.31	1 1/2	1 3/8	1 1/16

Reducers are furnished with nuts and preswaged ferrules. See page 1062 for installation information.

Port Connectors

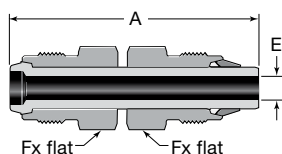

Tube OD	Ordering Number	Dimensions		
		A	E	Fx
Dimensions, in.				
1/4	SS-4FK0-PC	2.06	0.12	9/16
3/8	SS-6FK0-PC	2.54	0.21	11/16
1/2	SS-8FK0-PC	2.99	0.28	7/8
9/16	SS-9FK0-PC	3.22	0.31	1 1/16
3/4	SS-12FK0-PC	4.22	0.42	1 3/8
Dimensions, mm				
6	SS-6MFK0-PC	52.3	3.0	15
10	SS-10MFK0-PC	75.9	5.6	22
12	SS-12MFK0-PC	75.9	6.4	22

Port connectors are furnished with nuts and preswaged ferrules. See page 1062 for installation information.

Caps and Plugs

Cap

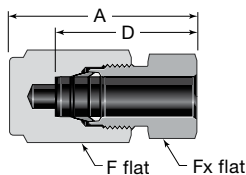

Plug

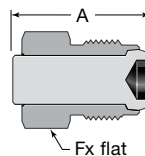

Tube OD	Ordering Number	Dimensions			
		A	D	F	Fx
Dimensions, in.					
1/4	SS-4FK0-C	1.33	1.08	5/8	9/16
3/8	SS-6FK0-C	1.74	1.34	3/4	11/16
1/2	SS-8FK0-C	2.05	1.59	1	7/8
9/16	SS-9FK0-C	2.19	1.75	1 1/8	1 1/16
3/4	SS-12FK0-C	2.86	2.29	1 1/2	1 3/8
Dimensions, mm					
6	SS-6MFK0-C	33.7	27.4	16	15
10	SS-10MFK0-C	52.0	40.4	24	22
12	SS-12MFK0-C	52.0	40.4	27	22

Tube OD	Ordering Number	Dimensions	
		A	Fx
Dimensions, in.			
1/4	SS-4FK0-P	1.03	9/16
3/8	SS-6FK0-P	1.26	11/16
1/2	SS-8FK0-P	1.45	7/8
9/16	SS-9FK0-P	1.50	1 1/16
3/4	SS-12FK0-P	1.98	1 3/8
Dimensions, mm			
6	SS-6MFK0-P	26.2	15
10	SS-10MFK0-P	36.7	22
12	SS-12MFK0-P	36.7	22

90° Elbows

Unions

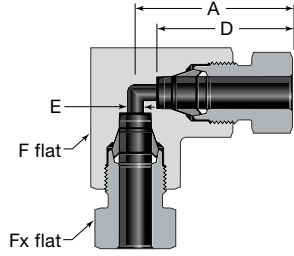

Union

Tube OD	Ordering Number	Dimensions				
		A	D	E	F, in.	Fx
Dimensions, in.						
1/4	SS-4FK0-9	1.26	1.08	0.13	5/8	9/16
3/8	SS-6FK0-9	1.58	1.34	0.21	3/4	11/16
1/2	SS-8FK0-9	1.87	1.59	0.38	1	7/8
9/16	SS-9FK0-9	2.18	1.75	0.41	1 1/2	1 1/16
3/4	SS-12FK0-9	2.83	2.29	0.56	1 1/2	1 3/8
Dimensions, mm						
6	SS-6MFK0-9	31.9	27.4	3.0	5/8	15
10	SS-10MFK0-9	47.5	40.4	5.6	1	22
12	SS-12MFK0-9	47.5	40.4	6.4	1	22

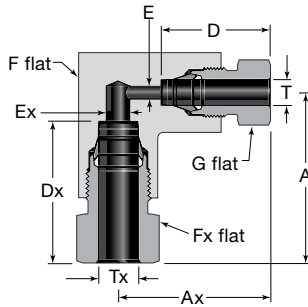

Reducing Union

Tube OD		Ordering Number	Dimensions									
T	Tx		A	Ax	D	Dx	E	Ex	F, in.	Fx	G	
Dimensions, in.												
1/4	3/8	SS-6FK0-9-4	1.61	1.48	1.08	1.34	0.13	0.21	3/4	11/16	9/16	
	1/2	SS-8FK0-9-4	1.91	1.69	1.08	1.59	0.13	0.38	1	7/8	9/16	
3/8	1/2	SS-8FK0-9-6	1.91	1.82	1.34	1.59	0.21	0.38	1	7/8	11/16	
1/2	9/16	SS-9FK0-9-8	2.18	2.14	1.59	1.75	0.38	0.41	1 1/2	1 1/16	7/8	
	3/4	SS-12FK0-9-8	2.83	2.51	1.59	2.29	0.38	0.56	1 1/2	1 3/8	7/8	
Dimensions, mm												
6	10	SS-10MFK0-9-6M	48.5	42.8	27.4	40.4	3.2	5.6	1	22	15	
	12	SS-12MFK0-9-6M	48.5	42.8	27.4	40.4	3.2	6.4	1	22	22	
10	12	SS-12MFK0-9-10M	48.5	48.5	40.4	40.4	5.6	6.4	1	22	22	

Male

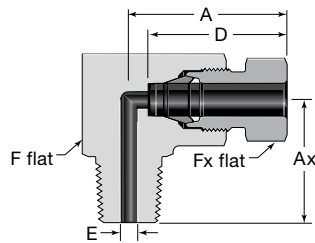

NPT

Tube OD	NPT Size in.	Ordering Number	Dimensions					
			A	Ax	D	E	F, in.	Fx
Dimensions, in.								
1/4	1/4	SS-4FK0-2-4	1.46	0.97	1.08	0.13	3/4	9/16
	3/8	SS-4FK0-2-6	1.46	0.97	1.08	0.13	3/4	9/16
	1/2	SS-4FK0-2-8	1.67	1.37	1.08	0.13	1	9/16
3/8	1/4	SS-6FK0-2-4	1.59	0.97	1.34	0.21	3/4	11/16
	3/8	SS-6FK0-2-6	1.59	0.97	1.34	0.21	3/4	11/16
	1/2	SS-6FK0-2-8	1.80	1.37	1.34	0.21	1	11/16
1/2	1/4	SS-8FK0-2-4	1.88	1.18	1.59	0.25	1	7/8
	3/8	SS-8FK0-2-6	1.88	1.18	1.59	0.33	1	7/8
	1/2	SS-8FK0-2-8	1.88	1.37	1.59	0.38	1	7/8
9/16	1/2	SS-9FK0-2-8	2.18	1.73	1.75	0.41	1 1/2	1 1/16
3/4	1/2	SS-12FK0-2-8	2.83	1.73	2.29	0.41	1 1/2	1 3/8
	3/4	SS-12FK0-2-12	2.83	1.73	2.29	0.56	1 1/2	1 3/8
Dimensions, mm								
6	1/4	SS-6MFK0-2-4	37.0	24.6	27.4	3.2	3/4	15
10	3/8	SS-10MFK0-2-6	47.8	30.0	40.4	5.6	1	22
12	1/2	SS-12MFK0-2-8	47.8	34.8	40.4	6.3	1	22

Tees

Unions

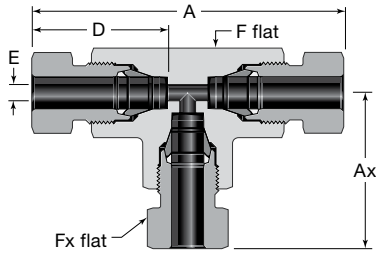

Tube OD	Ordering Number	Dimensions					
		A	Ax	D	E	F, in.	Fx
Dimensions, in.							
1/4	SS-4FK0-3	2.51	1.26	1.08	0.13	5/8	9/16
3/8	SS-6FK0-3	3.17	1.58	1.34	0.21	3/4	11/16
1/2	SS-8FK0-3	3.74	1.87	1.59	0.38	1	7/8
9/16	SS-9FK0-3	4.36	2.18	1.75	0.41	1 1/2	1 1/16
3/4	SS-12FK0-3	5.66	2.83	2.29	0.56	1 1/2	1 3/8
Dimensions, mm							
6	SS-6MFK0-3	63.8	31.9	27.4	3.2	5/8	15
10	SS-10MFK0-3	94.9	47.5	40.4	5.6	1	22
12	SS-12MFK0-3	94.9	47.5	40.4	6.4	1	22

Male Branch, NPT (TTM)

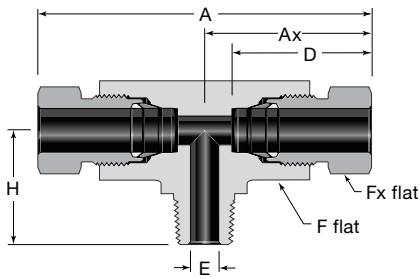

Tube OD	NPT Size in.	Ordering Number	Dimensions						
			A	Ax	D	E	H	F, in.	Fx
Dimensions, in.									
1/4	1/8	SS-4FK0-3TTM	2.51	1.26	1.08	0.13	0.78	5/8	9/16
	1/4	SS-4FK0-3-4TTM	2.92	1.46	1.08	0.13	0.97	3/4	9/16
3/8	1/4	SS-6FK0-3TTM	3.17	1.58	1.34	0.21	0.97	3/4	11/16
1/2	1/4	SS-8FK0-3-4TTM	3.74	1.87	1.59	0.25	1.18	1	7/8
	3/8	SS-8FK0-3TTM	3.74	1.87	1.59	0.38	1.18	1	7/8
3/4	3/4	SS-12FK0-3TTM	5.66	2.83	2.29	0.56	1.81	1 1/2	1 3/8
Dimensions, mm									
6	1/8	SS-6MFK0-3TTM	63.8	31.9	27.4	3.2	19.8	5/8	15
10	1/4	SS-10MFK0-3TTM	94.9	47.5	40.4	5.6	30.0	1	22
12	3/8	SS-12MFK0-3TTM	94.9	47.5	40.4	6.4	30.0	1	22

Crosses

Unions

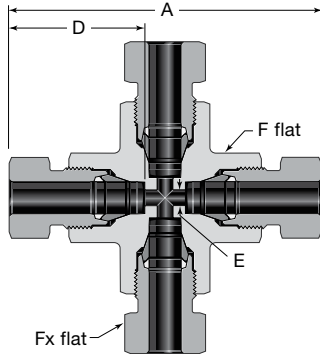

Tube OD	Ordering Number	Dimensions				
		A	D	E	F, in.	Fx
Dimensions, in.						
1/4	SS-4FK0-4	2.51	1.08	0.13	5/8	9/16
3/8	SS-6FK0-4	3.17	1.34	0.21	3/4	11/16
1/2	SS-8FK0-4	3.74	1.59	0.38	1	7/8
Dimensions, mm						
6	SS-6MFK0-4	63.8	27.4	3.0	5/8	15
10	SS-10MFK0-4	94.9	40.5	5.6	1	22
12	SS-12MFK0-4	94.9	40.5	6.4	1	22

Tube Adapters

Male NPT

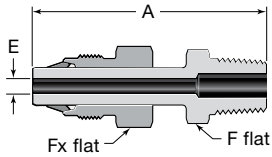

Tube OD in.	NPT Size in.	Ordering Number	Dimensions, in.			
			A	E	F	Fx
1/4	1/4	SS-4FK-TA-1-4	2.18	0.12	9/16	9/16
3/8	1/4	SS-6FK-TA-1-4	2.53	0.21	9/16	11/16
	1/2	SS-6FK-TA-1-8	2.78	0.21	7/8	11/16
1/2	1/4	SS-8FK-TA-1-4	2.87	0.25	9/16	7/8
	1/2	SS-8FK-TA-1-8	3.12	0.28	7/8	7/8
9/16	1/2	SS-9FK-TA-1-8	3.28	0.31	7/8	1 1/16
3/4	3/4	SS-12FK-TA-1-12	3.92	0.42	1 1/16	1 3/8

Tube adapters are furnished with nuts and preswaged ferrules. See page 1062 for installation information.

Installation Instructions

Medium-Pressure Tube Fitting Assembly—FK Series

These instructions apply to medium-pressure tube fitting sizes from 1/4 in./6 mm to 3/4 in./12 mm. For 3/4 in. medium-pressure tube fittings *only*, you can use the Swagelok multihead hydraulic swaging unit (MHSU) to preswage the ferrules onto the tube and install in accordance with **Connections Preswaged with the MHSU**, page 1062.

Fig. 1

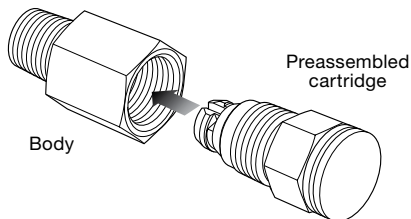

1. Thread the preassembled cartridge (nut, ferrules, and plastic arbor) into the fitting body until finger-tight (Fig. 1).

For temperatures above 400°F (204°C), Silver Goop™ high-temperature thread lubricant is recommended for use on fitting nut threads.

Fig. 2

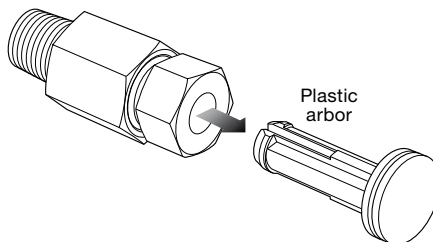

2. Remove the plastic arbor (Fig. 2).

Fig. 3

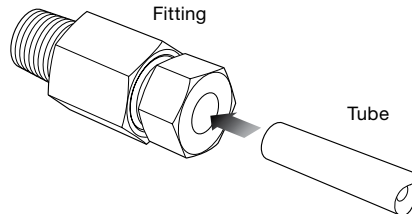

3. Insert the tube into the fitting (Fig. 3).

Fig. 4

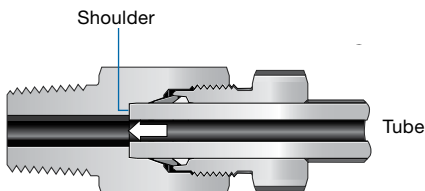

All Sizes

4. Make sure that the tube rests firmly on the shoulder of the fitting body (Fig. 4).

Fig. 5

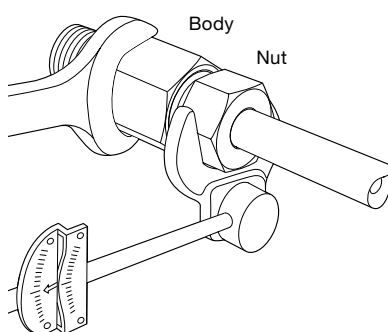

9/16 in./12 mm and Smaller Sizes

5. Hold the body steady and tighten the nut to the specified torque (Fig. 5).

Tube OD	Required Torque	
	ft·lb	N·m
1/4 in., 6 mm	25	33.9
3/8 in.	45	61.1
10 mm	100	136
1/2 in., 12 mm	110	150
9/16 in.	170	231

Alternatively, mark the nut, then tighten the nut one full turn (Fig. 6).

6. Use the Swagelok medium-pressure gap inspection gauge to ensure that the fitting has been tightened sufficiently.

Fig. 6

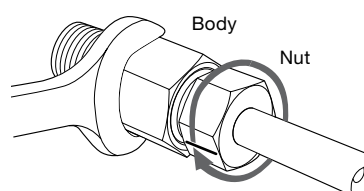

3/4 in. Size

5. Mark the nut, then hold the body steady and tighten the nut one full turn (Fig. 6).
6. Use the Swagelok medium-pressure gap inspection gauge to ensure that the fitting has been tightened sufficiently.

Installation Instructions

Connections Preswaged with the MHSU

These instructions apply to 3/4 in. medium-pressure tube fittings *only*. These fittings can also be assembled in accordance with **Medium-Pressure Tube Assembly—FK Series**, page 1061.

Fig. 1

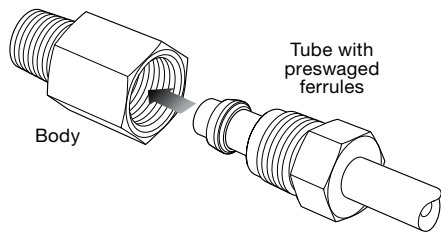

1. Preswage the ferrules onto the tube using a Swagelok multihead hydraulic swaging unit (MHSU) and the appropriate medium-pressure tooling.

See the *Multihead Hydraulic Swaging Unit (MHSU) Setup and Operating Instructions*, MS-12-37.

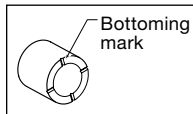

2. Inspect the tube end for a bottoming mark. This radial indentation indicates the tube was properly bottomed in the MHSU. If there is not a visible indentation, the preswaged assembly should not be used.

Fig. 2

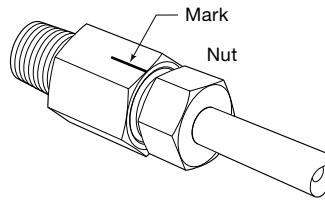

The MHSU should be used to preswage a set of ferrules only one time. If the ferrules were insufficiently preswaged, they should be discarded and the process started again with a new set of ferrules.

3. Insert the tube with preswaged ferrules into the fitting until the front ferrule seats against the fitting body; rotate the nut finger-tight (Fig. 1).

For temperatures above 400°F (204°C), Silver Goop high-temperature thread lubricant is recommended for use on fitting nut threads.

4. Place a mark on the fitting body in line with one of the hex points of the nut (Fig. 2).

Fig. 3

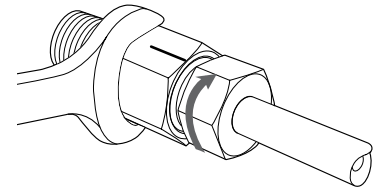

5. Hold the fitting body steady and tighten the nut one-third turn (Fig. 3). This is equivalent to advancing the nut two hex points from the mark. *Alternatively, hold the fitting body steady and tighten the nut to the specified torque.*

Tube OD	Required Torque	
	ft-lb	N·m
3/4 in.	225	306

6. Use the Swagelok medium-pressure gap inspection gauge to ensure that the fitting has been tightened sufficiently.

Caps and Plugs

Caps Installation

See **Medium-Pressure Tube Fitting Assembly—FK Series**, page 1061.

Plugs Installation

Hold the body steady and tighten the plug to the specified torque.

Tube OD	Required Torque	
	ft·lb	N·m
1/4 in., 6 mm	25	33.9
3/8 in.	45	61.1
10 mm	100	136
1/2 in., 12 mm	110	150
9/16 in.	170	231
3/4 in.	225	306

Alternatively, tighten the plug one-quarter turn from the finger-tight position.

Port Connectors Installation

For installation of the machined ferrule end of the port connector, see **Plugs Installation**, this page.

For installation of the pre-swaged ferrule end of the port connector, see **Tube Adapters and Reducers Installation**, this page.

Tube Adapters and Reducers Installation

For initial installation, insert the tube with preswaged ferrules into the body; rotate the nut finger-tight.

For temperatures above 400°F (204°C), Silver Goop high-temperature thread lubricant is recommended for use on fitting nut threads.

- For preswaged 9/16 in. or 12 mm and smaller fittings, hold the body steady and rotate the nut to the previously pulled-up position. At this point, you will feel a significant increase in resistance. Tighten the nut an additional one-fourth turn.
- For preswaged 3/4 in. fittings, hold the fitting body steady and tighten the nut one-third turn.

*Alternatively, hold the fitting body steady and tighten the nut to the torque specified in **Plugs Installation**, this page.*

Installation Instructions

Preswaging Tool

These instructions apply to medium-pressure tube fitting sizes from 1/4 in./6 mm to 9/16 in./12 mm.

Fig. 1

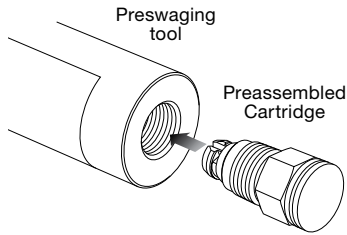

Fig. 2

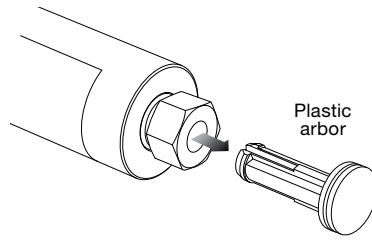

Fig. 3

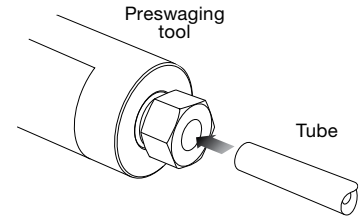

Fig. 4

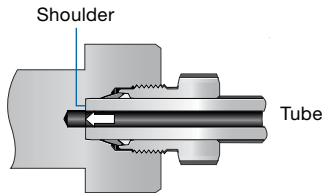

Fig. 5

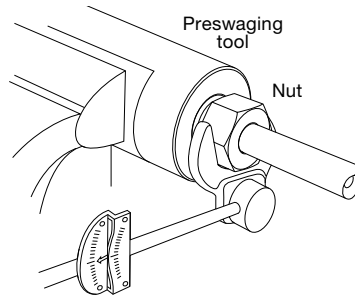

Fig. 6

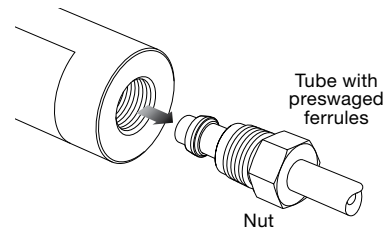

Fig. 7

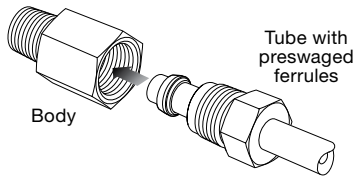
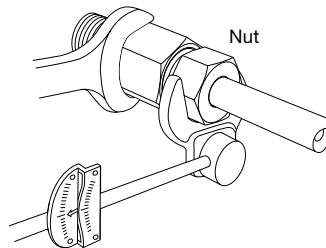

Fig. 8



1. Thread the preassembled cartridge (nut, ferrules, and plastic arbor) into the preswaging tool until finger-tight (Fig. 1).
2. Remove the plastic arbor (Fig. 2).
3. Insert the tube into the preswaging tool (Fig. 3).
4. Make sure that the tube rests firmly on the shoulder of the preswaging tool body; rotate the nut finger-tight (Fig. 4).

5. Hold the preswaging tool steady and tighten the nut to the specified torque (Fig. 5).

Tube OD	Required Torque	
	ft·lb	N·m
1/4 in., 6 mm	25	33.9
3/8 in.	45	61.1
10 mm	100	136
1/2 in., 12 mm	110	150
9/16 in.	170	231

Alternatively, mark the nut and tighten the nut three-quarters turn.

6. Loosen the nut.
7. Remove the tube with preswaged ferrules from the preswaging tool (Fig. 6).

If the tube sticks in the preswaging tool, remove the tube by gently rocking it back and forth. Do not turn the tube.

8. Insert the tube with preswaged ferrules into the fitting until the front ferrule seats against the fitting body; rotate the nut finger-tight (Fig. 7).

For temperatures above 400°F (204°C), Silver Goop high-temperature thread lubricant is recommended for use on fitting nut threads.

9. Rotate the nut with a wrench and tighten to the specified torque shown in step 5 (Fig. 8).

Alternatively, rotate the nut to the previously pulled-up position. At this point, you will feel a significant increase in resistance. Tighten the nut an additional one-fourth turn with a wrench.

- ⚠ Do not use a gap inspection gauge with fittings that were assembled using the preswaging tool.**

Installation Instructions

Medium-Pressure Tube Fitting Reassembly—FK Series

Fig. 1

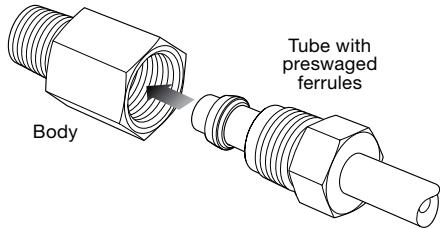

Fig. 2

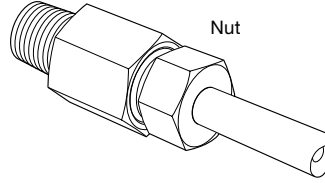
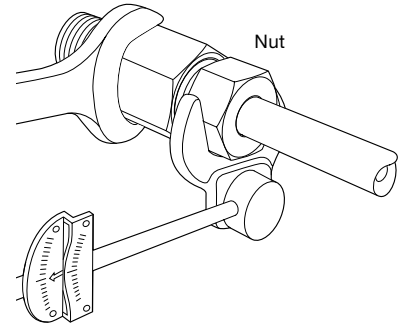

Fig. 3



You may disassemble and reassemble Swagelok medium-pressure tube fittings many times.

1. Insert tube with preswaged ferrules into the fitting body until the front ferrule seats; rotate the nut finger-tight. (Fig. 1, 2)

2. Rotate the nut with a wrench and tighten to the specified torque (Fig. 3).

Tube OD	Required Torque	
	ft-lb	N·m
1/4 in., 6 mm	25	33.9
3/8 in.	45	61.1
10 mm	100	136
1/2 in., 12 mm	110	150
9/16 in.	170	231
3/4 in.	225	306

Alternatively, rotate the nut with a wrench to the previously pulled-up position. At this point, you will feel a significant increase in resistance. Tighten the nut slightly with a wrench.

⚠ Do not use a gap inspection gauge with reassembled fittings.

Replacement Parts

Nut and Ferrules Cartridge

Each cartridge contains a front ferrule, back ferrule, and male nut. Fractional cartridges are assembled on red arbors; metric cartridges are assembled on yellow arbors.

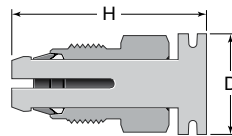

⚠ Do not use medium-pressure nut and ferrules with any other Swagelok tube fittings.

Tube OD	Ordering Number	Dimensions	
		D	H
Dimensions, in.			
1/4	SS-4FK-NFSET	0.69	1.43
3/8	SS-6FK-NFSET	0.81	1.72
1/2	SS-8FK-NFSET	1.00	1.97
9/16	SS-9FK-NFSET	1.10	2.05
3/4	SS-12FK-NFSET	1.60	2.59
Dimensions, mm			
6	SS-6MFK-NFSET	17.5	36.4
10	SS-10MFK-NFSET	25.4	49.9
12	SS-12MFK-NFSET	25.4	49.9

Tools and Accessories

Preswaging Tool



For Swagelok tube fitting installations in close quarters, the Swagelok preswaging tool is a convenient accessory.

Tube OD	Ordering Number
Dimensions, in.	
1/4	MS-ST-4FK0
3/8	MS-ST-6FK0
1/2	MS-ST-8FK0
9/16	MS-ST-9FK0
Dimensions, mm	
6	MS-ST-6MFK0
10	MS-ST-10MFK0
12	MS-ST-12MFK0

Depth Marking Tool



Swagelok depth marking tools help ensure that tubing is bottomed on the shoulder inside the Swagelok tube fitting body.

Tube OD	Ordering Number
Dimensions, in.	
1/4	MS-DMT-4FK0
3/8	MS-DMT-6FK0
1/2	MS-DMT-8FK0
9/16	MS-DMT-9FK0
3/4	MS-DMT-12FK0
Dimensions, mm	
6	MS-DMT-6MFK0
10	MS-DMT-10MFK0
12	MS-DMT-12MFK0

Multihead Hydraulic Swaging Unit (MHSU)

- For preswaging Swagelok 3/4 in. medium-pressure ferrules onto tubing.
 - Is standard with a tube marking feature to indicate when tube is properly bottomed.
 - Requires the 1 in./25mm and over MHSU unit and medium-pressure tooling.
- ⚠ **The MHSU cannot be used for preswaging 9/16 in./12 mm and under medium-pressure fittings.**



1 in. or 25 mm and Over MHSU Unit Components

- Multihead hydraulic swaging unit
- 6 ft (1.8 m) hydraulic hose
- Retaining ring pliers
- Safety glasses
- Operating instructions
- Carrying case.

Medium-Pressure Tooling Kit Components

- Die head set for Swagelok 3/4 in. medium-pressure tube fitting
- Gap inspection gauge.

Description	Ordering Number
MHSU only (1 in./25 mm and over size)	MS-MHSU-O-E
3/4 in. medium-pressure tooling	MS-MHSUT-O-12FK-M

See the Swagelok *Gaugeable Tube Fittings and Adapter Fittings* catalog, MS-01-140, for more information about the MHSU.

See the Swagelok *Multihead Hydraulic Swaging Unit (MHSU) Setup and Operating Instructions*, MS-12-37, for instructions.

Tools and Accessories

Medium-Pressure Gap Inspection Gauge

The Swagelok medium-pressure gap inspection gauge assures the installer or inspector that the fitting has been sufficiently pulled up on initial installation, whether using a torque wrench, standard wrench tightening, or preswaging with the MHSU.

⚠ The medium-pressure gap inspection gauge is different from the gap gauge for all other Swagelok tube fittings.



Tube OD	Ordering Number
Dimensions, in.	
1/4, 3/8, 1/2	MS-IG-FK0
9/16	MS-IG-9FK0
3/4	MS-IG-12FK0
Dimensions, mm	
6	MS-IG-6MFK0
10	MS-IG-10MFK0
12	MS-IG-12MFK0

Tubing Selection

Swagelok medium-pressure FK series tube fittings can be used with 316 stainless tubing or Alloy 2507 super duplex tubing.

- For 316 stainless steel tubing, see the Tubing/Fitting Compatibility matrix on page 1105.
- For Alloy 2507 super duplex tubing, see the Swagelok *Alloy 2507 Seamless Super Duplex Tubing—Fractional Sizes* catalog (MS-02-151), page 203.

Cone and Thread Fittings —IPT Series

For Pressures up to 60 000 psig
(4134 bar)



- 316 stainless steel construction
- Temperatures up to 1000°F (537°C)
- Medium-pressure (MP) fittings
 - Size range—1/4 to 1 1/2 in.
 - Pressure rating—up to 20 000 psig (1378 bar)
- High-pressure (HP) fittings
 - Size range—1/4 to 9/16 in.
 - Pressure rating—up to 60 000 psig (4134 bar)

Contents

Features, 1068

Materials of Construction, 1068

Pressure Ratings, 1068

Cleaning and Packaging, 1068

Dimensions—Cone & Thread End Connections, 1069

Ordering Information and Dimensions, 1069

Couplings, Elbows 1069

Tees, Crosses, Bulkheads, 1070



Caps and Plugs, 1071



Collars and Glands, 1071



Safety Heads and Line Filters, 1071



Options and Accessories

- Anti-vibration, 1072
- NACE-Compliant Fittings, 1072
- Rupture Discs, 1073

Installation Instructions,

- Medium-Pressure Cone and Thread Fitting Assembly, 1073
- High-Pressure Cone and Thread Fitting Assembly, 1074

Cone and Thread Fitting—IPT Series

Medium-pressure cone and thread end connection shown on left side of fitting

High-pressure cone and thread end connection shown on right side of fitting

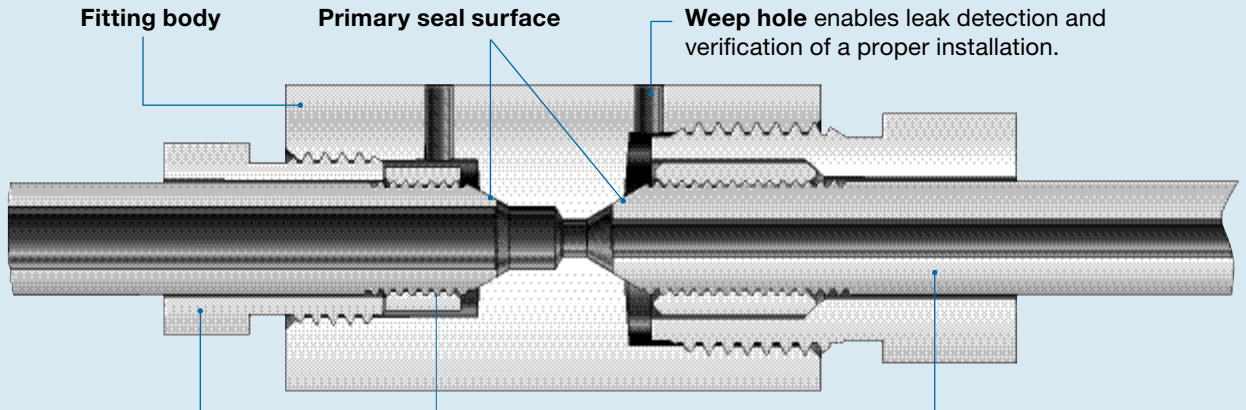

Gland creates a load on the collar to ensure a seal on the tubing and body angle area.

Collar threads onto the cone and thread tubing with left-hand threads to prevent accidental disassembly of collar during installation.

Weep hole enables leak detection and verification of a proper installation.

Cone and thread tubing is required for cone and thread fitting installation. High-pressure tubing has a thicker wall than medium-pressure tubing. See the Tubing/Fitting Compatibility matrix on page 1105.

Features

- Cone and thread (C&T) connection provides dependable medium- and high-pressure performance.
- Weep holes standard on all pressure connections to verify proper connection.
- Female, medium- and high-pressure C&T fittings, adapters, and couplings are supplied complete with glands and collars except where noted.
- C&T fittings can be manufactured to meet NACE MR0175/ISO 15156.
- Anti-vibration connection components are available.

Materials of Construction

- Strain-hardened 316 stainless steel standard
- Other materials available on request

Component	Material/ASTM Specification
<i>Body</i>	316 SS/A276, A479
Gland	316 SS/A276
Collar	316 SS/A276

Wetted components listed in *italics*.

Cleaning and Packaging

All cone and thread fittings are cleaned in accordance with Swagelok *Standard Cleaning and Packaging (SC-10)* (MS-06-62), page 1174.

Pressure Ratings

Pressure ratings are dependent on the end connection or system component with the lowest pressure rating. Working pressure determined based on ASME B31.3 Process Piping, Chapter IX High Pressure Piping.

- **Medium-pressure** cone and thread end connections are rated to 20 000 psig (1378 bar).
- **High-pressure** cone and thread end connections are rated to 60 000 psig (4134 bar)

Elevated Temperature Factors

To determine allowable working pressure at elevated temperatures, multiply allowable working pressures shown above by a factor shown in the table below.

Temperature		Factors	
°F	°C	Strain-Hardened 316 SS	Annealed 316 SS
-60 to 200	-51 to 93	1.00	1.00
400	204	0.93	0.96
600	315	0.93	0.85
800	426	0.92	0.79
1000	537	0.84	0.76

Dimensions—Cone & Thread End Connections

Dimensions are for reference only and are subject to change.

Female pocket

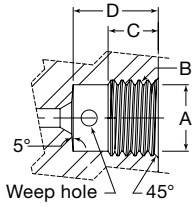

Female seat

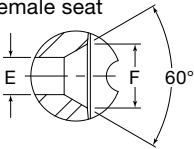

Male coned tube

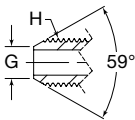

Fitting Size in.	Dimensions, in. (mm)								Tube Engagement Length
	A	B	C	D	E	F	G	H	
Medium Pressure: 20 000 psig (1378 bar)									
1/4	0.39 (9.9)	7/16-20	0.28 (7.1)	0.50 (12.7)	0.11 (2.8)	0.19 (4.6)	0.14 (3.6)	1/4-28	0.56 (14.2)
3/8	0.52 (13.2)	9/16-18	0.38 (9.7)	0.63 (16.0)	0.20 (5.1)	0.36 (9.1)	0.25 (6.4)	3/8-24	0.69 (17.5)
9/16	0.75 (19.0)	13/16-16	0.44 (11.2)	0.75 (19.0)	0.31 (7.9)	0.50 (12.7)	0.41 (10.4)	9/16-18	0.84 (21.3)
3/4	0.95 (24.1)	3/4-14 NPSM	0.70 (17.8)	0.94 (23.9)	0.44 (11.2)	0.63 (16.0)	0.56 (14.2)	3/4-16	1.00 (25.4)
1	1.30 (33.0)	1 3/8-12	0.81 (20.6)	1.31 (33.3)	0.56 (14.2)	0.88 (22.4)	0.72 (18.3)	1-14	1.47 (37.3)
1 1/2	1.80 (45.8)	1 7/8-12	1.00 (25.4)	1.60 (40.6)	0.94 (23.8)	1.35 (34.3)	1.13 (28.6)	1 1/2-12	1.81 (46.0)
High Pressure: 60 000 psig (4134 bar)									
1/4	0.52 (13.2)	9/16-18	0.38 (9.7)	0.44 (11.2)	0.09 (2.3)	0.17 (4.3)	0.13 (3.3)	1/4-28	0.50 (12.7)
3/8	0.69 (17.5)	3/4-16	0.53 (13.5)	0.63 (16.0)	0.13 (3.3)	0.27 (6.9)	0.22 (5.6)	3/8-24	0.69 (17.5)
9/16	1.05 (26.7)	1 1/8-12	0.62 (15.7)	0.75 (19.0)	0.19 (4.6)	0.38 (9.7)	0.28 (7.1)	9/16-18	0.88 (22.4)

⚠ When interchanging anti-vibration glands, it is recommended to install per the gland manufacturers instructions.

Ordering Information and Dimensions

Dimensions are for reference only and are subject to change. Dimensions shown with cone and thread nuts finger-tight.

Couplings

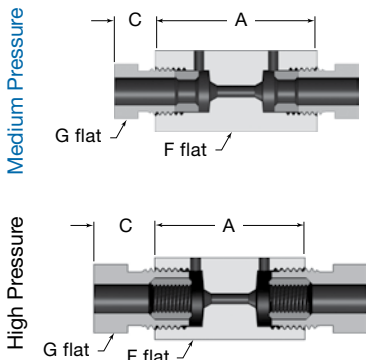

Tube OD in.	Ordering Number	Dimensions, in. (mm)			
		A	C	F	G
Medium Pressure: 20 000 psig (1378 bar)					
1/4	CN4MF20	1.50 (38.1)	0.38 (9.7)	3/4	1/2
3/8	CN6MF20	1.75 (44.5)	0.48 (12.2)	3/4	5/8
9/16	CN9MF20	2.12 (53.8)	0.68 (17.3)	1	7/8
3/4	CN12MF20	2.50 (63.5)	0.59 (15.0)	1 3/8	1 3/16
1	CN16MF20	3.50 (88.9)	0.74 (18.8)	1 3/4	1 3/8
1 1/2	CN24MF15	4.38 (111.2)	1.10 (27.9)	2 1/4	1 7/8
High Pressure: 60 000 psig (4134 bar)					
1/4	CN4HF60	1.38 (35.1)	0.59 (15.0)	3/4	5/8
3/8	CN6HF60	1.75 (44.5)	0.72 (18.3)	1	13/16
9/16	CN9HF60	2.25 (57.2)	1.00 (25.4)	1 3/8	1 3/16

Elbows

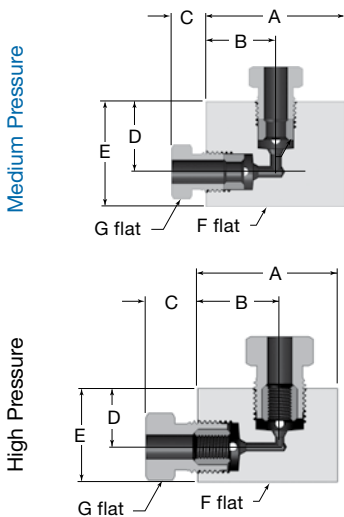

Tube OD in.	Ordering Number	Dimensions, in. (mm)						
		A	B	C	D	E	F	G
Medium Pressure: 20 000 psig (1378 bar)								
1/4	L4MF20	1.50 (38.1)	0.75 (19.1)	0.38 (9.7)	0.75 (19.1)	1.13 (28.6)	5/8	1/2
3/8	L6MF20	2.00 (50.8)	1.00 (25.4)	0.48 (12.2)	1.00 (25.4)	1.38 (35.1)	3/4	5/8
9/16	L9MF20	2.50 (63.5)	1.25 (31.8)	0.68 (17.3)	1.25 (31.8)	1.75 (44.5)	1	7/8
3/4	L12MF20	3.00 (76.2)	1.50 (38.1)	0.59 (15)	1.50 (38.1)	2.25 (57.2)	1 3/8	1 3/16
1	L16MF20	4.13 (105)	2.06 (52.3)	0.74 (18.8)	2.06 (52.3)	3.00 (76.2)	1 3/4	1 3/8
1 1/2	L24MF15	5.75 (146)	2.88 (73.2)	1.10 (27.9)	2.88 (73.2)	4.00 (102)	2 1/4	1 7/8
High Pressure: 60 000 psig (4134 bar)								
1/4	L4HF60	1.50 (38.1)	0.88 (22.4)	0.59 (15)	0.63 (15.9)	1.00 (25.4)	1	5/8
3/8	L6HF60	2.00 (50.8)	1.25 (31.8)	0.72 (18.3)	1.00 (25.4)	1.50 (38.1)	1	13/16
9/16	L9HF60	2.62 (66.5)	1.88 (47.6)	1.00 (25.4)	1.13 (28.6)	1.88 (47.6)	1 1/2	1 3/16

MEDIUM- AND HIGH-PRESSURE

Tees

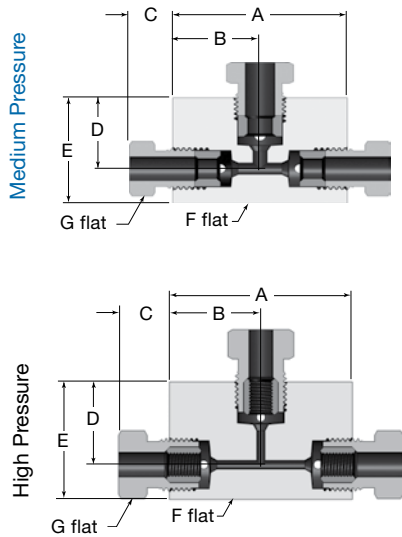

Tube OD in.	Ordering Number	Dimensions, in. (mm)						
		A	B	C	D	E	F	G
Medium Pressure: 20 000 psig (1378 bar)								
1/4	T4MF20	1.50 (38.1)	0.75 (19.1)	0.38 (9.7)	0.75 (19.1)	1.13 (28.6)	5/8	1/2
3/8	T6MF20	2.00 (50.8)	1.00 (25.4)	0.48 (12.2)	1.00 (25.4)	1.38 (35.1)	3/4	5/8
9/16	T9MF20	2.50 (63.5)	1.25 (31.8)	0.68 (17.3)	1.25 (31.8)	1.75 (44.5)	1	7/8
3/4	T12MF20	3.00 (76.2)	1.50 (38.1)	0.59 (15)	1.50 (38.1)	2.25 (57.2)	1 3/8	1 3/16
1	T16MF20	4.12 (105)	2.06 (52.3)	0.74 (18.8)	2.06 (52.3)	3.00 (76.2)	1 3/4	1 3/8
1 1/2	T24MF15	5.75 (146)	2.88 (73.2)	1.10 (27.9)	2.88 (73.2)	4.00 (102)	2 1/4	1 7/8
High Pressure: 60 000 psig (4134 bar)								
1/4	T4HF60	2.00 (50.8)	1.00 (25.4)	0.59 (15)	0.88 (22.4)	1.25 (31.8)	1	5/8
3/8	T6HF60	2.00 (50.8)	1.00 (25.4)	0.72 (18.3)	1.06 (27.0)	1.56 (39.6)	1	13/16
9/16	T9HF60	2.62 (66.5)	1.31 (33.3)	1.00 (25.4)	1.38 (34.9)	2.12 (53.8)	1 1/2	1 3/16

Crosses

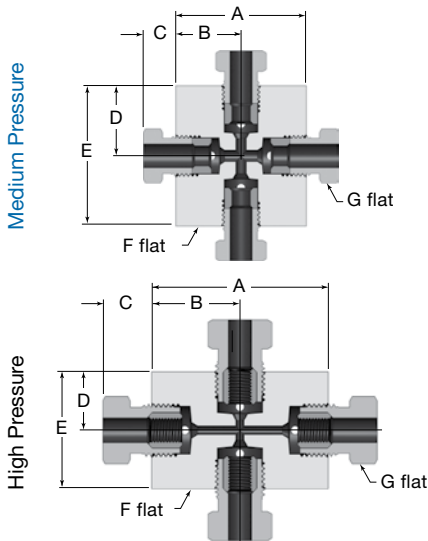

Tube OD in.	Ordering Number	Dimensions, in. (mm)						
		A	B	C	D	E	F	G
Medium Pressure: 20 000 psig (1378 bar)								
1/4	X4MF20	1.50 (38.1)	0.75 (19.1)	0.38 (9.7)	0.75 (19.1)	1.50 (38.1)	5/8	1/2
3/8	X6MF20	2.00 (50.8)	1.00 (25.4)	0.48 (12.2)	1.00 (25.4)	2.00 (50.8)	3/4	5/8
9/16	X9MF20	2.50 (63.5)	1.25 (31.8)	0.68 (17.3)	1.25 (31.8)	2.50 (63.5)	1	7/8
3/4	X12MF20	3.00 (76.2)	1.50 (38.1)	0.59 (15)	1.50 (38.1)	3.00 (76.2)	1 3/8	1 3/16
1	X16MF20	4.12 (105)	2.06 (52.3)	0.74 (18.8)	2.06 (52.3)	4.12 (105)	1 3/4	1 3/8
High Pressure: 60 000 psig (4134 bar)								
1/4	X4HF60	2.00 (50.8)	1.00 (25.4)	0.59 (15.0)	0.63 (16.0)	1.25 (31.8)	1	5/8
3/8	X6HF60	2.00 (50.8)	1.00 (25.4)	0.72 (18.3)	1.06 (27.0)	2.12 (53.8)	1	13/16
9/16	X9HF60	2.62 (66.5)	1.31 (33.3)	1.00 (25.4)	1.38 (34.9)	2.75 (69.8)	1 1/2	1 3/16

Bulkheads

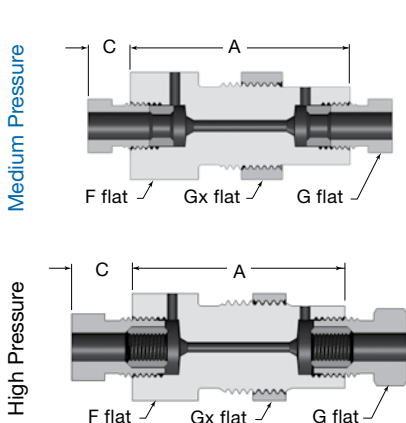

Tube OD in.	Ordering Number	Dimensions, in. (mm)						Panel Hole Size	Panel Thickness Max
		A	C	F	G	Gx			
Medium Pressure: 20 000 psig (1378 bar)									
1/4	BH4MF20	2.00 (50.8)	0.38 (9.7)	1	1/2	1	0.88 (22.4)	0.38 (9.7)	
3/8	BH6MF20	2.00 (50.8)	0.48 (12.2)	1	5/8	1	0.94 (23.9)	0.38 (9.7)	
9/16	BH9MF20	2.62 (66.5)	0.68 (17.3)	1 3/8	7/8	1 3/8	1.25 (31.8)	0.50 (12.7)	
3/4	BH12MF20	2.62 (66.5)	0.59 (15)	1 7/8	1 3/16	1 7/8	1.69 (42.9)	0.38 (9.7)	
1	BH16MF20	3.50 (88.9)	0.74 (18.8)	2 1/8	1 3/8	2 1/8	2.00 (50.8)	0.50 (12.7)	
High Pressure: 60 000 psig (4134 bar)									
1/4	BH4HF60	2.00 (50.8)	0.59 (15.0)	1	5/8	1	0.94 (23.9)	0.50 (12.7)	
3/8	BH6HF60	2.38 (60.5)	0.72 (18.3)	1 3/8	13/16	1 3/8	1.12 (28.4)	0.38 (9.7)	
9/16	BH9HF60	2.75 (69.9)	1.00 (25.4)	1 7/8	1 3/16	1 7/8	1.75 (44.5)	0.62 (15.7)	

MEDIUM- AND HIGH-PRESSURE

Caps and Plugs

Caps

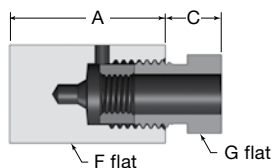

Medium-pressure configuration shown

Plugs



Tube OD in.	Ordering Number	Dimensions, in. (mm)			
		A	C	F	G
Medium Pressure: 20 000 psig (1378 bar)					
1/4	CA4M20	1.00 (25.4)	0.38 (9.7)	5/8	1/2
3/8	CA6M20	1.25 (31.8)	0.48 (12.2)	3/4	5/8
9/16	CA9M20	1.50 (38.1)	0.68 (17.3)	1	7/8
3/4	CA12M20	1.75 (44.5)	0.59 (15)	1 3/8	1 3/16
1	CA16M20	2.25 (57.2)	0.74 (18.8)	1 3/4	1 3/8
High Pressure: 60 000 psig (4134 bar)					
1/4	CA4H60	1.06 (27.0)	0.59 (15)	3/4	5/8
3/8	CA6H60	1.25 (31.8)	0.72 (18.3)	1	13/16
9/16	CA9H60	1.62 (41.2)	1.00 (25.4)	1 3/8	1 3/16

Tube OD in.	Ordering Number	Dimensions, in. (mm)	
		A	D
Medium Pressure: 20 000 psig (1378 bar)			
1/4	PL4M	1.00 (25.4)	0.25 (6.4)
3/8	PL6M	1.25 (31.8)	0.38 (9.5)
9/16	PL9M	1.56 (39.6)	0.56 (14.2)
3/4	PL12M	1.62 (41.2)	0.75 (19.5)
1	PL16M	2.19 (55.6)	1.00 (25.4)
1 1/2	PL24M	3.01 (76.5)	1.50 (38.1)
High Pressure: 60 000 psig (4134 bar)			
1/4	PL4H	1.16 (29.4)	0.25 (6.4)
3/8	PL6H	1.56 (39.6)	0.38 (9.5)
9/16	PL9H	2.00 (50.8)	0.56 (14.2)

Collars and Glands

Collars



Tube OD in.	Ordering Number		
	Collar	Gland	Anti-vibration Gland
Medium Pressure: 20 000 psig (1378 bar)			
1/4	CL4M	GL4M	AV4M
3/8	CL6M	GL6M	AV6M
9/16	CL9M	GL9M	AV9M
3/4	CL12M	GL12M	AV12M
1	CL16M	GL16M	AV16M
1 1/2	CL24M	GL24M	AV24M
High Pressure: 60 000 psig (4134 bar)			
1/4	CL4H	GL4H	AV4H
3/8	CL6H	GL6H	AV6H
9/16	CL9H	GL9H	AV9H

Glands



Anti-vibration Glands

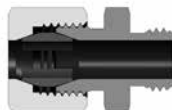

Medium-pressure anti-vibration glands include the anti-vibration gland nut, collet body and collet. Example: AV6M



High-pressure anti-vibration glands include the anti-vibration gland nut and collet. Example: AV6H

Safety Heads and Line Filters

Safety Heads

Angled Style

Flat Style

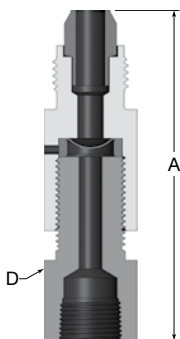
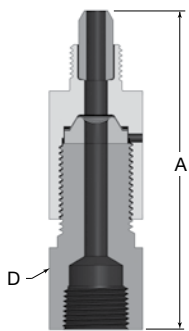

3/8 in. FNPT Outlet

3/8 in. FNPT Outlet

Tube OD in.	Basic Ordering Number	Dimensions, in. (mm)	
		A	D
Medium Pressure: 20 000 psig (1378 bar)			
1/4	SH4MM_20	3.42 (86.9)	1
3/8	SH6MM_20	3.42 (86.9)	1
9/16	SH9MM_20	3.56 (90.4)	1
High Pressure: 60 000 psig (4134 bar)			
1/4	SH4HM_60	3.24 (82.3)	1
3/8	SH6HM_60	3.59 (91.2)	1
9/16	SH9HM_60	3.72 (94.5)	1

To order, insert **A** for 1/4 in. angled style; insert **F** for 1/2 in. flat style.

Rupture discs are not included. See **Options and Accessories** for ordering information.

Line Filters

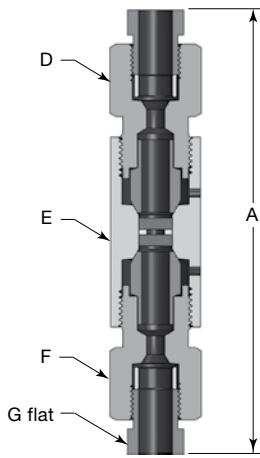

Tube OD in.	Basic Ordering Number	Dimensions, in. (mm)				
		A	D	E	F	G
Medium Pressure: 20 000 psig (1378 bar)						
1/4	LF4MF20-	4.96 (126)	7/8	1	7/8	1/2
3/8	LF6MF20-	5.15 (131)	7/8	1	7/8	5/8
9/16	LF9MF20-	5.22 (133)	1 1/8	1 3/8	1 1/8	7/8
3/4	LF12MF20-	7.84 (199)	1 3/8	1 3/4	1 3/8	13/16
1	LF16MF20-	9.14 (232)	1 3/4	1 3/4	1 3/4	1 3/8
High Pressure: 60 000 psig (4134 bar)						
1/4	LF4HF60-	5.22 (133)	7/8	1 3/8	7/8	5/8
3/8	LF6HF60-	5.97 (152)	1	1 3/8	1	13/16
9/16	LF9HF60-	7.97 (202)	1 3/8	1 1/2	1 3/8	1 3/16

Each line filter is designed with two filter elements—an upstream element and a downstream element. Filter elements are available in the following nominal pore sizes: 0.5, 2, 5, 10, 20, 40, and 100 µm. To order, add the filter element nominal pore sizes to the basic ordering number.

Example: For a line filter with an upstream, 40 µm filter element and a downstream, 20 µm filter elements, use ordering number: LF4MF20-40/20

Options and Accessories

Anti-vibration

For systems that experience shock or vibration, it is recommended to use anti-vibration components to help extend the life of the tubing connection.

Anti-vibration connection components are available for all cone and thread fittings. To order, add **-AV** to the ordering number.

Example: CN4MF20-**AV**

NACE-Compliant Fittings for Sour Gas Service

All IPT series cone and thread fittings are available for sour gas service. Materials are selected in accordance with NACE MR0175/ISO 15156.

- NACE cone and thread fittings are not supplied with collars and glands. Collar and glands must be ordered separately. See page 1071.

Technical Data

NACE Pressure Ratings at 70°F (20°C)

Medium Pressure	High Pressure
Working Pressure, psig (bar)	
10 000 (689)	30 000 (2067)

Temperature Rating

Temperatures up to 1000°F (537°C).

See Elevated Temperature Factors table on page 1068.

Materials of Construction

Annealed 316 stainless steel

Ordering Information

Select an ordering number from a **Dimensions** table and modify as shown. For ordering number ending in:

- 20, change 20 to **10-NACE**
- 60, change 60 to **30-NACE**

Example: Coupling—Ordering number: CN6MF20
NACE ordering number: CN6MF**10-NACE**

Collar—Ordering number: CL4M
NACE ordering number: CL4M-**NACE**

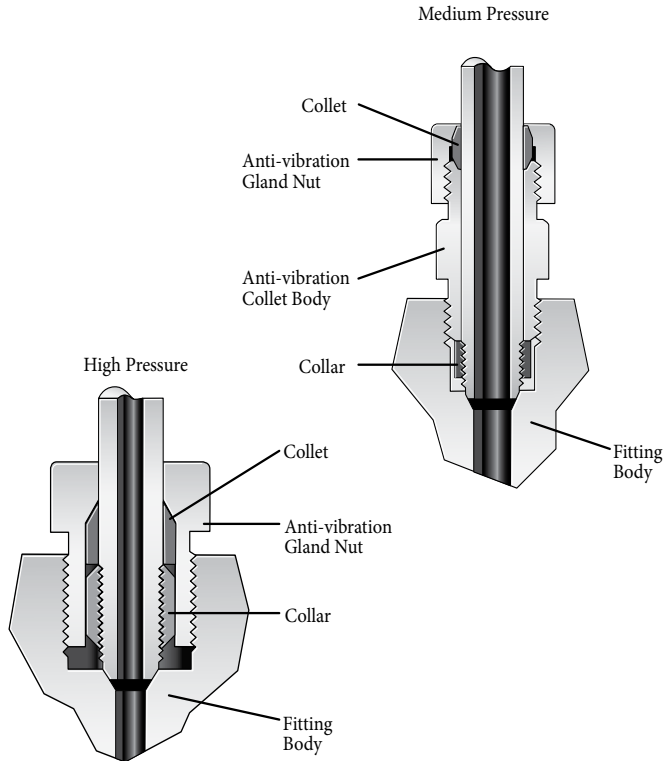

MEDIUM- AND HIGH-PRESSURE

Options and Accessories

Rupture Discs

- Shape: For angled (**A**) or flat (**F**) design safety heads
- Material: 316 stainless steel (**S**) or alloy 600 (**I**).
- Minimum order quantity = 3 pieces.
- Burst pressures: increments of 250 psig (17.2 bar) shown in *ksi* units.
 - Flat—500 to 10 000 psig (34.4 to 689 bar) (0.50 to 10.00 *ksi*)
 - Angled—1000 to 60 000 psig (68.9 to 4134 bar) (1.00 to 60.00 *ksi*)

To order, add the designators for shape, material, and burst pressure as shown below.

Typical ordering number:

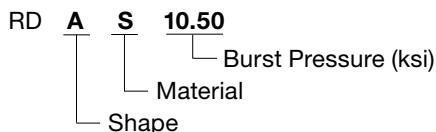

Goop Thread Lubricant

Always use a thread lubricant when assembling cone and thread fittings. See the Swagelok *Leak Detectors, Lubricants, and Sealants* catalog (MS-01-91), page 105 for more information.



Tubing Selection

IPT series cone and thread fittings can be used with 316 stainless steel IPT series coned and thread tubing. See the Tubing/Fitting Compatibility matrix on page 1105 for details.

Installation Instructions

Medium-Pressure Cone and Thread Fitting Assembly

These figures apply to 1/4, 3/8, 9/16, 3/4, 1 and 1 1/2 in. medium-pressure cone and thread fitting sizes.

Fig. 1

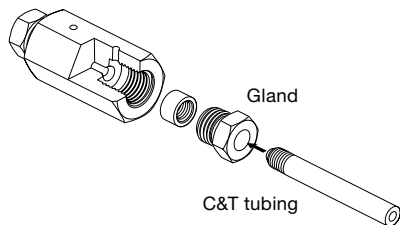

Fig. 2

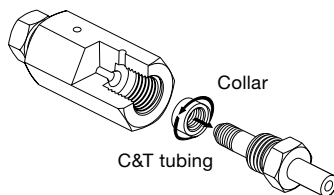

Fig. 3

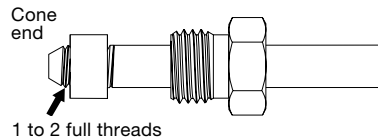

Fig. 4

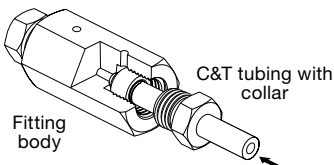

Fig. 5

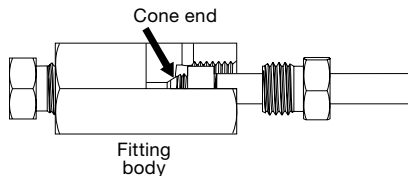
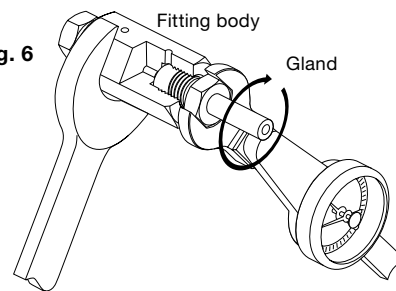

Fig. 6



Installation Instructions

High-Pressure Cone and Thread Fitting Assembly

These figures apply to 1/4, 3/8, and 9/16 in. high-pressure cone and thread fitting sizes.

Fig. 1

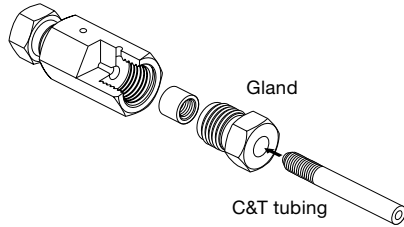

Fig. 2

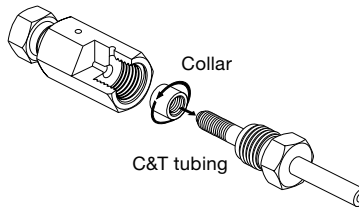

Fig. 3

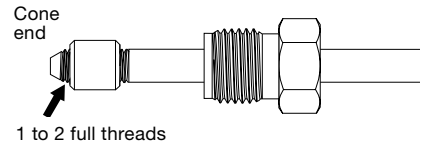

Fig. 4

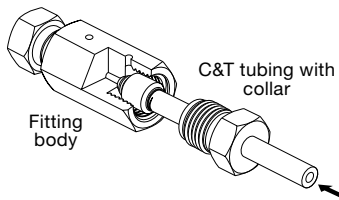

Fig. 5

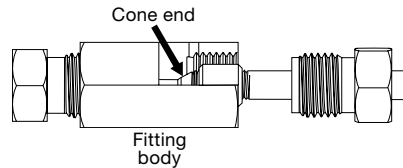
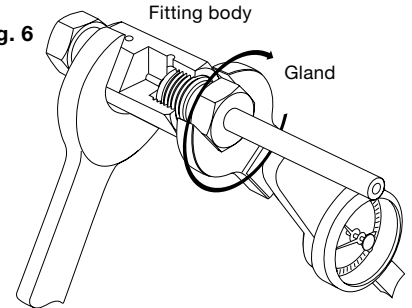

Fig. 6



1. Lubricate all male threads with an anti-seize lubricant, such as a Swagelok Goop product. Lubricate the cone end of the tubing with a system compatible lubricant. *Note: Anti-vibration collet bodies and gland nuts containing dry film lubricate applied at the factory do not need additional lubrication.*
2. For standard fittings, slide the C&T tubing into the gland (Fig. 1). For anti-vibration option (see diagram on page 1072), slide anti-vibration gland nut and collet onto tubing.

For medium-pressure anti-vibration fittings, slide the anti-vibration collet body onto tubing. *Note: Ensure proper orientation of collet body. Tapered face of collet body is to mate with collet.*

3. Thread the collar counter-clockwise (left-hand thread) onto the C&T tubing (Fig. 2).
4. Continue threading until 1 to 2 full threads are exposed at the cone end of the tubing. This will indicate proper position of the collar (Fig. 3).

5. Insert the C&T tubing with the collar into the fitting body (Fig. 4).
6. Make sure the cone end of the tubing rests firmly on the angled seat of the fitting body (Fig. 5).
7. For standard fittings thread the gland into the fitting body until finger tight. Hold the fitting body steady and tighten the gland (Fig. 6) to the required torque.

For high-pressure anti-vibration fittings, thread the gland nut into the fitting body until finger tight. Hold the body steady and tighten the gland to the required torque.

For medium-pressure anti-vibration fittings thread the anti-vibration collet body into the fitting body until finger tight. Tighten the anti-vibration collet body to specified torque. Then thread the anti-vibration gland nut onto the anti-vibration collet body until finger tight. Tighten the anti-vibration gland nut to the required torque. The collet will grip the tube when the anti-vibration gland nut is tightened.

Fitting Size in.	Required Torque ft-lb (N·m)	
	Medium-Pressure C&T Fitting	High-Pressure C&T Fitting
1/4	20 (27.2)	25 (33.9)
3/8	30 (40.7)	50 (67.8)
9/16	55 (74.6)	110 (150)
3/4	90 (123)	—
1	150 (204)	—
1 1/2	200 (271)	—

Adapters and Couplings— IPT Series

For Pressures up to 60 000 psig
(4134 bar)



- 316 stainless steel construction
- Temperatures up to 1000°F (537°C)
- Medium-pressure (MP) fittings
 - Size range—1/4 to 1 1/2 in.
 - Pressure rating—up to 20 000 psig (1378 bar)
- High-pressure (HP) fittings
 - Size range—1/4 to 9/16 in.
 - Pressure rating—up to 60 000 psig (4134 bar)

Contents

Features, 1076

Materials of Construction, 1076

Pressure Ratings, 1076

Cleaning and Packaging, 1076

Ordering Information, 1076

Male to Male

JIC (AN), 1076



NPT, 1077



Type M Hose, 1078



MP Cone and Thread, 1080



HP Cone and Thread, 1080



Female to Female

NPT, 1081



MP Cone and Thread, 1082



HP Cone and Thread, 1083



Male to Female

NPT, 1084



MP Cone and Thread, 1085



HP Cone and Thread, 1087



Options and Accessories

- NACE-Compliant Fittings, 1088
- Anti-vibration, 1088

Accessories

- Caps and Plugs for Type M Hose Connections, 1088

Replacement Parts

- Cone Plugs, 1088

Features

- End connections types include
 - JIC (AN)
 - NPT
 - Type M hose
 - Medium-pressure cone and thread (C&T)
 - High-pressure cone and thread (C&T).
- All female C&T adapters and couplings are supplied complete with glands and collars.
- All C&T adapters and couplings can be manufactured to meet NACE MR0175/ISO 15156.
- Anti-vibration connection components are available.
- C&T adapters and couplings are available in one- or two-piece designs.

Two-piece Design

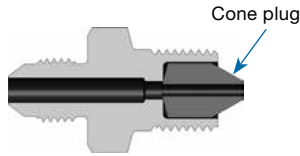

- Two-piece design is standard.
- Includes body and replaceable cone plug in case of galling.

One-piece Design

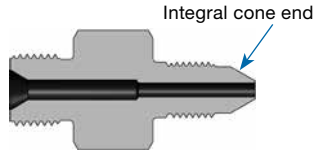

- One-piece design is optional.
- Features integral cone end on body for ease of assembly.

Pressure Ratings

Pressure ratings are dependent on the end connection with the lowest pressure rating. Working pressure determined based on ASME B31.3 Process Piping, Chapter IX High Pressure Piping unless otherwise specified.

- Maximum working pressure: Up to 60 000 psig (4134 bar).
- See ordering number tables for pressure ratings on specific adapters and couplings.

Elevated Temperature Factors

To determine allowable working pressure at elevated temperatures, multiply allowable working pressures shown in the ordering number tables by a factor shown in the table below.

Temperature		Factors	
°F	°C	Strain-Hardened 316 SS	Annealed 316 SS
-60 to 200	-51 to 93	1.00	1.00
400	204	0.93	0.96
600	315	0.93	0.85
800	426	0.92	0.79
1000	537	0.84	0.76

Materials of Construction

- Strain-hardened 316 stainless steel standard

Component	Material/ASTM Specification
<i>Body</i>	316 SS/A276, A479
Gland	316 SS/A276
Collar	316 SS/A276

Wetted components listed in *italics*.

Cleaning and Packaging

All cone and thread adapters and couplings are cleaned in accordance with Swagelok *Standard Cleaning and Packaging (SC-10)* (MS-06-62), page 1174.

Ordering Information

Ordering numbers shown are for the standard 2-piece design.

To order a one-piece cone and thread end connection, add **-S1** to the ordering number.

Exception: 1/4 in. cone and thread end connections are only available in the one-piece design, and do not require **-S1**.

Male-to-Male Adapters and Couplings

JIC (AN) to Cone and Thread

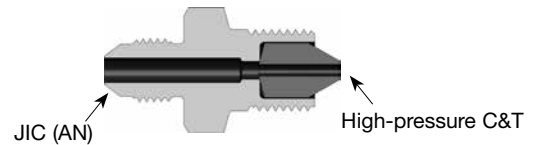

JIC (AN) (Thread Size) in.	HP C&T Size in.	Ordering Number	Pressure Ratings 316 SS ^① psig (bar)
1/4 (7/16-20)	1/4	CN4JM4HM10	10 000 (689)
	3/8	CN4JM6HM10	
	9/16	CN4JM9HM10	
3/8 (9/16-18)	1/4	CN6JM4HM8.2	8200 (564)
	3/8	CN6JM6HM8.2	
	9/16	CN6JM9HM8.2	
1/2 (3/4-16)	1/4	CN8JM4HM8.2	8200 (564)
	3/8	CN8JM6HM8.2	
	9/16	CN8JM9HM8.2	
3/4 (1 1/16-12)	1/4	CN12JM4HM7	7000 (482)
	3/8	CN12JM6HM7	
	9/16	CN12JM9HM7	
1 (1 5/16-12)	1/4	CN16JM4HM5	5000 (344)
	3/8	CN16JM6HM5	
	9/16	CN16JM9HM5	

① Working pressure determined based on ASME B31.3 Process Piping.

Male-to-Male Adapters and Couplings

Male NPT to Type M Hose

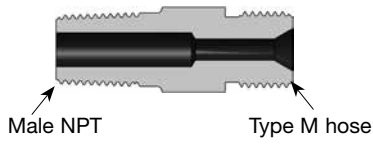

Male NPT to Male NPT



Male NPT Size in.	Type M Hose Thread Size in.	Ordering Number	Pressure Ratings 316 SS psig (bar)
1/4	9/16-18	CN4NM9RM15	15 000 (1034)
	3/4-16	CN4NM12RM15	
	1-12	CN4NM16RM15	
3/8	9/16-18	CN6NM9RM15	15 000 (1034)
	3/4-16	CN6NM12RM15	
	1-12	CN6NM16RM15	
1/2	9/16-18	CN8NM9RM15	15 000 (1034)
	3/4-16	CN8NM12RM15	
	1-12	CN8NM16RM15	
	1 5/16-12	CN8NM21RM15	
3/4	9/16-18	CN12NM9RM10	10 000 (689)
	3/4-16	CN12NM12RM10	
	1-12	CN12NM16RM10	
	1 5/16-12	CN12NM21RM10	
1	9/16-18	CN16NM9RM10	10 000 (689)
	3/4-16	CN16NM12RM10	
	1-12	CN16NM16RM10	
	1 5/16-12	CN16NM21RM10	

Male NPT Size in.	Male NPT Size in.	Basic Ordering Number	Pressure Ratings 316 SS psig (bar)
1/4	1/4	CN4NM	15 000 (1034)
	3/8	CN4NF6NM	
	1/2	CN4NF8NM	
	3/4	CN4NF12NM	10 000 (689)
	1	CN4NF16NM	
3/8	3/8	CN6NM	15 000 (1034)
	1/2	CN6NF8NM	
	3/4	CN6NF12NM	10 000 (689)
	1	CN6NF16NM	
1/2	1/2	CN8NM	15 000 (1034)
	3/4	CN8NF12NM	
	1	CN8NF16NM	10 000 (689)
3/4	3/4	CN12NM	10 000 (689)
	1	CN12NF16NM	
1	1	CN16NM	10 000 (689)

Male-to-Male Adapters and Couplings

Male NPT to Medium-Pressure Cone and Thread

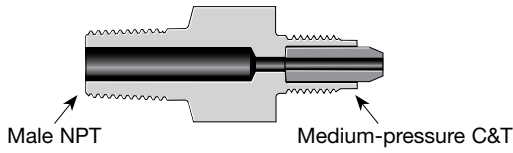

Male NPT Size in.	MP C&T Size in.	Ordering Number	Pressure Ratings 316 SS psig (bar)
1/8	1/4	CN2NM4MM15	15 000 (1034)
	3/8	CN2NM6MM15	
	9/16	CN2NM9MM15	
	3/4	CN2NM12MM15	
	1	CN2NM16MM15	
1/4	1/4	CN4NM4MM15	15 000 (1034)
	3/8	CN4NM6MM15	
	9/16	CN4NM9MM15	
	3/4	CN4NM12MM15	
	1	CN4NM16MM15	
3/8	1/4	CN6NM4MM15	15 000 (1034)
	3/8	CN6NM6MM15	
	9/16	CN6NM9MM15	
	3/4	CN6NM12MM15	
	1	CN6NM16MM15	
1/2	1/4	CN8NM4MM15	15 000 (1034)
	3/8	CN8NM6MM15	
	9/16	CN8NM9MM15	
	3/4	CN8NM12MM15	
	1	CN8NM16MM15	
3/4	1/4	CN12NM4MM10	10 000 (689)
	3/8	CN12NM6MM10	
	9/16	CN12NM9MM10	
	3/4	CN12NM12MM10	
	1	CN12NM16MM10	
1	1/4	CN16NM4MM10	10 000 (689)
	3/8	CN16NM6MM10	
	9/16	CN16NM9MM10	
	3/4	CN16NM12MM10	
	1	CN16NM16MM10	

Type M Hose to Type M Hose

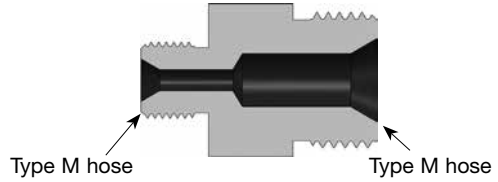

Type M Hose Thread Size in.	Type M Hose Thread Size in.	Ordering Number	Pressure Ratings 316 SS psig (bar)
9/16-18	9/16-18	CN9RM40	40 000 (2756)
	3/4-16	CN9RM12RM30	30 000 (2067)
	1-12	CN9RM16RM30	30 000 (2067)
3/4-16	3/4-16	CN12RM30	30 000 (2067)
	1-12	CN12RM16RM30	
1-12	1-12	CN16RM30	30 000 (2067)
	1 5/16-12	CN16RM21RM20	20 000 (1378)
1 5/16-12	1 5/16-12	CN21RM20	20 000 (1378)

Male NPT to High-Pressure Cone and Thread

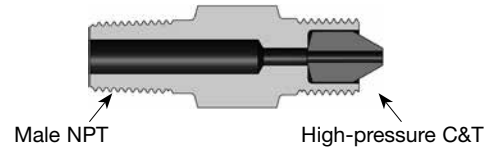

Male NPT Size in.	HP C&T Size in.	Ordering Number	Pressure Ratings 316 SS psig (bar)
1/8	1/4	CN2NM4HM15	15 000 (1034)
	3/8	CN2NM6HM15	
	9/16	CN2NM9HM15	
1/4	1/4	CN4NM4HM15	15 000 (1034)
	3/8	CN4NM6HM15	
	9/16	CN4NM9HM15	
3/8	1/4	CN6NM4HM15	15 000 (1034)
	3/8	CN6NM6HM15	
	9/16	CN6NM9HM15	
1/2	1/4	CN8NM4HM15	15 000 (1034)
	3/8	CN8NM6HM15	
	9/16	CN8NM9HM15	
3/4	1/4	CN12NM4HM10	10 000 (689)
	3/8	CN12NM6HM10	
	9/16	CN12NM9HM10	
1	1/4	CN16NM4HM10	10 000 (689)
	3/8	CN16NM6HM10	
	9/16	CN16NM9HM10	

Male-to-Male Adapters and Couplings

Type M Hose to Medium-Pressure Cone and Thread

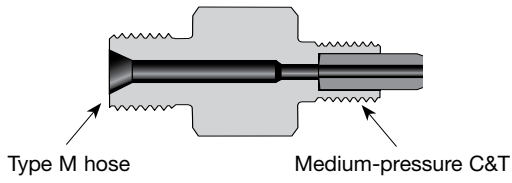

Type M Hose to High-Pressure Cone and Thread

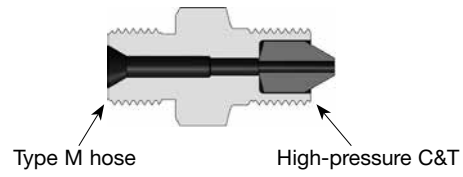

Type M Hose Thread Size in.	MP C&T Size in.	Ordering Number	Pressure Ratings 316 SS psig (bar)
9/16-18	1/4	CN4MM9RM20	20 000 (1378)
	3/8	CN6MM9RM20	
	9/16	CN9MM9RM20	
	3/4	CN12MM9RM20	
	1	CN16MM9RM20	
3/4-16	1/4	CN4MM12RM20	20 000 (1378)
	3/8	CN6MM12RM20	
	9/16	CN9MM12RM20	
	3/4	CN12MM12RM20	
	1	CN16MM12RM20	
1-12	1/4	CN4MM16RM20	20 000 (1378)
	3/8	CN6MM16RM20	
	9/16	CN9MM16RM20	
	3/4	CN12MM16RM20	
	1	CN16MM16RM20	
1 5/16-12	9/16	CN9MM21RM20	20 000 (1378)
	3/4	CN12MM21RM20	
	1	CN16MM21RM20	

Type M Hose Thread Size in.	HP C&T Size in.	Ordering Number	Pressure Ratings 316 SS psig (bar)
9/16-18	1/4	CN9RM4HM40	40 000 (2756)
	3/8	CN9RM6HM40	
	9/16	CN9RM9HM40	
3/4-16	1/4	CN12RM4HM30	30 000 (2067)
	3/8	CN12RM6HM30	
	9/16	CN12RM9HM30	
1-12	3/8	CN16RM6HM30	30 000 (2067)
	9/16	CN16RM9HM30	
1 5/16-12	9/16	CN21RM9HM50	50 000 (3445)

Male-to-Male Adapters and Couplings

Medium-Pressure Cone and Thread to Medium-Pressure Cone and Thread

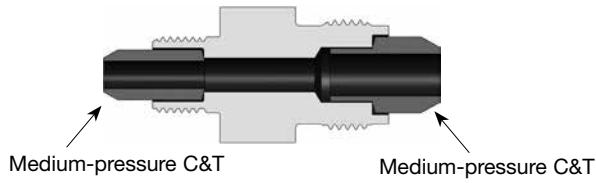

MP C&T Size in.	MP C&T Size in.	Ordering Number	Pressure Ratings 316 SS psig (bar)
1/4	1/4	CN4MM20	20 000 (1378)
	3/8	CN4MM6MM20	
	9/16	CN4MM9MM20	
	3/4	CN4MM12MM20	
	1	CN4MM16MM20	
3/8	3/8	CN6MM20	20 000 (1378)
	9/16	CN6MM9MM20	
	3/4	CN6MM12MM20	
	1	CN6MM16MM20	
9/16	9/16	CN9MM20	20 000 (1378)
	3/4	CN9MM12MM20	
	1	CN9MM16MM20	
3/4	3/4	CN12MM20	20 000 (1378)
	1	CN12MM16MM20	
1	1	CN16MM20	20 000 (1378)
1 1/2	1 1/2	CN24MM15	15 000 (1034)

Medium-Pressure Cone and Thread to High-Pressure Cone and Thread

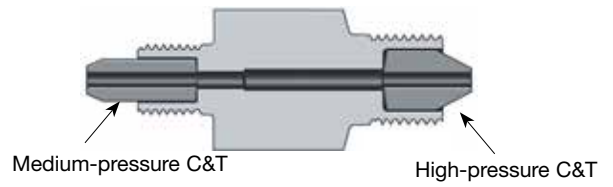

MP C&T Size in.	HP C&T Size in.	Ordering Number	Pressure Ratings 316 SS psig (bar)
1/4	1/4	CN4MM4HM20	20 000 (1378)
	3/8	CN4MM6HM20	
	9/16	CN4MM9HM20	
3/8	1/4	CN6MM4HM20	20 000 (1378)
	3/8	CN6MM6HM20	
9/16	9/16	CN6MM9HM20	20 000 (1378)
	1/4	CN9MM4HM20	
3/4	3/8	CN9MM6HM20	20 000 (1378)
	9/16	CN9MM9HM20	
	1/4	CN12MM4HM20	
1	3/8	CN12MM6HM20	20 000 (1378)
	9/16	CN12MM9HM20	
	1/4	CN16MM4HM20	
1	3/8	CN16MM6HM20	20 000 (1378)
	9/16	CN16MM9HM20	

High-Pressure Cone and Thread to High-Pressure Cone and Thread

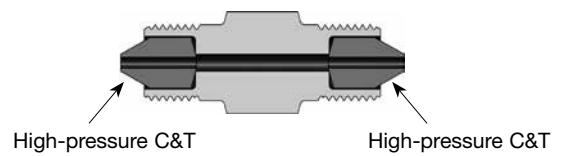

HP C&T Size in.	HP C&T Size in.	Ordering Number	Pressure Ratings 316 SS psig (bar)
1/4	1/4	CN4HM60	60 000 (4134)
	3/8	CN4HM6HM60	
	9/16	CN4HM9HM60	
3/8	3/8	CN6HM60	60 000 (4134)
	9/16	CN6HM9HM60	
9/16	9/16	CN9HM60	60 000 (4134)

Female-to-Female Adapters and Couplings

Female NPT to Female NPT

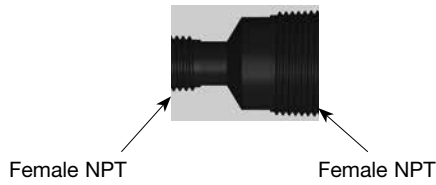

Female NPT to Medium-Pressure Cone and Thread

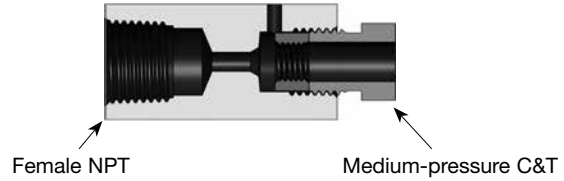

Female NPT Size in.	Female NPT Size in.	Ordering Number	Pressure Ratings 316 SS psig (bar)
1/4	1/4	CN4NF15	15 000 (1034)
	3/8	CN4NF6NF15	
	1/2	CN4NF8NF15	
	3/4	CN4NF12NF10	10 000 (689)
	1	CN4NF16NF10	
3/8	3/8	CN6NF15	15 000 (1034)
	1/2	CN6NF8NF15	
	3/4	CN6NF12NF10	10 000 (689)
	1	CN6NF16NF10	
1/2	1/2	CN8NF15	15 000 (1034)
	3/4	CN8NF12NF10	10 000 (689)
	1	CN8NF16NF10	10 000 (689)
3/4	3/4	CN12NF10	10 000 (689)
	1	CN12NF16NF10	
1	1	CN16NF10	10 000 (689)

Female NPT Size in.	MP C&T Size in.	Ordering Number	Pressure Ratings 316 SS psig (bar)
1/4	1/4	CN4NF4MF15	15 000 (1034)
	3/8	CN4NF6MF15	
	9/16	CN4NF9MF15	
	3/4	CN4NF12MF15	
	1	CN4NF16MF15	
3/8	1/4	CN6NF4MF15	15 000 (1034)
	3/8	CN6NF6MF15	
	9/16	CN6NF9MF15	
	3/4	CN6NF12MF15	
1/2	1/4	CN8NF4MF15	15 000 (1034)
	3/8	CN8NF6MF15	
	9/16	CN8NF9MF15	
	3/4	CN8NF12MF15	
	1	CN8NF16MF15	
3/4	1/4	CN12NF4MF10	10 000 (689)
	3/8	CN12NF6MF10	
	9/16	CN12NF9MF10	
	3/4	CN12NF12MF10	
	1	CN12NF16MF10	
1	1/4	CN16NF4MF10	10 000 (689)
	3/8	CN16NF6MF10	
	9/16	CN16NF9MF10	
	3/4	CN16NF12MF10	
	1	CN16NF16MF10	

Female-to-Female Adapters and Couplings

Female NPT to High-Pressure Cone and Thread

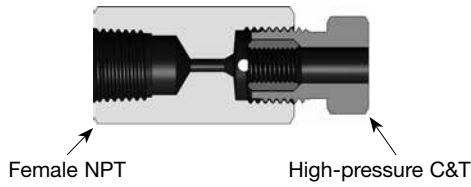

Female NPT Size in.	HP C&T Size in.	Ordering Number	Pressure Ratings 316 SS psig (bar)
1/4	1/4	CN4NF4HF15	15 000 (1034)
	3/8	CN4NF6HF15	
	9/16	CN4NF9HF15	
3/8	1/4	CN6NF4HF15	15 000 (1034)
	3/8	CN6NF6HF15	
	9/16	CN6NF9HF15	
1/2	1/4	CN8NF4HF15	15 000 (1034)
	3/8	CN8NF6HF15	
	9/16	CN8NF9HF15	
3/4	1/4	CN12NF4HF10	10 000 (689)
	3/8	CN12NF6HF10	
	9/16	CN12NF9HF10	
1	1/4	CN16NF4HF10	10 000 (689)
	3/8	CN16NF6HF10	
	9/16	CN16NF9HF10	

Medium-Pressure Cone and Thread to Medium-Pressure Cone and Thread

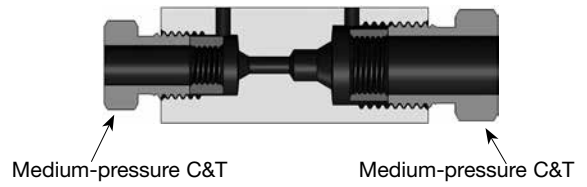

MP C&T Size in.	MP C&T Size in.	Ordering Number	Pressure Ratings 316 SS psig (bar)
1/4	1/4	CN4MF20	20 000 (1378)
	3/8	CN4MF6MF20	
	9/16	CN4MF9MF20	
	3/4	CN4MF12MF20	
	1	CN4MF16MF20	
3/8	3/8	CN6MF20	20 000 (1378)
	9/16	CN6MF9MF20	
	3/4	CN6MF12MF20	
	1	CN6MF16MF20	
9/16	9/16	CN9MF20	20 000 (1378)
	3/4	CN9MF12MF20	
	1	CN9MF16MF20	
3/4	3/4	CN12MF20	20 000 (1378)
	1	CN12MF16MF20	
1	1	CN16MF20	

Female-to-Female Adapters and Couplings

Medium-Pressure Cone and Thread to High-Pressure Cone and Thread

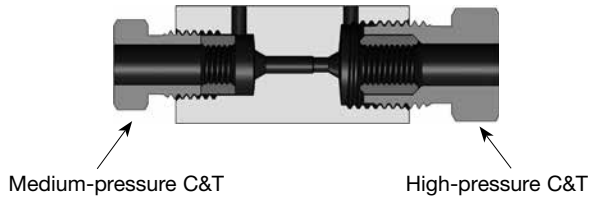

High-Pressure Cone and Thread to High-Pressure Cone and Thread

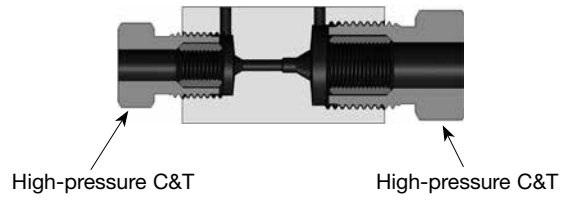

MP C&T Size in.	HP C&T Size in.	Ordering Number	Pressure Ratings 316 SS psig (bar)
1/4	1/4	CN4MF4HF20	20 000 (1378)
	3/8	CN4MF6HF20	
	9/16	CN4MF9HF20	
3/8	1/4	CN6MF4HF20	20 000 (1378)
	3/8	CN6MF6HF20	
	9/16	CN6MF9HF20	
9/16	1/4	CN9MF4HF20	20 000 (1378)
	3/8	CN9MF6HF20	
	9/16	CN9MF9HF20	
3/4	1/4	CN12MF4HF20	20 000 (1378)
	3/8	CN12MF6HF20	
	9/16	CN12MF9HF20	
1	1/4	CN16MF4HF20	20 000 (1378)
	3/8	CN16MF6HF20	
	9/16	CN16MF9HF20	

HP C&T Size in.	HP C&T Size in.	Ordering Number	Pressure Ratings 316 SS psig (bar)
1/4	1/4	CN4HF60	60 000 (4134)
	3/8	CN4HF6HF60	
	9/16	CN4HF9HF60	
3/8	1/4	CN4HF6HF60	60 000 (4134)
	3/8	CN6HF60	
	9/16	CN6HF9HF60	
9/16	1/4	CN4HF9HF60	60 000 (4134)
	3/8	CN6HF9HF60	
	9/16	CN9HF60	

Male-to-Female Adapters and Couplings

Male NPT to Female NPT



Male NPT Size in.	Female NPT Size in.	Ordering Number	Pressure Ratings 316 SS psig (bar)
1/4	1/4	CN4NM4NF15	15 000 (1034)
	3/8	CN4NM6NF15	
	1/2	CN4NM8NF15	
	3/4	CN4NM12NF10	10 000 (689)
	1	CN4NM16NF10	
3/8	1/4	CN6NM4NF15	15 000 (1034)
	3/8	CN6NM6NF15	
	1/2	CN6NM8NF15	
	3/4	CN6NM12NF10	10 000 (689)
	1	CN6NM16NF10	
1/2	1/4	CN8NM4NF15	15 000 (1034)
	3/8	CN8NM6NF15	
	1/2	CN8NM8NF15	
	3/4	CN8NM12NF10	10 000 (689)
	1	CN8NM16NF10	
3/4	1/4	CN12NM4NF10	10 000 (689)
	3/8	CN12NM6NF10	
	1/2	CN12NM8NF10	
	3/4	CN12NM12NF10	
	1	CN12NM16NF10	
1	1/4	CN16NM4NF10	10 000 (689)
	3/8	CN16NM6NF10	
	1/2	CN16NM8NF10	
	3/4	CN16NM12NF10	
	1	CN16NM16NF10	

Male NPT to Medium-Pressure Cone and Thread

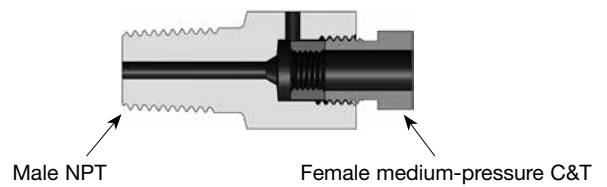

Male NPT Size in.	Female MP C&T Size in.	Ordering Number	Pressure Ratings 316 SS psig (bar)
1/4	1/4	CN4NM4MF15	15 000 (1034)
	3/8	CN4NM6MF15	
	9/16	CN4NM9MF15	
	3/4	CN4NM12MF15	
	1	CN4NM16MF15	
3/8	1/4	CN6NM4MF15	15 000 (1034)
	3/8	CN6NM6MF15	
	9/16	CN6NM9MF15	
	3/4	CN6NM12MF15	
	1	CN6NM16MF15	
1/2	1/4	CN8NM4MF15	15 000 (1034)
	3/8	CN8NM6MF15	
	9/16	CN8NM9MF15	
	3/4	CN8NM12MF15	
	1	CN8NM16MF15	
3/4	1/4	CN12NM4MF10	10 000 (689)
	3/8	CN12NM6MF10	
	9/16	CN12NM9MF10	
	3/4	CN12NM12MF10	
	1	CN12NM16MF10	
1	1/4	CN16NM4MF10	10 000 (689)
	3/8	CN16NM6MF10	
	9/16	CN16NM9MF10	
	3/4	CN16NM12MF10	
	1	CN16NM16MF10	

Male-to-Female Adapters and Couplings

Male NPT to High-Pressure Cone and Thread

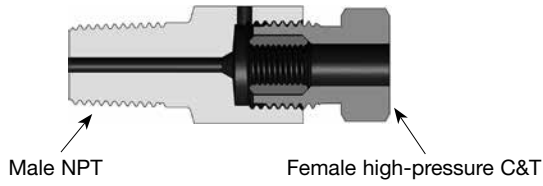

Medium-Pressure Cone and Thread to Female NPT

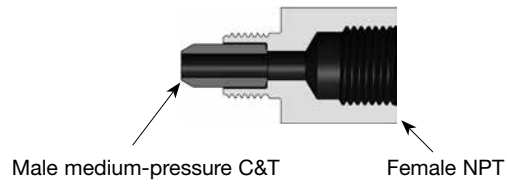

Male NPT Size in.	Female HP C&T Size in.	Ordering Number	Pressure Ratings 316 SS psig (bar)
1/4	1/4	CN4NM4HF15	15 000 (1034)
	3/8	CN4NM6HF15	
	9/16	CN4NM9HF15	
3/8	1/4	CN6NM4HF15	15 000 (1034)
	3/8	CN6NM6HF15	
	9/16	CN6NM9HF15	
1/2	1/4	CN8NM4HF15	15 000 (1034)
	3/8	CN8NM6HF15	
	9/16	CN8NM9HF15	
3/4	1/4	CN12NM4HF10	10 000 (689)
	3/8	CN12NM6HF10	
	9/16	CN12NM9HF10	
1	1/4	CN16NM4HF10	10 000 (689)
	3/8	CN16NM6HF10	
	9/16	CN16NM9HF10	

Male MP C&T Size in.	Female NPT Size in.	Ordering Number	Pressure Ratings 316 SS psig (bar)
1/4	1/4	CN4MM4NF15	15 000 (1034)
	3/8	CN4MM6NF15	
	1/2	CN4MM8NF15	
	3/4	CN4MM12NF10	10 000 (689)
	1	CN4MM16NF10	
3/8	1/4	CN6MM4NF15	15 000 (1034)
	3/8	CN6MM6NF15	
	1/2	CN6MM8NF15	
	3/4	CN6MM12NF10	10 000 (689)
	1	CN6MM16NF10	
9/16	1/4	CN9MM4NF15	15 000 (1034)
	3/8	CN9MM6NF15	
	1/2	CN9MM8NF15	
	3/4	CN9MM12NF10	10 000 (689)
	1	CN9MM16NF10	
3/4	1/4	CN12MM4NF15	15 000 (1034)
	3/8	CN12MM6NF15	
	1/2	CN12MM8NF15	
	3/4	CN12MM12NF10	10 000 (689)
	1	CN12MM16NF10	
1	1/4	CN16MM4NF15	15 000 (1034)
	3/8	CN16MM6NF15	
	1/2	CN16MM8NF15	
	3/4	CN16MM12NF10	10 000 (689)
	1	CN16MM16NF10	

Male-to-Female Adapters and Couplings

Medium-Pressure Cone and Thread to Medium-Pressure Cone and Thread

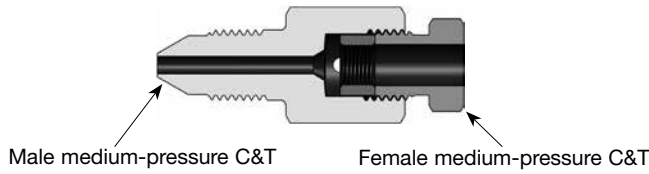

Medium-Pressure Cone and Thread to High-Pressure Cone and Thread

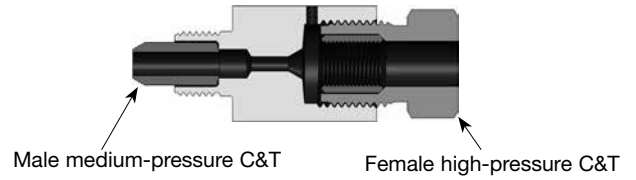

Male MP C&T Size in.	Female MP C&T Size in.	Ordering Number	Pressure Ratings 316 SS psig (bar)
1/4	1/4	CN4MM4MF20	20 000 (1378)
	3/8	CN4MM6MF20	
	9/16	CN4MM9MF20	
	3/4	CN4MM12MF20	
	1	CN4MM16MF20	
3/8	1/4	CN6MM4MF20	20 000 (1378)
	3/8	CN6MM6MF20	
	9/16	CN6MM9MF20	
	3/4	CN6MM12MF20	
9/16	1/4	CN9MM4MF20	20 000 (1378)
	3/8	CN9MM6MF20	
	9/16	CN9MM9MF20	
	3/4	CN9MM12MF20	
3/4	1/4	CN12MM4MF20	20 000 (1378)
	3/8	CN12MM6MF20	
	9/16	CN12MM9MF20	
	3/4	CN12MM12MF20	
	1	CN12MM16MF20	
1	1/4	CN16MM4MF20	20 000 (1378)
	3/8	CN16MM6MF20	
	9/16	CN16MM9MF20	
	3/4	CN16MM12MF20	
1 1/2	1/4	CN24MM4MF15	15 000 (1034)
	9/16	CN24MM9MF15	
	1	CN24MM16MF15	

Male MP C&T Size in.	Female HP C&T Size in.	Ordering Number	Pressure Ratings 316 SS psig (bar)
1/4	1/4	CN4MM4HF20	20 000 (1378)
	3/8	CN4MM6HF20	
	9/16	CN4MM9HF20	
3/8	1/4	CN6MM4HF20	20 000 (1378)
	3/8	CN6MM6HF20	
	9/16	CN6MM9HF20	
9/16	1/4	CN9MM4HF20	20 000 (1378)
	3/8	CN9MM6HF20	
	9/16	CN9MM9HF20	
3/4	1/4	CN12MM4HF20	20 000 (1378)
	3/8	CN12MM6HF20	
	9/16	CN12MM9HF20	
1	1/4	CN16MM4HF20	20 000 (1378)
	3/8	CN16MM6HF20	
	9/16	CN16MM9HF20	

Male-to-Female Adapters and Couplings

High-Pressure Cone and Thread to Female NPT

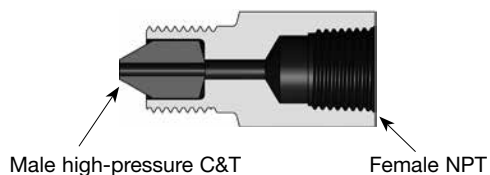

Male HP C&T Size in.	Female NPT Size in.	Ordering Number	Pressure Ratings 316 SS psig (bar)
1/4	1/4	CN4HM4NF15	15 000 (1378)
	3/8	CN4HM6NF15	
	1/2	CN4HM8NF15	
	3/4	CN4HM12NF10	10 000 (689)
	1	CN4HM16NF10	
3/8	1/4	CN6HM4NF15	15 000 (1378)
	3/8	CN6HM6NF15	
	1/2	CN6HM8NF15	
	3/4	CN6HM12NF10	10 000 (689)
	1	CN6HM16NF10	
9/16	1/4	CN9HM4NF15	15 000 (1378)
	3/8	CN9HM6NF15	
	1/2	CN9HM8NF15	
	3/4	CN9HM12NF10	10 000 (689)
	1	CN9HM16NF10	

High-Pressure Cone and Thread to Medium-Pressure Cone and Thread

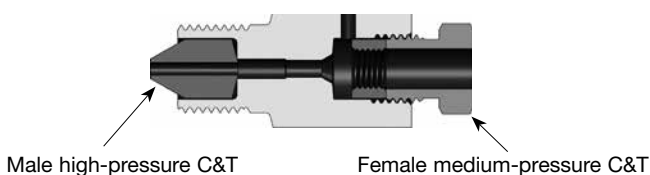

Male HP C&T Size in.	Female MP C&T Size in.	Ordering Number	Pressure Ratings 316 SS psig (bar)
1/4	1/4	CN4HM4MF20	20 000 (1378)
	3/8	CN4HM6MF20	
	9/16	CN4HM9MF20	
	3/4	CN4HM12MF20	
	1	CN4HM16MF20	
3/8	1/4	CN6HM4MF20	20 000 (1378)
	3/8	CN6HM6MF20	
	9/16	CN6HM9MF20	
	3/4	CN6HM12MF20	
	1	CN6HM16MF20	
9/16	1/4	CN9HM4MF20	20 000 (1378)
	3/8	CN9HM6MF20	
	9/16	CN9HM9MF20	
	3/4	CN9HM12MF20	
	1	CN9HM16MF20	

High-Pressure Cone and Thread to High-Pressure Cone and Thread

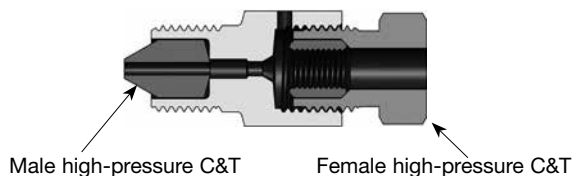

Male HP C&T Size in.	Female HP C&T Size in.	Ordering Number	Pressure Ratings 316 SS psig (bar)
1/4	1/4	CN4HM4HF60	60 000 (4134)
	3/8	CN4HM6HF60	
	9/16	CN4HM9HF60	
3/8	1/4	CN6HM4HF60	60 000 (4134)
	3/8	CN6HM6HF60	
	9/16	CN6HM9HF60	
9/16	1/4	CN9HM4HF60	60 000 (4134)
	3/8	CN9HM6HF60	
	9/16	CN9HM9HF60	

MEDIUM- AND HIGH-PRESSURE

Options

NACE-Compliant Adapters for Sour Gas Service

All IPT series cone and thread adapters and couplings are available for sour gas service except JIC (AN) ended fittings. Materials are selected in accordance with NACE MR0175/ISO 15156.

- NACE cone and thread adapters and couplings are not supplied with collars and glands. Collar and glands must be ordered separately. See page 1071.

Technical Data

NACE Pressure Ratings at 70°F (20°C)

Standard pressure ratings for each adapter and coupling are shown in the ordering number tables. For fittings rated to 10 000 (689), 20 000 (1378), and 60 000 (4134) psig (bar), the comparable NACE pressure ratings are shown in the table below. For fittings with ratings not included in the table, contact your authorized Swagelok representative for information.

Adapters and Couplings	
Standard Pressure Rating	NACE Pressure Rating
Working Pressure, psig (bar)	
10 000 (689)	5 000 (344)
20 000 (1378)	10 000 (689)
60 000 (4 134)	30 000 (2 067)

Temperature Rating

Temperatures up 1000°F (537°C).

See Elevated Temperature Factors table on page 1068.

Materials of Construction

Annealed 316 stainless steel

Ordering Information

Select an ordering number from the **Ordering Information** tables and modify as follows. For ordering numbers ending in

- 10, change 10 to **5-NACE**
- 20, change 20 to **10-NACE**
- 60, change 60 to **30-NACE**

Example: Standard ordering number: CN9MM9HM20

NACE ordering number: CN9MM9HM**10-NACE**

Anti-vibration

Anti-vibration connection components are available for all cone and thread adapters and couplings. To order, add **-AV** to the ordering number.

Example: CN4NM4MM15-**AV**

Accessories

Caps and Plugs for Type M Hose Connections

Cap and plugs for Type M hose end connections are available. Select order number below.

Type M Hose Thread Size	Ordering Number	
	Cap	Plug
9/16-18	CA9R40	PL9R
3/4-16	CA12R30	PL12R
1-12	CA16R30	PL16R
1 5/16-12	CA21R20	PL21R

Replacement Parts

Cone Plugs

Replacement cone plugs for 2-piece cone and thread adapters are available. Select order number below.

C&T Size in.	Ordering Number	
	Medium Pressure	High Pressure
1/4	—	IP40171-04
3/8	IP40399-04	IP40169-04
9/16	IP40172-04	IP40170-04
3/4	IP40404-04	—
1	IP40405-04	—

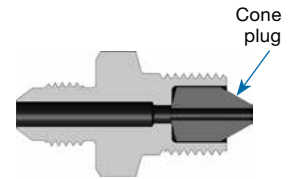

Tubing Selection

IPT series cone and thread adapters and couplings can be used with 316 stainless steel IPT series coned and thread tubing. See the Tubing/Fitting Compatibility matrix on page 1105 for details.

Coning and Threading Tool —IPT Series

For Pressures up to 60 000 psig
(4134 bar)



- Precision quality coning and threading tools for tubing sizes through 9/16 in. OD
- Manufactured from tool grade materials for long life
- Tool includes everything needed to prepare both medium- and high-pressure tubing in 1/4, 3/8 and 9/16 in. sizes with the exception of coning blade and threading die.

Features

- All tools are designed with interchangeable blades, bushings, and dies.
- Tools are easily adaptable for use with a power hand drill.
- Tool guides on the outside diameter of the tubing, eliminating misalignment issues that adversely affect quality.
- Lightweight tube vise securely holds the tubing during both coning and threading operations, preventing marring and collapse of the tubing.
- Tube vise eliminates the need for soft jaws in vise.
- Custom coning tool gauge allows for fast setup.
- Kit and components are compatible with the first IPT series CTK469 kit.

Ordering Information

Coning and Threading Tool

- To order the coning and threading tool, use ordering number **MS-CTK469**. Tooling kit sold separately.
- Threading dies and coning blades are sold separately. The tooling kit includes one coning blade and one threading die. Threading dies and coning blades are also sold separately. See table for ordering numbers.

Individual Components

Tubing Size in.	Ordering Number					
	Medium Pressure			High Pressure		
	Coning Blade	Threading Die	Tooling Kit ^①	Coning Blade	Threading Die	Tooling Kit ^①
1/4	BL4M	MS-DT4	MS-TK-4M	BL4H	MS-DT4	MS-TK-4H
3/8	BL6M	MS-DT6	MS-TK-6M	BL6H	MS-DT6	MS-TK-6H
9/16	BL9M	MS-DT9	MS-TK-9M	BL9H	MS-DT9	MS-TK-9H

① Tooling kit includes one tooling coning blade and threading die.

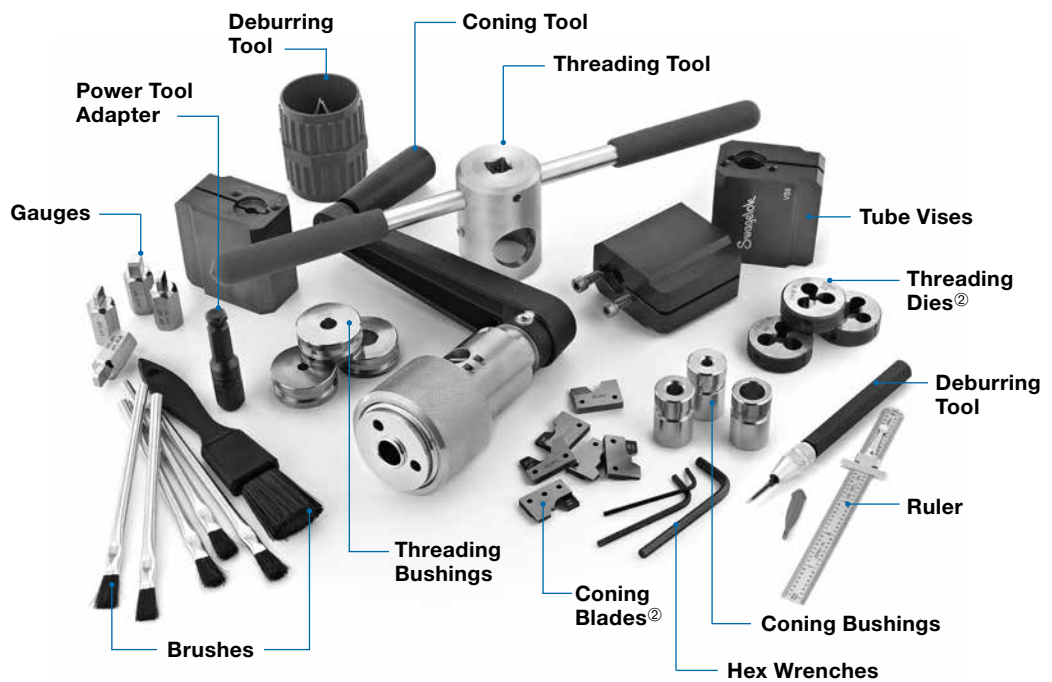

② Sold separately. See **Individual Components** table above.

Medium-Pressure Pipe Fittings—IPT Series

For Pressures up to 15 000 psig (1034 bar)

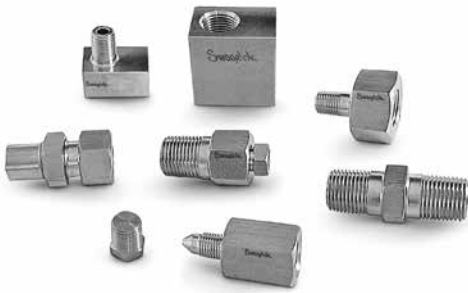

- 316 stainless steel construction
- Working pressure up to 15 000 psig (1034 bar)
- Temperatures up 1000°F (537°C)
- Size range—1/8 to 1 in.

Contents

- Features, 1091**
- Materials of Construction, 1091**
- Thread Specifications, 1091**
- Pressure Ratings, 1091**
- Temperature Ratings, 1091**
- Cleaning and Packaging, 1091**
- Ordering Information and Dimensions, 1092**

Couplings, 1092



Elbows, 1092



Tees, 1093



Crosses, 1094



Bulkheads, 1094



Caps and Plugs, 1094



Safety Heads, 1094



Line Filters, 1095



Accessories

- NACE-Compliant Fittings, 1095
- Rupture Disc, 1095
- Pipe Thread Sealant, 1095



Medium-Pressure Pipe Fittings

Straight fittings are manufactured from quality hex bar stock for strength.

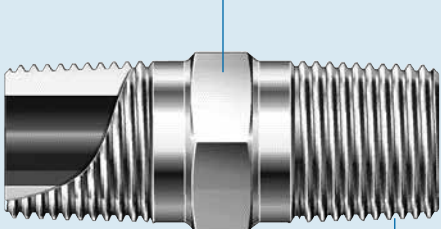

NPT threads are based on requirements of ASME B1.20.1 and SAE AS71051.

Marking identifies material, heat code for material traceability, and ISO end connection.

Shaped fittings are manufactured from quality square bar stock.

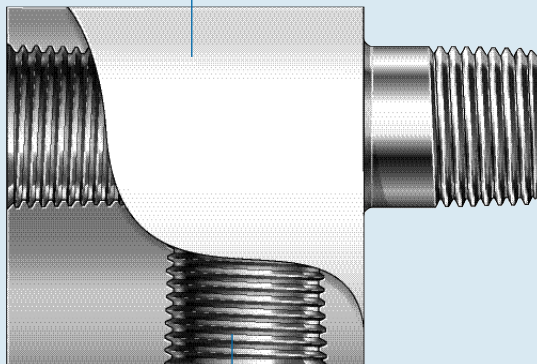

Smooth thread flanks provide optimum sealing and minimize galling.

Features

- Every fitting is marked for easy source tracing.
- Male threads are capped during packaging for protection.
- All IPT pipe fittings can be manufactured to meet NACE MR0175/ISO 15156.

Materials of Construction

- Strain-hardened 316 stainless steel standard

Material	Specification
316 stainless steel	ASME SA479, ASTM A276

Thread Specifications

Thread Type	Specification
NPT	ASME B1.20.1, SAE AS71051

Pressure Ratings

Working pressure determined based on ASME B31.3 Process Piping, Chapter IX High Pressure Piping, at ambient temperature.

Material	NPT Size	Pressure Rating
316 stainless steel	1/8, 1/4, 3/8, and 1/2 in.	15 000 psig (1034 bar)
	3/4 and 1 in.	10 000 psig (689 bar)

Temperature Ratings

System temperatures may be limited by the thread sealant.

Fitting Material	Maximum Temperature °F (°C)
316 stainless steel	1000 (537)

Elevated Temperature Factors

To determine allowable working pressure at elevated temperatures, multiply allowable working pressures shown above by a factor shown in the table below.

Temperature		Factors	
°F	°C	Strain-Hardened 316 SS	Annealed 316 SS
-60 to 200	-51 to 93	1.00	1.00
400	204	0.93	0.96
600	315	0.93	0.85
800	426	0.92	0.79
1000	537	0.84	0.76

Cleaning and Packaging

All medium-pressure pipe fittings are cleaned in accordance with Swagelok *Standard Cleaning and Packaging (SC-10)* (MS-06-62), page 1174.

Ordering Information and Dimensions

Dimensions are for reference only and are subject to change.

Couplings

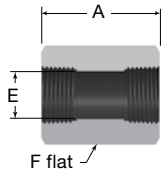

Female NPT

NPT Size in.	Ordering Number	Dimensions, in. (mm)			Pressure Rating psig (bar)
		A	E	F	
1/4	CN4NF15	1.25 (31.8)	0.44 (11.1)	3/4	15 000 (1034)
3/8	CN6NF15	1.38 (35.1)	0.58 (14.7)	1	
1/2	CN8NF15	1.50 (38.1)	0.70 (17.9)	1 3/8	
3/4	CN12NF10	1.75 (44.5)	0.92 (23.4)	1 3/8	10 000 (689)
1	CN16NF10	2.18 (55.4)	1.16 (29.4)	1 3/4	

Elbows

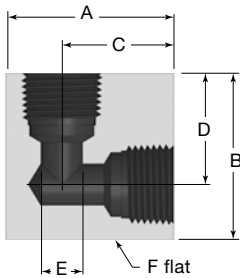

Female NPT

NPT Size in.	Ordering Number	Dimensions, in. (mm)						Pressure Rating psig (bar)
		A	B	C	D	E	F	
1/4	L4NF15	1.50 (38.1)	1.25 (31.8)	1.00 (25.4)	0.81 (20.6)	0.25 (6.4)	3/4	15 000 (1034)
3/8	L6NF15	1.50 (38.1)	1.50 (38.1)	1.00 (25.4)	1.00 (25.4)	0.38 (9.5)	1	
1/2	L8NF15	1.88 (47.8)	1.88 (47.8)	1.25 (31.6)	1.25 (31.6)	0.50 (12.7)	1 1/4	
3/4	L12NF10	2.62 (66.5)	2.12 (53.8)	1.31 (33.3)	1.38 (35.1)	0.92 (23.4)	1 1/2	10 000 (689)
1	L16NF10	3.00 (76.2)	2.56 (65.0)	1.69 (42.9)	1.69 (42.9)	0.69 (17.5)	1 3/4	

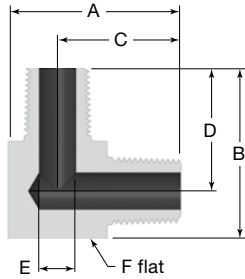

Male NPT

NPT Size in.	Ordering Number	Dimensions, in. (mm)						Pressure Rating psig (bar)
		A	B	C	D	E	F	
1/4	L4NM15	1.50 (38.1)	1.50 (38.1)	1.13 (28.7)	1.13 (28.7)	0.25 (6.4)	3/4	15 000 (1034)
3/8	L6NM15	1.75 (44.5)	1.75 (44.5)	1.25 (31.6)	1.25 (31.6)	0.38 (9.5)	1	
1/2	L8NM15	2.00 (50.8)	2.00 (50.8)	1.50 (38.1)	1.50 (38.1)	0.50 (12.7)	1	
3/4	L12NM10	2.62 (66.5)	2.62 (66.5)	1.75 (44.5)	1.75 (44.5)	0.63 (16.0)	1 1/2	10 000 (689)
1	L16NM10	3.00 (76.2)	3.00 (76.2)	2.13 (54.1)	2.13 (54.1)	0.69 (17.5)	1 3/4	

Street Elbows

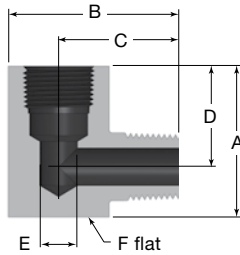

Female to Male NPT

NPT Size in.	Ordering Number	Dimensions, in. (mm)						Pressure Rating psig (bar)
		A	B	C	D	E	F	
1/4	L4NM4NF15	1.50 (38.1)	1.50 (38.1)	1.13 (28.7)	1.00 (25.4)	0.25 (6.4)	1	15 000 (1034)
3/8	L6NM6NF15	1.50 (38.1)	1.75 (44.5)	1.25 (31.6)	1.00 (25.4)	0.38 (9.5)	1	
1/2	L8NM8NF15	2.00 (50.8)	2.25 (57.2)	1.63 (41.4)	1.25 (31.6)	0.50 (12.7)	1 1/4	
3/4	L12NM12NF10	2.62 (66.5)	2.50 (63.5)	1.75 (44.5)	1.31 (33.3)	0.63 (16.0)	1 1/2	10 000 (689)
1	L16NM16NF10	2.88 (73.2)	3.00 (76.2)	2.12 (53.8)	1.68 (42.7)	0.69 (17.5)	1 3/4	

Tees

Female NPT

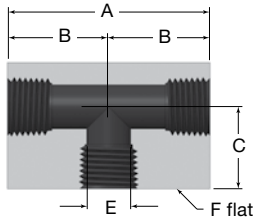

NPT Size in.	Ordering Number	Dimensions, in. (mm)					Pressure Rating psig (bar)
		A	B	C	E	F	
1/4	T4NF15	2.00 (50.8)	1.00 (25.4)	0.81 (20.6)	0.44 (11.1)	3/4	15 000 (1034)
3/8	T6NF15	2.00 (50.8)	1.00 (25.4)	1.00 (25.4)	0.38 (9.5)	1	
1/2	T8NF15	2.50 (63.5)	1.25 (31.6)	1.25 (31.8)	0.50 (12.7)	1 1/4	
3/4	T12NF10	2.62 (66.5)	1.31 (33.3)	1.38 (35.1)	0.92 (23.4)	1 1/2	10 000 (689)
1	T16NF10	3.38 (85.9)	1.69 (42.9)	1.69 (42.9)	0.69 (17.5)	1 3/4	

Male NPT^①

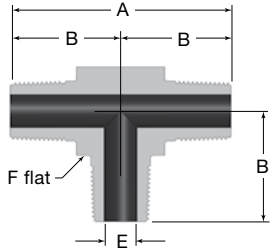

NPT Size in.	Ordering Number	Dimensions, in. (mm)				Pressure Rating psig (bar)
		A	B	E	F	
1/4	T4NM15	2.25 (57.2)	1.13 (28.7)	0.25 (6.4)	3/4	15 000 (1034)
3/8	T6NM15	2.50 (63.5)	1.25 (31.8)	0.38 (9.5)	1	
1/2	T8NM15	3.00 (76.2)	1.50 (38.1)	0.50 (12.7)	1	
3/4	T12NM10	3.50 (88.9)	1.75 (33.3)	0.63 (16.0)	1 1/2	10 000 (689)

① Additional sizes up to 1 in. are available.

Branch Tees

Male and Female NPT^①

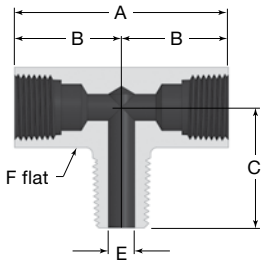

NPT Size in.	Ordering Number	Dimensions, in. (mm)					Pressure Rating psig (bar)
		A	B	C	E	F	
1/4	T4NF4NF4NM15	2.00 (50.8)	1.00 (25.4)	1.13 (28.7)	0.25 (6.4)	3/4	15 000 (1034)
3/8	T6NF6NF6NM15	2.00 (50.8)	1.00 (25.4)	1.06 (26.9)	0.38 (9.7)	1	
1/2	T8NF8NF8NM15	2.50 (63.5)	1.25 (31.6)	1.63 (41.4)	0.50 (12.7)	1 1/4	
3/4	T12NF12NF12NM10	2.62 (66.5)	1.31 (33.3)	1.75 (33.3)	0.63 (16.0)	1 1/2	10 000 (689)

① Additional sizes up to 1 in. are available.

Street Tees

Male and Female NPT^①

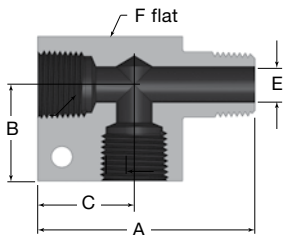

NPT Size in.	Ordering Number	Dimensions, in. (mm)					Pressure Rating psig (bar)
		A	B	C	E	F	
1/4	T4NF4NM4NF15	2.00 (50.8)	1.00 (25.4)	0.81 (20.6)	0.25 (6.4)	3/4	15 000 (1034)
3/8	T6NF6NM6NF15	2.25 (57.2)	1.00 (25.4)	1.00 (25.4)	0.38 (9.5)	1	
1/2	T8NF8NM8NF15	3.00 (76.2)	1.25 (31.6)	1.25 (31.6)	0.50 (12.7)	1 3/8	

① Additional sizes up to 1 in. are available.

Crosses

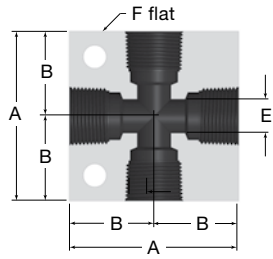

Female NPT

NPT Size in.	Ordering Number	Dimensions, in. (mm)				Pressure Rating psig (bar)
		A	B	E	F	
1/4	X4NF15	2.00 (50.8)	1.00 (25.4)	0.25 (6.4)	3/4	15 000 (1034)
3/8	X6NF15	2.00 (50.8)	1.00 (25.4)	0.38 (9.7)	1	
1/2	X8NF15	2.50 (63.5)	1.25 (31.6)	0.50 (12.7)	1 1/4	
3/4	X12NF10	2.62 (66.5)	1.31 (33.3)	0.92 (23.4)	1 1/2	10 000 (689)
1	X16NF10	4.12 (105)	2.06 (52.3)	0.69 (17.5)	1 3/4	

Bulkheads

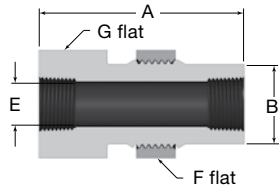

Female NPT

NPT Size in.	Ordering Number	Dimensions, in. (mm)						Panel Hole Size	Panel Thickness Max	Pressure Rating psig (bar)
		A	B	E	F	G				
1/4	BH4NF15	2.00 (50.8)	0.77 (19.6)	0.44 (11.2)	1	1	0.94 (23.9)	3/8	15 000 (1034)	
3/8	BH6NF15	2.62 (66.5)	1.02 (25.9)	0.58 (14.7)	1 3/8	1 3/8	1.25 (31.6)	1/2		
1/2	BH8NF15	2.62 (66.5)	1.20 (30.5)	0.70 (17.8)	1 7/8	1 1/2	1.37 (34.8)	1/2		
3/4	BH12NF10	2.62 (66.5)	1.52 (38.6)	0.63 (16.0)	1 7/8	1 7/8	1.69 (42.8)	1/2	10 000 (689)	
1	BH16NF10	3.50 (88.9)	1.76 (44.7)	0.69 (17.3)	2 1/8	2 1/8	1.94 (49.3)	1/2		

Pipe Caps

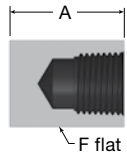

Female NPT^①

NPT Size in.	Ordering Number	Dimensions in. (mm)		Pressure Rating psig (bar)
		A	F	
1/4	CA4N15	1.00 (25.4)	3/4	15 000 (1034)
3/8	CA6N15	1.00 (25.4)	1	
1/2	CA8N15	1.25 (31.6)	1 3/8	
3/4	CA12N10	1.50 (38.1)	1 3/8	10 000 (689)

^① Additional sizes up to 1 in. are available.

Pipe Plugs

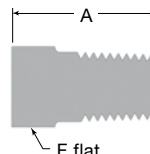

Male NPT

NPT Size in.	Ordering Number	Dimensions in. (mm)		Pressure Rating psig (bar)
		A	F	
1/4	PL4N	1.12 (28.4)	5/8	15 000 (1034)
3/8	PL6N	1.12 (28.4)	3/4	
1/2	PL8N	1.50 (38.1)	1	
3/4	PL12N	1.50 (38.1)	1 3/8	10 000 (689)
1	PL16N	1.88 (47.8)	1 3/8	

Safety Heads

Angled Style

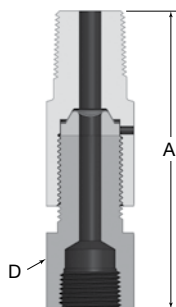

3/8 in. FNPT Outlet

Flat Style

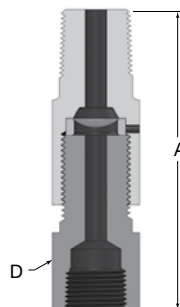

3/8 in. FNPT Outlet

Male NPT^①

NPT Size in.	Basic Ordering Number	Dimensions, in. (mm)		Pressure Rating psig (bar)
		A	D	
1/4	SH4NM_15	3.18 (80.8)	1	15 000 (1034)
3/8	SH6NM_15	3.17 (80.5)	1	
1/2	SH8NM_15	3.43 (87.1)	1	

^① Additional sizes up to 1 in. are available.

To order, insert **A** for 1/4 in. angled style; insert **F** for 1/2 in. flat style.

Rupture discs are not included. See **Options and Accessories** for ordering information, page 1095.

Line Filters

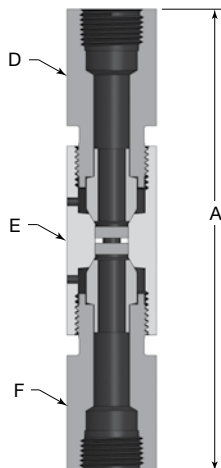

Female NPT

NPT Size in.	Basic Ordering Number	Dimensions, in. (mm)				Pressure Rating psig (bar)
		A	D	E	F	
1/4	LF4NF15-/_/_	4.19 (106)	7/8	1	7/8	15 000 (1034)
3/8	LF6NF15-/_/_	5.19 (132)	1	1	1	
1/2	LF8NF15-/_/_	5.79 (147)	1 3/8	1 3/8	1 3/8	
3/4	LF12NF10-/_/_	—	—	—	—	10 000 (689)
1	LF16NF10-/_/_	7.16 (182)	1 3/4	1 3/4	1 3/4	

Each line filter is designed with two filter elements—an upstream element and a downstream element. Filter elements are available in the following nominal pore sizes: 0.5, 2, 5, 10, 20, 40, and 100 µm. To order, add the filter element nominal pore sizes to the basic ordering number.

Example: For a line filter with an upstream, 40 µm filter element and a downstream, 20 µm filter elements, use ordering number: LF4NF15-40/20

Options and Accessories

NACE-Compliant Fittings for Sour Gas Service

All IPT series pipe fittings are available for sour gas service. Materials are selected in accordance with NACE MR0175/ISO 15156.

Technical Data

NACE Pressure Rating at 70°F (20°C)

NPT Size	Maximum Pressure Rating
1/8, 1/4, 3/8, and 1/2 in.	7 500 psig (517 bar)
3/4 and 1 in.	5 000 psig (344 bar)

Temperature Rating

Temperatures up 1000°F (537°C).

See Elevated Temperature Factors table on page 1091.

Materials of Construction

Annealed 316 stainless steel

Ordering Information

Select an ordering number from any **Dimensions** table and modify as follows. For ordering number ending in:

- 10, change to **5-NACE**
- 15, change to **10-NACE**

Example: Standard pipe fitting ordering number: CN2NF15
NACE ordering number: CN2NF15-**NACE**

Rupture Discs

- Shape: For angled (**A**) or flat (**F**) design safety heads
- Material: 316 stainless steel (**S**) or alloy 600 (**I**).
- Minimum order quantity = 3 pieces.
- Burst pressures: increments of 250 psig (17.2 bar) shown in *ksi* units.
 - Flat—500 to 10 000 psig (34.4 to 689 bar) (0.50 to 10.00 *ksi*)
 - Angled—1000 to 60 000 psig (68.9 to 4134 bar) (1.00 to 60.00 *ksi*)

To order, add the designators for shape, material, and burst pressure as shown below.

Typical ordering number:

RD **A S 10.50**

└─ Burst Pressure (ksi)

└─ Material

└─ Shape

Pipe Thread Sealants

Always use a pipe thread sealant when assembling tapered threads. SWAK anaerobic pipe thread sealant, PTFE-FREE pipe thread sealant, and Swagelok PTFE Tape are available.

See the Swagelok *Leak Detectors, Lubricants, and Sealants* catalog (MS-01-91), page 105 for more information.



High-Pressure Cone and Ferrule Fittings—Sno-Trik Series

For Pressures up to 60 000 psig (4134 bar)



- 316 stainless steel construction
- Temperatures up to 1000°F (537°C)
- Pressure rating up to 60 000 psig (4134 bar) with hardened tubing
- Pressure rating up to 30 000 psig (2067 bar) with annealed tubing
- End connections sizes: 1/4, 3/8, and 9/16 in.

Contents

Features, 1097

Materials of Construction, 1097

Pressure Ratings, 1097

Cleaning and Packaging, 1097

Ordering Information and Dimensions, 1097

HP Tube Fitting to HP Thread Connectors, 1097



Unions—Reducing, Bulkhead, Elbow and Tee, 1098



HP Male Thread to Coned Tube Stub Adapter, 1099



Port Connectors, Caps, Plugs, and Nuts, 1099



HP Tube Fitting to Pipe Thread Connectors, 1100



HP Tube Fitting to Swagelok Tube Fitting Unions, 1100



Coned Tube Stub Adapters, 1101



HP Male Thread to Pipe Thread Connectors, 1101



HP Male Thread to Swagelok Tube Fitting Adapters, 1101



HP Male Thread to Tube Socket Weld Adapters, 1102



Instructions for High-Pressure Cone and Ferrule Fittings, 1102

- Installation—Hardened Tubing
- Installation—Annealed Tubing
- Installation—High-Pressure Male and Female Threads
- Installation—Port Connectors
- Reassembly Instructions

Options and Accessories, 1103

- Pre-Setting Tool
- Sno-Trik Coning Tool
- Visual Tube Inspection

Swagelok High-Pressure Fittings

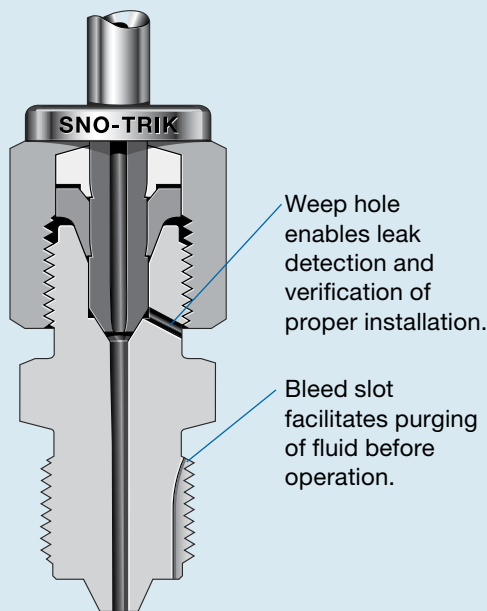

Features

- Fittings are machined from 316 stainless steel.
- Back ferrule is manufactured from S17400 hardened stainless steel to ensure a secure grip on hardened or annealed tubing.
- Unique ferrule action helps prevent excessive deformation of the seal area of tube end and body.
- Fitting does not reduce tube wall thickness.
- Fittings can be made, disconnected, and remade easily to provide a reliable leak-tight seal.

Pressure Ratings

High-Pressure Fitting

- The rating for high-pressure tube fittings and threaded connectors is determined with Swagelok hardened tubing at room temperature.
- The rating for high-pressure tube fittings and threaded connectors with annealed tubing is 30 000 psig (2067 bar) at room temperature.
- Working pressure determined based on ASME B31.3 Process Piping, Chapter IX High Pressure Piping.

Pipe Fitting

- Pipe thread pressure rating is based on laboratory testing with both male and female threads manufactured by Swagelok Company.

Materials of Construction

Component	Material
Back ferrule	S17400 SS
All other components	316 SS

Ordering Information and Dimensions

Dimensions are for reference only and are subject to change.

Cleaning and Packaging

All high-pressure fittings are cleaned in accordance with Swagelok *Standard Cleaning and Packaging (SC-10)* (MS-06-62), page 1174.

High-Pressure Tube Fitting to High-Pressure Male Thread Connectors

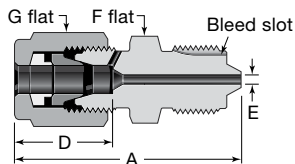

Tube OD in.	Uniform Thread Size	Ordering Number	Dimensions, in. (mm)					Pressure Rating psig (bar)
			A	D	E	F	G	
1/4	9/16-18	SS-440-1-44M	1.96 (49.8)	0.82 (20.8)	0.09 (2.3)	5/8	3/4	60 000 (4134)
	3/4-16	SS-440-1-64M	2.32 (58.9)			13/16		
3/8	9/16-18	SS-640-1-44M	2.24 (56.9)	1.04 (26.4)	0.09 (2.3)	13/16	15/16	
	3/4-16	SS-640-1-64M	2.41 (61.2)					
9/16	3/4-16	SS-940-1-64M	3.01 (76.5)	1.45 (36.8)	0.12 (3.0)	1 1/4	1 3/8	
	1 1/8-12	SS-940-1-94M	3.19 (81.0)					

High-Pressure Tube Fitting to High-Pressure Female Thread Connectors

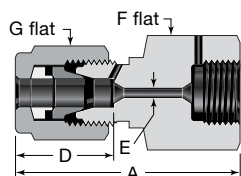

Tube OD in.	Uniform Thread Size	Ordering Number	Dimensions, in. (mm)					Pressure Rating psig (bar)
			A	D	E	F	G	
1/4	9/16-18	SS-440-7-44F	1.87 (47.5)	0.82 (20.8)	0.09 (2.3)	7/8	3/4	60 000 (4134)
3/8	3/4-16	SS-640-7-64F	2.26 (57.4)	1.04 (26.4)	0.12 (3.0)	1 1/8	15/16	
9/16	1 1/8-12	SS-940-7-94F	3.13 (79.5)	1.45 (36.8)	0.19 (4.8)	1 3/8	1 3/8	

Unions

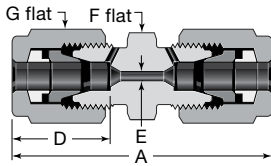

Tube OD in.	Ordering Number	Dimensions, in. (mm)					Pressure Rating psig (bar)
		A	D	E	F	G	
1/4	SS-440-6	2.25 (57.2)	0.82 (20.8)	0.09 (2.3)	5/8	3/4	60 000 (4134)
3/8	SS-640-6	2.70 (68.6)	1.04 (26.4)	0.12 (3.0)	13/16	15/16	
9/16	SS-940-6	3.69 (93.7)	1.45 (36.8)	0.19 (4.8)	1 1/4	1 3/8	

Reducing Unions

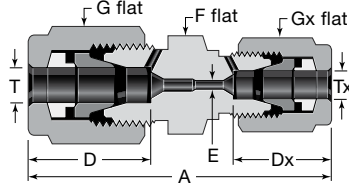

Tube OD, in.		Ordering Number	Dimensions, in. (mm)							Pressure Rating psig (bar)
T	Tx		A	D	Dx	E	F	G	Gx	
3/8	1/4	SS-640-6-440	2.61 (66.3)	1.04 (26.4)	0.82 (20.8)	0.09 (2.3)	13/16	15/16	3/4	60 000 (4134)
9/16	1/4	SS-940-6-440	3.22 (81.8)	1.45 (36.8)	0.82 (20.8)	0.09 (2.3)	1 1/4	1 3/8	3/4	
	3/8	SS-940-6-640	3.42 (86.9)		1.04 (26.4)	0.12 (3.0)			15/16	

Bulkhead Unions

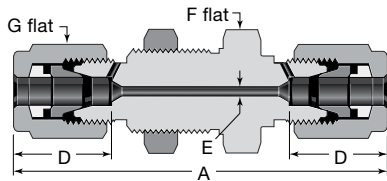

Tube OD in.	Ordering Number	Dimensions in. (mm)					Hole Drill Size	Panel Thickness Max in. (mm)	Pressure Rating psig (bar)
		A	D	E	F	G			
1/4	SS-440-61	3.30 (83.8)	0.82 (20.8)	0.09 (2.3)	15/16	3/4	0.78 (19.8)	60 000 (4134)	
3/8	SS-640-61	3.72 (94.5)	1.04 (26.4)	0.12 (3.0)	1 1/16	15/16	0.91 (23.1)		
9/16	SS-940-61	5.07 (129)	1.45 (36.8)	0.19 (4.8)	1 5/8	1 3/8	1.34 (34.0)		

Union Elbows

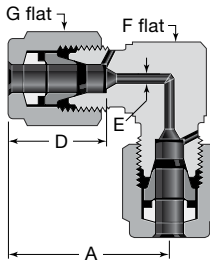

Tube OD in.	Ordering Number	Dimensions, in. (mm)					Pressure Rating psig (bar)
		A	D	E	F	G	
1/4	SS-440-9	1.39 (35.3)	0.82 (20.8)	0.09 (2.3)	11/16	3/4	60 000 (4134)
3/8	SS-640-9	1.74 (44.2)	1.04 (26.4)	0.12 (3.0)	7/8	15/16	
9/16	SS-940-9	2.52 (64.0)	1.45 (36.8)	0.19 (4.8)	1 1/4	1 3/8	

Union Tees

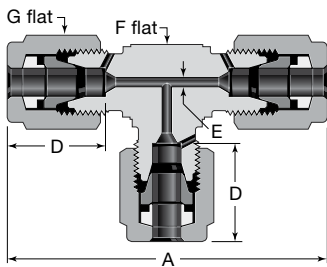

Tube OD in.	Ordering Number	Dimensions, in. (mm)					Pressure Rating psig (bar)
		A	D	E	F	G	
1/4	SS-440-3	2.78 (70.6)	0.82 (20.8)	0.09 (2.3)	11/16	3/4	60 000 (4134)
3/8	SS-640-3	3.48 (88.4)	1.04 (26.4)	0.12 (3.0)	7/8	15/16	
9/16	SS-940-3	5.04 (128)	1.45 (36.8)	0.19 (4.8)	1 1/4	1 3/8	

High-Pressure Male Thread Unions

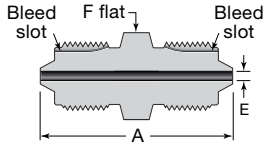

Uniform Thread Size	Ordering Number	Dimensions, in. (mm)			Pressure Rating psig (bar)
		A	E	F	
9/16-18	SS-44M-6	1.71 (43.4)	0.09 (2.3)	5/8	60 000 (4134)

High-Pressure Male Thread to Coned Tube Stub Adapters

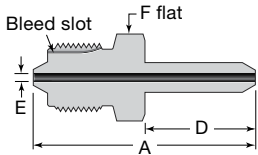

Tube OD in.	Uniform Thread Size	Ordering Number	Dimensions, in. (mm)				Pressure Rating psig (bar)
			A	D	E	F	
1/4	9/16-18	SS-44M-A-441	2.01 (51.1)	1.00 (25.4)	0.06 (1.5)	5/8	60 000 (4134)
3/8	3/4-16	SS-64M-A-641	2.47 (62.7)	1.25 (31.8)	0.12 (3.0)	13/16	
9/16	1 1/8-12	SS-94M-A-941	3.34 (84.8)	1.76 (44.7)	0.19 (4.8)	1 1/4	45 000 (3100)

Port Connectors

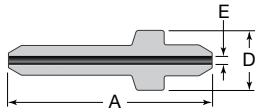

Tube OD in.	Ordering Number	Dimensions, in. (mm)			Pressure Rating psig (bar)
		A	D	E	
1/4	SS-441-PC	1.85 (47.0)	0.50 (12.7)	0.06 (1.5)	60 000 (4134)
3/8	SS-641-PC	2.33 (59.2)	0.68 (17.3)	0.12 (3.0)	
9/16	SS-941-PC	3.41 (86.6)	1.06 (26.9)	0.19 (4.8)	45 000 (3100)

Caps

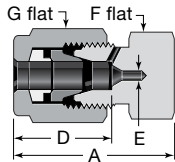

Tube OD in.	Ordering Number	Dimensions, in. (mm)					Pressure Rating psig (bar)
		A	D	E	F	G	
1/4	SS-440-C	1.35 (34.3)	0.82 (20.8)	0.09 (2.3)	5/8	3/4	60 000 (4134)
3/8	SS-640-C	1.80 (45.7)	1.04 (26.4)	0.12 (3.0)	13/16	15/16	
9/16	SS-940-C	2.52 (64.0)	1.45 (36.8)	0.19 (4.8)	1 1/4	1 3/8	

Plugs

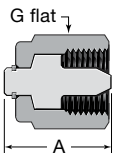

Tube OD in.	Ordering Number	Dimensions, in. (mm)		Pressure Rating psig (bar)
		A	G	
1/4	SS-440-P	0.95 (24.1)	3/4	60 000 (4134)
3/8	SS-640-P	1.18 (30.0)	15/16	
9/16	SS-940-P	1.66 (42.2)	1 3/8	

Nuts

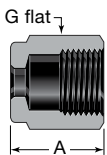

Tube OD in.	Ordering Number	Dimensions in. (mm)	
		A	G
1/4	SS-442-1	0.81 (20.6)	3/4
3/8	SS-642-1	0.97 (24.6)	15/16
9/16	SS-942-1	1.44 (36.6)	1 3/8

Front Ferrules



Tube OD in.	Ordering Number
1/4	SS-443-1
3/8	SS-643-1
9/16	SS-943-1

Back Ferrules



Tube OD in.	Ordering Number
1/4	174PH-444-1
3/8	174PH-644-1
9/16	174PH-944-1

High-Pressure Tube Fitting to Male Pipe Thread Connectors

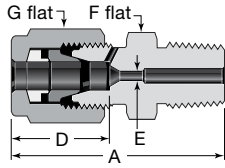

Tube OD in.	Male NPT Size in.	Ordering Number	Dimensions, in. (mm)					Pressure Rating psig (bar)
			A	D	E	F	G	
1/4	1/4	SS-440-1-4	1.84 (46.7)	0.82 (20.8)	0.09 (2.3)	5/8	3/4	15 000 (1034)
3/8	3/8	SS-640-1-6	2.09 (53.1)	1.04 (26.4)	0.12 (3.0)	13/16	15/16	
9/16	1/2	SS-940-1-8	2.80 (71.1)	1.45 (36.8)	0.19 (4.8)	1 1/4	1 3/8	

High-Pressure Tube Fitting to Male Pipe Thread Elbows

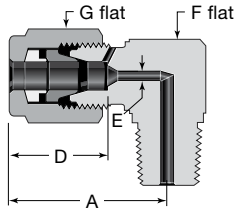

Tube OD in.	Male NPT Size in.	Ordering Number	Dimensions, in. (mm)					Pressure Rating psig (bar)
			A	D	E	F	G	
1/4	1/4	SS-440-2-4	1.50 (38.1)	0.82 (20.8)	0.09 (2.3)	7/8	3/4	15 000 (1034)
3/8	3/8	SS-640-2-6	1.74 (44.2)	1.04 (26.4)	0.12 (3.0)	7/8	15/16	
9/16	1/2	SS-940-2-8	2.52 (64.0)	1.45 (36.8)	0.19 (4.8)	1 1/4	1 3/8	

High-Pressure Tube Fitting to Female Pipe Thread Connectors

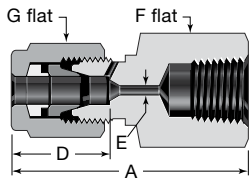

Tube OD in.	Female NPT Size in.	Ordering Number	Dimensions, in. (mm)					Pressure Rating psig (bar)
			A	D	E	F	G	
1/4	1/4	SS-440-7-4	2.07 (52.6)	0.82 (20.8)	0.09 (2.3)	15/16	3/4	15 000 (1034)
3/8	3/8	SS-640-7-6	2.36 (59.9)	1.04 (26.4)	0.12 (3.0)	1 3/16	15/16	
9/16	1/2	SS-940-7-8	2.99 (75.9)	1.45 (36.8)	0.19 (4.8)	1 1/2	1 3/8	

High-Pressure Tube Fitting to Swagelok Tube Fitting Unions

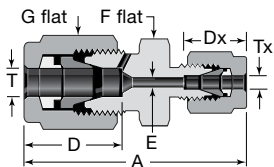

Tube OD, in.		Ordering Number	Dimensions, in. (mm)						Pressure Rating psig (bar)
T	Tx		A	D	Dx	E	F	G	
1/4	1/8	SS-440-6-200	1.88 (47.8)	0.82 (20.8)	0.50 (12.7)	0.09 (2.3)	5/8	3/4	10 900 (751)
3/8	1/4	SS-640-6-400	2.21 (56.1)	1.04 (26.4)	0.60 (15.2)	0.12 (3.0)	13/16	15/16	10 200 (702)
9/16	3/8	SS-940-6-600	2.80 (71.1)	1.45 (36.8)	0.66 (16.8)	0.19 (4.8)	1 1/4	1 3/8	7 500 (516)

High-Pressure Tube Fitting to Coned Tube Stub Reducers

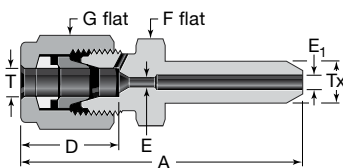

Tube OD, in.		Ordering Number	Dimensions, in. (mm)						Pressure Rating psig (bar)
T	Tx		A	D	E	E ₁	F	G	
1/4	3/8	SS-440-R-641	2.53 (64.3)	0.82 (20.8)	0.09 (2.3)	0.125 (3.0)	5/8	3/4	60 000 (4134)
3/8	9/16	SS-640-R-941	3.28 (83.3)	1.04 (26.4)	0.125 (3.0)	0.188 (4.8)	13/16	15/16	45 000 (3100)
9/16	3/8	SS-940-R-641	3.31 (84.1)	1.45 (36.8)	0.188 (4.8)	0.125 (3.0)	1 1/4	1 3/8	60 000 (4134)

Coned Tube Stub to Male Pipe Thread Adapters

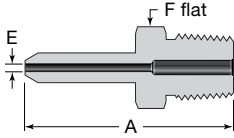

Tube OD in.	Male NPT Size in.	Ordering Number	Dimensions, in. (mm)			Pressure Rating psig (bar)
			A	E	F	
1/4	1/4	SS-441-A-4	1.84 (46.7)	0.06 (1.5)	9/16	15 000 (1034)
3/8	3/8	SS-641-A-6	2.12 (53.8)	0.12 (3.0)	11/16	
9/16	1/2	SS-941-A-8	2.85 (72.4)	0.19 (4.8)	7/8	

Coned Tube Stub to Swagelok Tube Fitting Adapters

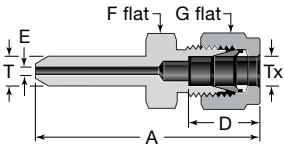

Tube OD, in.		Ordering Number	Dimensions, in. (mm)					Pressure Rating psig (bar)
T	Tx		A	D	E	F	G	
1/4	1/4	SS-441-A-400	1.97 (50.0)	0.60 (15.2)	0.06 (1.5)	1/2	9/16	10 200 (702)
3/8	3/8	SS-641-A-600	2.31 (58.7)	0.66 (16.8)	0.12 (3.0)	5/8	11/16	7 500 (516)
9/16	1/2	SS-941-A-810	2.96 (75.2)	0.90 (22.9)	0.19 (4.8)	13/16	7/8	6 700 (461)

High-Pressure Male Thread to Male Pipe Connectors

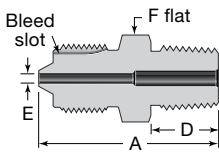

Thread Size	Male NPT Size in.	Ordering Number	Dimensions, in. (mm)				Pressure Rating psig (bar)
			A	D	E	F	
9/16-18	1/4	SS-44M-1-4	1.55 (39.4)	0.56 (14.2)	0.09 (2.3)	5/8	15 000 (1034)
3/4-16	3/8	SS-64M-1-6	1.78 (45.2)	0.56 (14.2)	0.12 (3.0)	13/16	
1 1/8-12	1/2	SS-94M-1-8	2.30 (58.4)	0.75 (19.0)	0.19 (4.8)	1 1/4	

High-Pressure Male Thread to Female Pipe Connectors

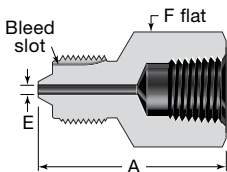

Thread Size	Female NPT Size in.	Ordering Number	Dimensions, in. (mm)			Pressure Rating psig (bar)
			A	E	F	
9/16-18	1/4	SS-44M-7-4	1.66 (42.2)	0.09 (2.3)	15/16	15 000 (1034)
3/4-16	3/8	SS-64M-7-6	1.94 (49.3)	0.12 (3.0)	1 3/16	
1 1/8-12	1/2	SS-94M-7-8	2.48 (63.0)	0.19 (4.8)	1 1/2	

High-Pressure Male Thread to Swagelok Tube Fitting Adapters

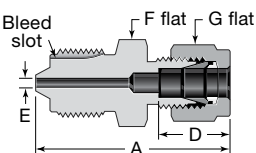

Tube OD in.	Thread Size	Ordering Number	Dimensions, in. (mm)					Pressure Rating psig (bar)
			A	D	E	F	G	
1/8	9/16-18	SS-44M-A-200	1.61 (40.8)	0.50 (12.7)	0.09 (2.3)	5/8	7/16	10 900 (751)
1/4	9/16-18	SS-44M-A-400	1.70 (43.1)	0.60 (15.2)	0.09 (2.3)	5/8	9/16	10 200 (702)
3/8	3/4-16	SS-64M-A-600	1.97 (50.0)	0.66 (16.7)	0.12 (3.0)	13/16	11/16	7 500 (516)
1/2	1 1/8-12	SS-94M-A-810	2.41 (61.2)	0.90 (22.9)	0.19 (4.8)	1 1/4	7/8	6 700 (461)

High-Pressure Male Thread to Tube Socket Weld Adapters

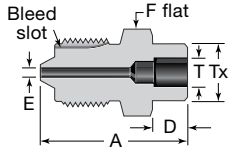

Tube OD, in.		Thread Size	Ordering Number	Dimensions, in. (mm)				Pressure Rating psig (bar)
T	Tx			A	D	E	F	
1/4	1/2	9/16-18	SS-44M-A-4TSW	1.30 (33.0)	0.28 (7.1)	0.09 (2.3)	5/8	20 000 (1378)
3/8	5/8	3/4-16	SS-64M-A-6TSW	1.60 (40.6)	0.31 (7.9)	0.12 (3.0)	13/16	20 000 (1378)
1/2	3/4	1 1/8-12	SS-94M-A-8TSW	1.99 (50.5)	0.38 (9.7)	0.19 (4.8)	1 1/4	15 000 (1034)

Instructions for High-Pressure Cone and Ferrule Tube Fittings

Installation—Hardened Tubing

⚠ The pre-setting tool (see page 1103) must be used for proper initial installation of high-pressure tube fittings with hardened tubing.

1. Install the nut and ferrules onto the pre-setting tool.
2. Insert the coned tubing into the pre-setting tool.
3. Make sure that the tubing rests firmly on the tapered shoulder of the pre-setting tool body.
4. Tighten the nut *until the tubing cannot be turned by hand*.
5. Mark the nut at the 6 o'clock position.
6. While holding the pre-setting tool steady, tighten the nut one and one-fourth turns to the 9 o'clock position.
7. Loosen the nut and remove the tubing with pre-set ferrules from the pre-setting tool.
8. Insert tubing with pre-set ferrules into the fitting body until the front ferrule seats; rotate the nut *finger-tight*.
9. While holding fitting body steady, tighten the nut three-eighths turn for 3/8 and 9/16 in. tubing and one-fourth turn for 1/4 in. tubing.

Installation—Annealed Tubing

The pre-setting tool is suggested for proper installation of high-pressure tube fittings with annealed tubing. When the pre-setting tool is used, use the instructions for hardened tubing. When the pre-setting tool is not used, use the following instructions:

1. Insert coned tubing into the tube fitting.
2. Make sure that the tubing rests firmly on the tapered shoulder of the tube fitting body.
3. Tighten the nut *until the tubing cannot be turned by hand*.
4. Mark the nut at the 6 o'clock position.
5. While holding fitting body steady, tighten the nut one and one-fourth turns to the 9 o'clock position.

Installation—High-Pressure Male and Female Threads

1. Rotate the nut *finger-tight*.
2. Tighten the nut one-eighth turn.

Installation—Port Connectors

1. Remove the nut and ferrules from the first of the two high-pressure tube fitting ports to be connected. Discard the ferrules.

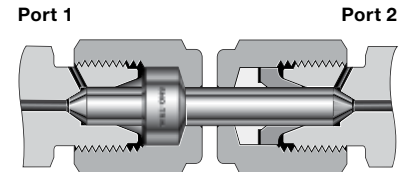

2. Slip the nut over the short end of the port connector. See illustration, port 1.
3. Remove the nut and ferrules from port 2 and install them onto the pre-setting tool.
4. Insert the long end of the port connector into the pre-setting tool, making sure that it rests firmly on the tapered shoulder of the tool body.
5. Tighten the nut *until the port connector cannot be turned by hand*.
6. Mark the nut at the 6 o'clock position.
7. While holding the pre-setting tool steady, tighten the nut one and one-fourth turns to the 9 o'clock position.
8. Loosen the nut and remove the port connector end with pre-set ferrules from the pre-setting tool.
9. Insert the port connector end with pre-set ferrules into port 2 until the front ferrule seats; rotate the nut *finger-tight*.
10. While holding fitting body steady, tighten the nut three-eighths turn for 3/8 and 9/16 in. tubing and one-fourth turn for 1/4 in. tubing.
11. Tighten the first nut onto port 1 *finger-tight*.
12. While holding fitting body steady, tighten the nut three-eighths turn for 3/8 and 9/16 in. tubing and one-fourth turn for 1/4 in. tubing.

Reassembly Instructions

You may disassemble and reassemble a Swagelok high-pressure tube fitting.

1. Insert tubing with pre-set ferrules into the fitting body until the front ferrule seats; rotate the nut *finger-tight*.
2. While holding fitting body steady, tighten the nut three-eighths turn for 3/8 and 9/16 in. tubing and one-fourth turn for 1/4 in. tubing.

Options and Accessories

Pre-Setting Tool

The pre-setting tool is suggested for initial assembly of Swagelok high-pressure tube fittings when used with annealed tubing. The pre-setting tool **must** be used for initial assembly of these tube fittings when used with Swagelok hardened tubing.



Tube OD/ Tool Size, in.	Ordering Number	Minimum OD Required, in.
1/4	MS-440-PT	0.250
3/8	MS-640-PT	0.375
9/16	MS-940-PT	0.562

Visual Tube Inspection

- A proper cone has ends that are faced and smooth.
- The cone should be free of any scratches and leave-off marks.

Tube Preparation	
T, in.	N, in.
1/4	1/8
3/8	7/32
9/16	9/32

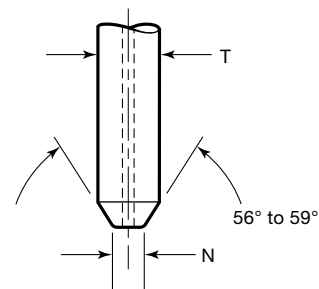

Sno-Trik Coning Tool

High-pressure tubing used with Swagelok high-pressure tube fittings should be prepared with a Swagelok coning tool. The Swagelok coning tool cuts a smooth, concentric cone on the tube end to help ensure reliable sealing in the fitting body. It is designed to prepare 1/4, 3/8, and 9/16 in. outside diameter heavy wall tubing.



Each coning tool comes in a carrying case with Rapid Tap™ cutting lubricant; 1/4, 3/8, and 9/16 in. collets and tool bits; and inside-diameter deburring tool.

Ordering number: **MS-469-CT**

For operating instructions, see the *Coning Tool User's Manual*, MS-CRD-CONING.

Tubing Selection

High-pressure cone and ferrule fittings can be used with 316 stainless steel, hardened or annealed, high-pressure tubing. See the Tubing/Fitting Compatibility matrix on page 1105 for details.

Replacement Parts

To order additional items separately, select an ordering number.

Description	Ordering Number
Cutting lubricant	MS-469CT-LUBE
1/4 in. collet	MS-469CT-2-4
1/4 in. tool bit	MS-469CT-7-4
3/8 in. collet	MS-469CT-2-6
3/8 in. tool bit	MS-469CT-7-6
9/16 in. collet	MS-469CT-2-9
9/16 in. tool bit	MS-469CT-7-9
Deburring tool	MS-44CT-27

Custom Manifolds—IPT Series

For Pressures up to 60 000 psig (4134 bar)



- Pressure manifolds minimize space requirements.
- Reduce installation time necessary to plumb a pressure system.
- Minimize the number of potential leak points by reducing the number of components used in a system.
- Available with Swagelok medium-pressure tube fitting—FK series, cone and thread, or NPT end connections.
- Hardware included.

How to Order

Custom manifolds up to 20 in. long are available depending on the end connection size and bore size. Contact your authorized Swagelok representative with your requirements.

Medium-Pressure Tubing—FK Series

For Pressures up to 20 000 psig (1378 bar)



- For use with Swagelok medium-pressure, gaugeable tube fittings and adapter fittings—FK series
- 316 / 316L stainless steel seamless tubing
 - heavy-wall annealed
 - cold-drawn 1/8-hard
- Working pressures up to 20 000 psig (1378 bar)
- Sizes 1/4, 3/8, 1/2, and 3/4 in. outside diameter

Features

- 316/316L stainless steel seamless tubing available annealed or cold-drawn.
- Sized as true OD tubing.
- Supplied in fractional lengths of 20 ft. and metric lengths up to 6 meters.
- Marked to indicate size, material, condition, and heat number.

Technical Data

Material Standards and Mechanical Properties

Cold-drawn 1/8-hard tubing has increased material strength which allows for reduced wall thickness and enhanced flow through the same diameter tube.

Heavy-Wall Annealed 316 / 316L Stainless Steel Seamless Tubing

Grade	UNS	Specification
316 / 316L, 1.4401 / 1.4404	S31600 / S31603	ASTM A213 ^① , A269
		ASME SA213 ^①
		EN 10216-5 ^②

① Nominal wall thickness, not minimum wall thickness.
 ② Appearance in accordance with ASTM / ASME standards.

Cold-Drawn 1/8-Hard 316 / 316L Stainless Steel Seamless Tubing

Grade	UNS	Specification	Minimum Yield Strength at 0.2 Offset ^③ ksi	Minimum Tensile Strength ^③ ksi	Elongation in 2 in. (50.8 mm) ^③ % min
316 / 316L, 1.4401 / 1.4404	S31600 / S31603	ASTM A213 ^① , A269	75	105	20
		ASME SA213 ^①			
		EN 10216-5 ^②			

① Nominal wall thickness, not minimum wall thickness.
 ② Appearance in accordance with ASTM / ASME standards.
 ③ Exception to the standards.

Tubing/Fitting Compatibility Matrix

The medium-pressure FK series tubing, the IPT series cone and thread tubing, and the high-pressure Sno-Trik series tubing, generally are not compatible with other series of medium- and high-pressure fittings in this catalog. See the table below for compatibility by series.

Tubing			Fitting		
			FK Series Medium Pressure	IPT Series Cone & Thread Medium & High Pressure	Sno-Trik Series High Pressure
Description	Sizing	Specifacaton			
FK Series Medium-Pressure Tubing	True OD Tubing	ASTM A213 and ASTM A269	Yes, except 9/16 in.	No	No
IPT Series Cone & Thread Tubing	Nominal OD Tubing	ASTM 213	9/16 and 3/4 in. ONLY	Yes	No
Sno-Trik Series High-Pressure Tubing	True OD Tubing	ASTM A269	No	No	Yes

MEDIUM- AND HIGH-PRESSURE

Chemical Composition

Element	Specification
	ASTM / EN
	Composition, wt. %
Chromium	16.5 to 18.0
Nickel	11.0 to 13.0
Molybdenum	2.00 to 2.50
Manganese	2.00 max
Silicon	1.00 max
Carbon	0.030 max
Sulfur	

Bend Radius

The recommended bend radius and wall thickness limits for making a bend in heavy-wall annealed or cold-drawn 1/8-hard stainless steel seamless tubing are listed below.

Tube OD in.	Recommended Bend Radius in. (mm)	Nominal Wall Thickness, in.	
		Heavy-Wall Annealed Stainless Steel Seamless	Cold-Drawn 1/8-Hard Stainless Steel Seamless
1/4	1.4 (36)	0.095	0.065
3/8		0.134	0.083
1/2		0.188	0.109
3/4	2.2 (56)	—	0.165

⚠ Do not use hand tube bender for bending heavy-wall annealed or cold-drawn 1/8-hard stainless steel tubing. Use steel bend shoes with the Swagelok bench top tube bender.

For more information about bending medium-pressure tubing, see the *Swagelok Bench Top Tube Bender User's Manual*, MS-13-145.

Ordering Information and Dimensions

Heavy-Wall Annealed 316 / 316L Stainless Steel Seamless Tubing

ASTM / EN Tubing

Tube OD in.	Nominal OD in.	Nominal Wall Thickness in.	Ordering Number	Nominal Length	Weight	Pressure Rating ^①
Fractional Length				ft	lb/ft (kg/m)	psig (bar)
1/4	0.250	0.095	SS-T4FK-S-095-20-S	20	0.16 (0.24)	15 000 (1034)
3/8	0.375	0.134	SS-T6FK-S-134-20-S		0.35 (0.52)	
1/2	0.500	0.188	SS-T8FK-S-188-20-S		0.64 (0.95)	
Metric Length				m	kg/m (lb/ft)	bar (psig)
1/4	0.250	0.095	SS-T4FK-S-095-6M-S	6	0.24 (0.16)	1034 (15 000)
3/8	0.375	0.134	SS-T6FK-S-134-6M-S		0.52 (0.35)	
1/2	0.500	0.188	SS-T8FK-S-188-6M-S		0.95 (0.64)	

① Working pressure determined based on ASME B31.3 Process Piping.

Cold-Drawn 1/8-Hard 316 / 316L Stainless Steel Seamless Tubing

ASTM / EN Tubing

Tube OD in.	Nominal OD in.	Nominal Wall Thickness in.	Ordering Number	Nominal Length	Weight	Pressure Rating	
						ASME B31.3 ^①	Chapter IX ^②
Fractional Length				ft	lb/ft (kg/m)	psig (bar)	
1/4	0.250	0.065	SS-T4FK-SH-065-20-S	20	0.13 (0.19)	15 000 (1034)	20 000 (1378)
3/8	0.375	0.083	SS-T6FK-SH-083-20-S		0.26 (0.39)		
1/2	0.500	0.109	SS-T8FK-SH-109-20-S		0.47 (0.70)		
3/4	0.750	0.165	SS-T12FK-SH-165-20-S		1.05 (1.56)		
Metric Length				m	kg/m (lb/ft)	bar (psig)	
1/4	0.250	0.065	SS-T4FK-SH-065-2M-S	2	0.19 (0.13)	1034 (15 000)	1378 (20 000)
			SS-T4FK-SH-065-4M-S	4			
			SS-T4FK-SH-065-6M-S	6			
3/8	0.375	0.083	SS-T6FK-SH-083-2M-S	2	0.39 (0.26)		
			SS-T6FK-SH-083-4M-S	4			
			SS-T6FK-SH-083-6M-S	6			
1/2	0.500	0.109	SS-T8FK-SH-109-2M-S	2	0.70 (0.47)		
			SS-T8FK-SH-109-4M-S	4			
			SS-T8FK-SH-109-6M-S	6			
3/4	0.750	0.165	SS-T12FK-SH-165-6M-S	6	1.56 (1.05)		

① Working pressure determined based on ASME B31.3 Process Piping.

② Working pressure determined based on ASME B31.3 Process Piping, Chapter IX High Pressure Piping.

Additional Products

Alloy 2507 Tubing

Swagelok Alloy 2507 seamless super duplex tubing can be used in many medium-pressure applications. For more information, see the Swagelok *Alloy 2507 Seamless Super Duplex Tubing—Fractional Sizes* catalog (MS-02-151), page 203.



Cone and Thread Tubing and Tube Nipples—IPT Series

For Pressures up to 60 000 psig (4134 bar)



- For use with cone and thread products
- 316/316L stainless steel tubing and tube nipples
- Medium-pressure (MP) tubing
 - Size range—1/4 to 1 in.
 - Pressure rating—up to 20 000 psig (1378 bar)
- High-pressure (HP) tubing
 - Size range—1/4 to 9/16 in.
 - Pressure rating—up to 60 000 psig (4134 bar)

Features

- 316/316L stainless steel seamless tubing available cold-drawn.
- Sized as nominal OD tubing.
- Supplied in random lengths averaging 24 ft (20 to 27 ft).
- Marked to indicate size, material, condition, and heat number.

Technical Data

Material Standards and Mechanical Properties

Grade	UNS	Specification	Service Rating psig (bar)	Minimum Yield Strength at 0.2 % Offset ^① ksi	Minimum Tensile Strength ksi	Elongation in 2 in. (50.8 mm) ^① % min
316 / 316L, 1.4401 / 1.4404	S31600 / S31603	ASTM A213 ^①	20 000 (1378)	75	105	22
			60 000 (4134)	100	110	18

① Chemical properties only.

Chemical Composition

Element	Specification
	ASTM
	Composition, wt. %
Chromium	16.5 to 18.0
Nickel	11.0 to 13.0
Molybdenum	2.00 to 3.00
Manganese	2.00 max
Silicon	0.75 max
Carbon	0.030 max
Sulfur	0.030 max

Bend Radius

The recommended bend radius and wall thickness limits for making a bend in cold-drawn, stainless steel seamless tubing are listed below.

Nominal Tube OD in.	Minimum Bend Radius (in. Mandrel Radius)
Medium Pressure: 20 000 psig (1378 bar)	
1/4	1.25
3/8	1.75
9/16	2.625
3/4	3.50
1	4.625
High Pressure: 60 000 psig (4134 bar)	
1/4	1.25
3/8	1.75
9/16	2.625

⚠ Do not use hand tube bender for bending heavy-wall annealed or cold-drawn 1/8-hard stainless steel tubing. Use steel bend shoes with the Swagelok bench top tube bender for sizes 1/4 in. - 9/16 in., for larger sizes it is recommended using an electric bender.

For more information about bending medium-pressure tubing, see the *Swagelok Bench Top Tube Bender User's Manual*, MS-13-145.

Ordering Information and Dimensions

Bulk Tubing for Cone and Thread Products

- Ordering numbers in the table are for 316/316L stainless steel material.
- Custom lengths and other materials are available upon request. Contact your authorized Swagelok representative.

Fractional Tube OD in.	Nominal Tube OD in.	Nominal Tube ID in.	Ordering Number	Length ft (m)	Weight lb/ft (kg/m)
Medium Pressure: 20 000 psig (1378 bar)					
1/4	0.248 – 0.243	0.104 – 0.109	TU4M20	20 to 27 (6.1 to 8.2)	0.13 (0.19)
3/8	0.370 – 0.365	0.198 – 0.203	TU6M20		0.26 (0.39)
9/16	0.557 – 0.552	0.307 – 0.312	TU9M20		0.57 (0.85)
3/4	0.745 – 0.740	0.432 – 0.438	TU12M20		0.98 (1.46)
1	0.995 – 0.990	0.557 – 0.562	TU16M20		1.81 (2.69)
High Pressure: 60 000 psig (4134 bar)					
1/4	0.248 – 0.243	0.079 – 0.083	TU4H60	20 to 27 (6.1 to 8.2)	0.15 (0.22)
3/8	0.370 – 0.365	0.121 – 0.125	TU6H60		0.33 (0.49)
9/16	0.557 – 0.552	0.182 – 0.187	TU9H60		0.74 (1.10)

Tube Nipples for Cone and Thread Products

- Ordering numbers in the table are for cold-drawn, 316/316L stainless steel material. Other materials are available.
- Custom length tube nipples are available upon request. Contact your authorized Swagelok representative.
- To order, add the length in inches (up to 2 decimal places) to the basic ordering number. Example: N4M20-**2.75**



Fractional Tube OD in.	Nominal Tube OD in.	Basic Ordering Number	Dimensions in. (mm)		
			A Minimum Length	E	Tube Engagement Length
Medium Pressure: 20 000 psig (1378 bar)					
1/4	0.248 – 0.243	N4M20-	2.00 (50.8)	0.109 (2.77)	0.56 (14.2)
3/8	0.370 – 0.365	N6M20-	2.50 (63.5)	0.203 (5.16)	0.69 (17.5)
9/16	0.557 – 0.552	N9M20-	3.00 (76.2)	0.312 (7.92)	0.84 (21.3)
3/4	0.745 – 0.740	N12M20-	3.25 (82.6)	0.438 (11.1)	1.00 (25.4)
1	0.995 – 0.990	N16M20-	4.50 (114)	0.562 (14.3)	1.47 (37.3)
High Pressure: 60 000 psig (4134 bar)					
1/4	0.248 – 0.243	N4H60-	2.75 (69.8)	0.083 (2.11)	0.50 (12.7)
3/8	0.370 – 0.365	N6H60-	3.00 (76.2)	0.125 (3.18)	0.69 (17.5)
9/16	0.557 – 0.552	N9H60-	4.00 (102)	0.188 (4.78)	0.88 (22.4)

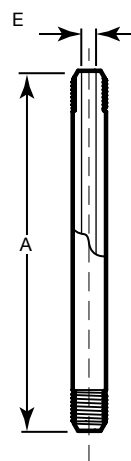

High-Pressure Tubing and Tube Nipples—Sno-Trik

For Pressures up to 60 000 psig (4134 bar)



- For use with high-pressure Sno-Trik products
- 316 / 316L stainless steel seamless tubing
 - hardened
 - annealed
- Pressure rating
 - up to 60 000 psig (4134 bar) with hardened tubing
 - up to 30 000 psig (2067 bar) with annealed tubing
- Sizes 1/4, 3/8, and 9/16 in. outside diameter

Features

- 316/316L stainless steel seamless tubing available annealed or strain-hardened.
- Sized as true OD tubing.
- Supplied in random lengths averaging 24 ft (20 to 27 ft).
- Available in custom lengths upon request.
- Marked to indicate size, material, condition, and heat number.

Technical Data

Material Standards and Mechanical Properties

Strain-hardened tubing is more robust and allows for reduced wall thickness and enhanced flow through the same diameter tube.

Grade	UNS	Specification	Minimum Yield Strength at 0.2 % Offset ksi	Minimum Tensile Strength ksi	Elongation in 2 in. (50.8 mm) % min
Strain-Hardened 316 / 316L Stainless Steel Seamless Tubing					
316 / 316L	S31600 / S31603	ASTM A269 ASTM A262 EN ISO3651-2	75	100	20
Annealed 316 / 316L Stainless Steel Seamless Tubing					
316 / 316L	S31600 / S31603	ASTM A269 ASTM A262 EN ISO3651-2	40	70	35

Chemical Composition

Element	Specification
	ASTM
	Composition, wt. %
Chromium	17.0 to 18.0
Nickel	10.0 to 15.0
Molybdenum	2.50 to 3.00
Manganese	2.00 max
Silicon	0.75 max
Carbon	0.035 max
Sulfur	0.030 max

Bend Radius

The recommended bend radius and wall thickness limits for making a bend in cold-drawn, stainless steel seamless tubing are listed below.

Tube OD in.	Wall Thickness in. (mm)	Minimum Bend Radius (in. Mandrel Radius)
1/4	0.083 (2.1)	1.25
1/4	0.095 (2.4)	1.25
3/8	0.125 (3.2)	1.75
9/16	0.187 (4.7)	2.625

⚠ Do not use hand tube bender for bending heavy-wall annealed or cold-drawn 1/8-hard stainless steel tubing. Use steel bend shoes with the Swagelok bench top tube bender.

For more information about bending medium-pressure tubing, see the *Swagelok Bench Top Tube Bender User's Manual*, MS-13-145.

Ordering Information and Dimensions

Dimensions are for reference only and are subject to change.

Bulk Tubing for High-Pressure Products

- Tube lengths of hardened or annealed tubing are available in 120 in. (305 cm) lengths.
- Tube lengths are precisely coned with a high-quality finish.
- Annealed tubing is rated to 30 000 psig (2067 bar).
- Hardened tubing is rated to 60 000 psig (4134 bar).

Tube OD in.	Nominal Tube OD in.	Wall Thickness in. (mm)	Length in. (cm)	Ordering Number	
				Hardened Tubing	Annealed Tubing
1/4	0.250	0.083 (2.1)	120 (305)	SS-483-T-120	SS-483-A-120
1/4	0.250	0.095 (2.4)	120 (305)	SS-495-T-120	SS-495-A-120
3/8	0.375	0.125 (3.2)	120 (305)	SS-612-T-120	SS-612-A-120
9/16	0.563	0.187 (4.7)	120 (305)	SS-918-T-120	SS-918-A-120

Tube Nipples for High-Pressure Products

- Pre-coned tube nipples of hardened or annealed tubing are available from 2 to 12 in. (5.1 to 30.5 cm) in length.
- Tube nipples are precisely coned with a high-quality finish.
- Annealed tube nipples are rated to 30 000 psig (2067 bar).
- Hardened tube nipples are rated to 60 000 psig (4134 bar).

Tube OD in.	Nominal Tube OD in.	Wall Thickness in. (mm)	A Length in. (cm)	Ordering Numbers	
				Hardened Tube Nipple	Annealed Tube Nipple
1/4	0.250	0.083 (2.1)	2 (5.1)	SS-483-T-2	SS-483-A-2
			4 (10.2)	SS-483-T-4	SS-483-A-4
			8 (20.3)	SS-483-T-8	SS-483-A-8
			12 (30.5)	SS-483-T-12	SS-483-A-12
1/4	0.250	0.095 (2.4)	4 (10.2)	SS-495-T-4	SS-495-A-4
			8 (20.3)	SS-495-T-8	SS-495-A-8
			12 (30.5)	SS-495-T-12	SS-495-A-12
3/8	0.375	0.125 (3.2)	3 (7.6)	SS-612-T-3	SS-612-A-3
			4 (10.2)	SS-612-T-4	SS-612-A-4
			8 (20.3)	SS-612-T-8	SS-612-A-8
			12 (30.5)	SS-612-T-12	SS-612-A-12
9/16	0.563	0.187 (4.7)	4 (10.2)	SS-918-T-4	SS-918-A-4
			8 (20.3)	SS-918-T-8	SS-918-A-8
			12 (30.5)	SS-918-T-12	SS-918-A-12

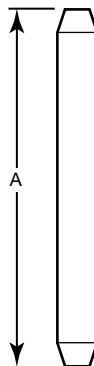

Medium-Pressure Trunnion-Style Ball Valves— FKB Series

For Pressures up to
20 000 psig (1378 bar)



- Pressure rating: up to 20 000 psig (1378 bar)
- Temperatures up to 250°F (121°C)
- 316 stainless steel construction
- Three valve series / orifices sizes:
0.209 in. (5.31 mm) for 6FKB series;
0.375 in. (9.52 mm) for 8FKB series;
0.560 in. (14.2 mm) for 12FKB series
- End connection sizes: 1/4 to 1 in.
- 2-way (on-off) and 3-way (switching) flow patterns

Features

Swagelok FKB series trunnion-style ball valves offer low-torque, quarter-turn operation in a compact design providing positive shutoff in applications up to 20 000 psig (1378 bar). Other features include:

- 2-way valves—bidirectional; 3-way valves—common side or bottom inlet port.
- Flow coefficients (C_V) from 0.44 to 11.3.
- Gaugeable Swagelok medium-pressure tube fitting, female NPT, and cone and thread end connections.
- Positionable bar handle
- ISO 5211-compliant pneumatic actuators.
- Three mounting options include:
 - Panel mount using optional panel nut
 - Two bolts through panel into top of valve body
 - Bolted through body mounting holes with dual bolt pattern for OEM valve replacement.

Pressure-Temperature Ratings

316 Stainless Steel with Fluorocarbon FKM O-Rings			
Temperature °F (°C)	Valve Orifice Size, in (mm)	Working Pressure, psig (bar) ^{①②③}	
		2-way	3-way
0 (-17) to 250 (121)	0.209 (5.31)	20 000 (1378)	
	0.375 (9.52)	20 000 (1378)	15 000 (1034)
	0.560 (14.2)	15 000 (1034)	—

① Working pressure determined based on ASME B31.3 Process Piping, Chapter IX High Pressure Piping.

② Sizes above 1/2 in. FNPT have a working pressure of 10 000 psig (689 bar).

③ Sizes of 1/2 in. FNPT and below have a working pressure of 15 000 psig (1034 bar).

Important Information About Ball Valves

- ⚠ **Swagelok ball valves are designed to be used in a fully open or fully closed position.**
- ⚠ **Valves that have not been cycled for a period of time may have a higher initial actuation torque.**
- ⚠ **To avoid damage and over-actuation, do not attempt to actuate past positive stop**

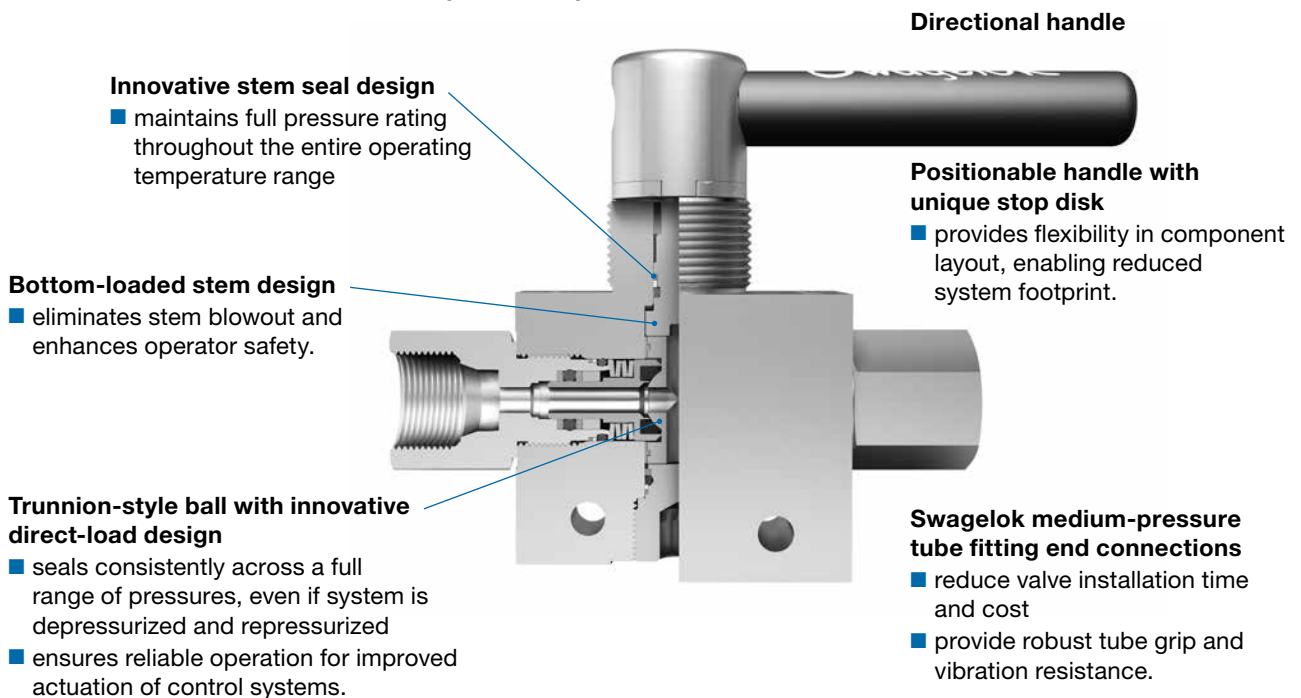

Innovative stem seal design

- maintains full pressure rating throughout the entire operating temperature range

Bottom-loaded stem design

- eliminates stem blowout and enhances operator safety.

Trunnion-style ball with innovative direct-load design

- seals consistently across a full range of pressures, even if system is depressurized and repressurized
- ensures reliable operation for improved actuation of control systems.

Directional handle

Positionable handle with unique stop disk

- provides flexibility in component layout, enabling reduced system footprint.

Swagelok medium-pressure tube fitting end connections

- reduce valve installation time and cost
- provide robust tube grip and vibration resistance.

Materials of Construction

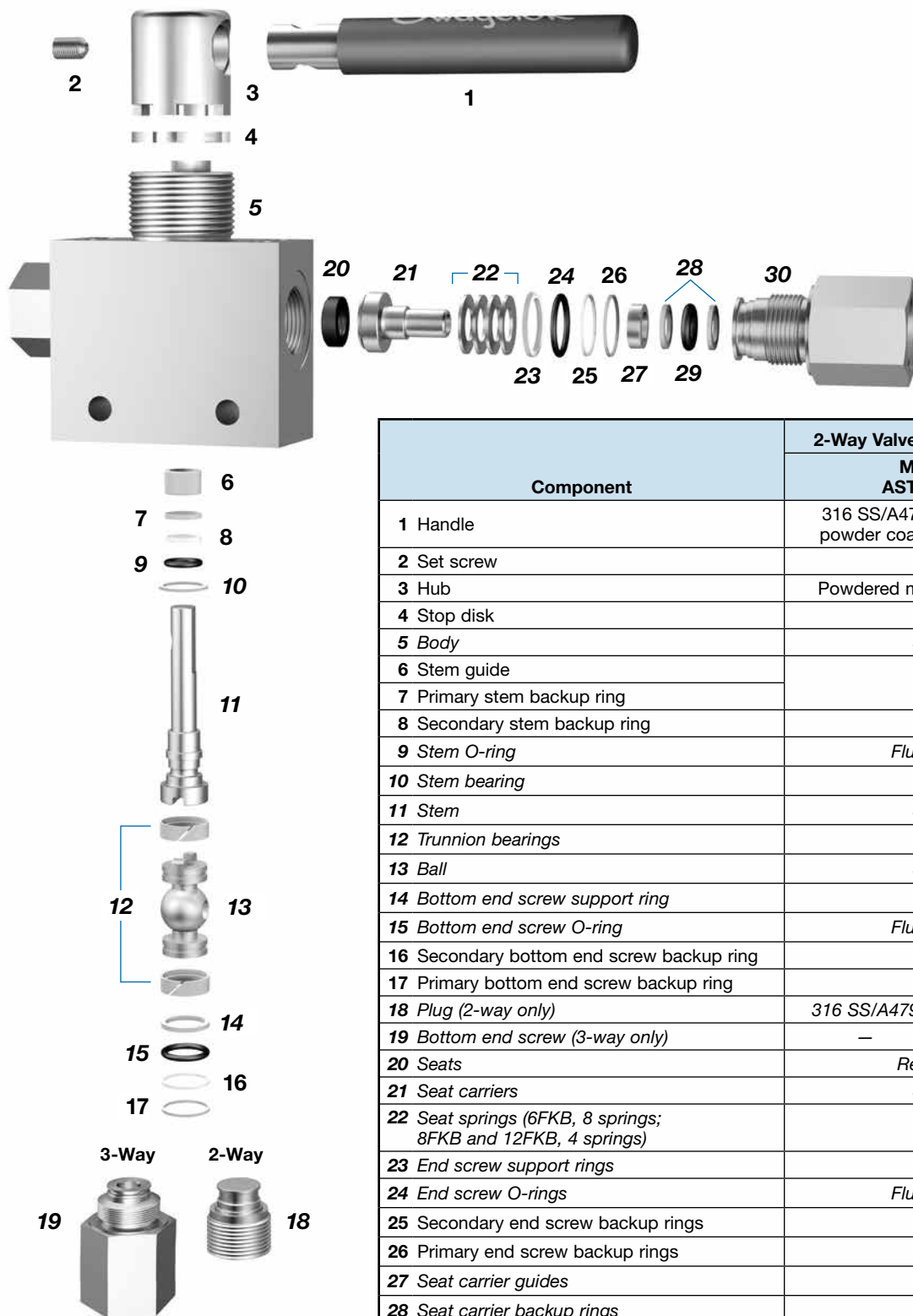

Component	2-Way Valve	3-Way Valve
	Material Grade/ ASTM Specification	
1 Handle	316 SS/A479 with blue electrostatic powder coating and white epoxy ink	
2 Set screw	316 SS/A276	
3 Hub	Powdered metal 300 series SS/B783	
4 Stop disk	316 SS/A276	
5 Body	316 SS/A479	
6 Stem guide	PEEK	
7 Primary stem backup ring	PEEK	
8 Secondary stem backup ring	PTFE	
9 Stem O-ring	<i>Fluorocarbon FKM</i>	
10 Stem bearing	PEEK	
11 Stem	316 SS/A479	
12 Trunnion bearings	PEEK	
13 Ball	316 SS/A276	
14 Bottom end screw support ring	PEEK	
15 Bottom end screw O-ring	<i>Fluorocarbon FKM</i>	
16 Secondary bottom end screw backup ring	PTFE	
17 Primary bottom end screw backup ring	PEEK	
18 Plug (2-way only)	316 SS/A479	—
19 Bottom end screw (3-way only)	—	316 SS/A479
20 Seats	<i>Reinforced PEEK</i>	
21 Seat carriers	316 SS/A276	
22 Seat springs (6FKB, 8 springs; 8FKB and 12FKB, 4 springs)	17-7PH/A673	
23 End screw support rings	PEEK	
24 End screw O-rings	<i>Fluorocarbon FKM</i>	
25 Secondary end screw backup rings	PTFE	
26 Primary end screw backup rings	PEEK	
27 Seat carrier guides	316 SS	
28 Seat carrier backup rings	PEEK	
29 Seat carrier O-rings	<i>Fluorocarbon FKM</i>	
30 End screws	316 SS/A479	
Wetted lubricants	<i>Silicone-based, tungsten disulfide and fluorinated-based</i>	
Nonwetted lubricants	Hydrocarbon-based	

Wetted components listed in *italics*.

MEDIUM- AND HIGH-PRESSURE

Testing

Every Swagelok FKB series medium-pressure ball valve is factory tested with nitrogen at 1000 psig (68.9 bar). Seats have a maximum allowable leak rate of 0.1 std cm³/min. Shell testing is performed to a requirement of no detectable leakage with a liquid leak detector.

Cleaning and Packaging

All Swagelok FKB series medium-pressure ball valves are cleaned and packaged in accordance with Swagelok *Standard Cleaning and Packaging (SC-10)* (MS-06-62), page 1174.

Ordering Information and Dimensions

Dimensions, in inches (millimeters), are for reference only and are subject to change.

Select an ordering number from the tables on the next two pages.

- Hardware for the Swagelok medium-pressure tube fitting end connections is not assembled on the valve but is included with the valve as a pre-assembled fitting cartridge.
- Hardware for the cone and thread fitting (collar and gland) end connections is included with valve.

2-Way (On-Off) Valve

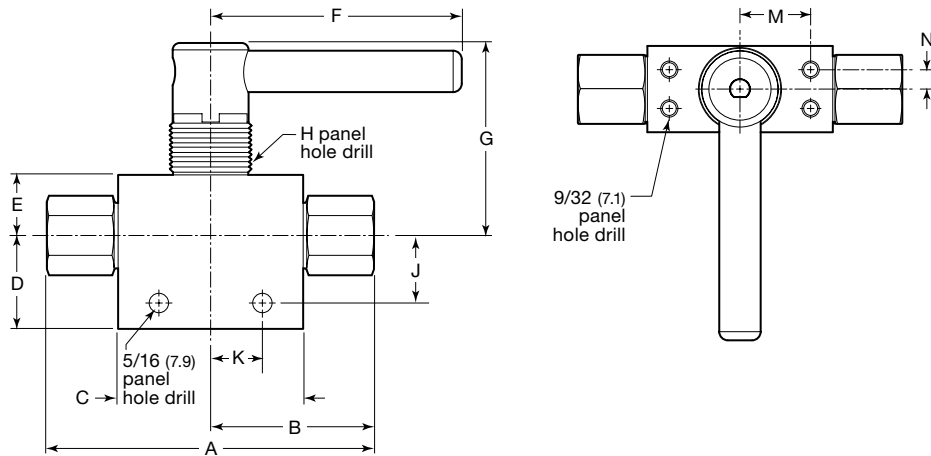

3-Way (Switching) Valve

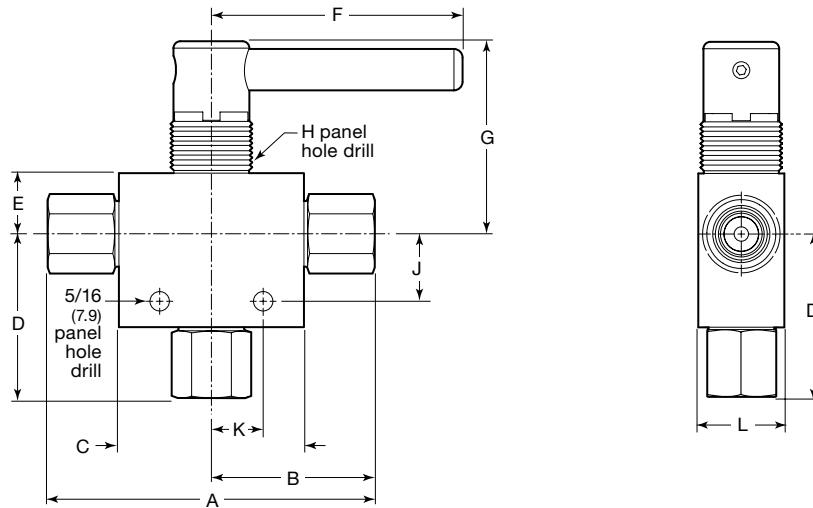

MEDIUM- AND HIGH-PRESSURE

Ordering Information and Dimensions

2-Way FKB Series Ball Valves

End Connections		Flow Coefficient (C _v)	Valve Ordering Number	Dimensions, in. (mm)												
Type	Size			A ^①	B ^①	C	D	E	F	G	H	J	K	L	M	N
6FKB Series On-Off (2-Way) Valves, 0.209 in. (5.31 mm) Orifice																
Swagelok medium-pressure tube fitting	1/4 in.	0.5	SS-6FKBFK4	4.08 (104)	2.04 (51.8)	2.68 (68.1)	1.35 (34.3)	0.88 (22.4)	3.65 (92.7)	2.78 (70.6)	1.25 (31.8)	0.97 (24.6)	0.75 (19.0)	1.25 (31.8)	1.02 (25.9)	0.28 (7.1)
	3/8 in.	1.5	SS-6FKBFK6	4.74 (120)	2.37 (60.2)											
	1/2 in.	1.4	SS-6FKBFK8	4.74 (120)	2.37 (60.2)											
Female NPT	1/4 in.	1.3	SS-6FKBF4	4.22 (107)	2.11 (53.6)											
	3/8 in.	1.1	SS-6FKBF6	4.34 (110)	2.17 (55.1)											
	1/2 in.	1.0	SS-6FKBF8	4.78 (121)	2.39 (60.7)											
Cone and thread	1/4 in.	0.26	SS-6FKBCT4	4.08 (104)	2.04 (51.8)											
	3/8 in.	1.0	SS-6FKBCT6	4.74 (120)	2.37 (60.2)											
8FKB Series On-Off (2-Way) Valves, 0.375 in. (9.52 mm) Orifice																
Swagelok medium-pressure tube fitting	1/2 in.	3.2	SS-8FKBFK8	5.81 (148)	2.90 (73.7)	3.75 (95.2)	1.95 (49.5)	1.18 (30.0)	4.49 (114)	3.07 (78.6)	1.56 (39.6)	1.57 (39.9)	1.00 (25.4)	1.75 (44.4)	1.55 (39.4)	0.38 (9.7)
	9/16 in.	3.2	SS-8FKBFK9													
Female NPT	1/2 in.	4.5	SS-8FKBF8	5.81 (148)	2.90 (73.7)											
Cone and thread	9/16 in.	2.2	SS-8FKBCT9	7.20 (183)	3.60 (91.4)											
12FKB Series On-Off (2-Way) Valves, 0.560 in. (14.2 mm) Orifice																
Swagelok medium-pressure tube fitting	3/4 in.	7.3	SS-12FKBFK12	7.38 (187)	3.69 (93.7)	4.58 (116)	2.30 (58.4)	1.33 (33.8)	4.46 (113)	3.48 (88.4)	1.56 (39.6)	1.85 (47.0)	1.44 (36.6)	2.00 (50.8)	1.55 (39.4)	0.38 (9.7)
Female NPT	3/4 in.	11	SS-12FKBF12	7.38 (187)	3.69 (93.7)											
Cone and thread	3/4 in.	6.5	SS-12FKBCT12	7.38 (187)	3.69 (93.7)											
	1 in.	9.0	SS-12FKBCT16	8.12 (206)	4.06 (103)											

① Dimensions do not include fitting hardware. See table below.

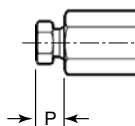

Size	Dimensions, in. (mm)	
	P FK Nut	P C&T Nut
20 000 psig (1378 bar)		
1/4 in.	0.47 (11.9)	0.38 (9.8)
3/8 in.	0.56 (14.2)	0.48 (12.2)
1/2 in.	0.57 (14.5)	—
9/16 in.	0.74 (18.8)	0.68 (17.3)
3/4 in.	0.93 (23.6)	0.59 (15.0)
1 in.	—	0.75 (18.8)
60 000 psig (4134 bar)		
1/4 in.	—	0.59 (15.0)
3/8 in.	—	0.72 (18.3)
9/16 in.	—	1.00 (25.4)

Ordering Information and Dimensions

3-Way FKBX Series Ball Valves

End Connections		Flow Coefficient (C _v)	Valve Ordering Number	Dimensions, in. (mm)												
Type	Size			A ^①	B ^①	C	D	E	F	G	H	J	K	L	M	N
6FKB Series Switching (3-Way) Valves, 0.209 in. (5.31 mm) Orifice																
Swagelok medium-pressure tube fitting	1/4 in.	0.44	SS-6FKBFXK4	5.03 (128)	2.52 (64.0)	2.68 (68.1)	2.05 (52.1)	0.88 (22.4)	3.65 (92.7)	2.78 (70.6)	1.25 (31.8)	0.97 (24.6)	0.75 (19.0)	1.25 (31.8)	1.02 (25.9)	0.28 (7.1)
	3/8 in.	0.98	SS-6FKBFXK6	5.87 (149)	2.94 (74.7)		2.38 (60.5)									
	1/2 in.	0.83	SS-6FKBFXK8	5.87 (149)	2.94 (74.7)		2.38 (60.5)									
Female NPT	1/4 in.	0.81	SS-6FKBFXF4	4.22 (107)	2.11 (53.6)	2.68 (68.1)	2.12 (53.8)	0.88 (22.4)	3.65 (92.7)	2.78 (70.6)	1.25 (31.8)	0.97 (24.6)	0.75 (19.0)	1.25 (31.8)	1.02 (25.9)	0.28 (7.1)
	3/8 in.	0.76	SS-6FKBFXF6	4.34 (110)	2.17 (55.1)		2.18 (55.4)									
	1/2 in.	0.73	SS-6FKBFXF8	4.78 (121)	2.39 (60.7)		2.40 (61.0)									
Cone and thread	1/4 in.	0.23	SS-6FKBFXCT4	5.03 (128)	2.52 (64.0)	2.68 (68.1)	2.05 (52.1)	0.88 (22.4)	3.65 (92.7)	2.78 (70.6)	1.25 (31.8)	0.97 (24.6)	0.75 (19.0)	1.25 (31.8)	1.02 (25.9)	0.28 (7.1)
	3/8 in.	0.75	SS-6FKBFXCT6	5.87 (149)	2.94 (74.7)		2.38 (60.5)									
8FKB Series Switching (3-Way) Valves, 0.375 in. (9.52 mm) Orifice																
Swagelok medium-pressure tube fitting	1/2 in.	2.0	SS-8FKBFXK8	7.20 (183)	3.60 (91.4)	3.75 (95.2)	3.00 (76.2)	1.18 (30.0)	4.49 (114)	3.07 (78.6)	1.56 (39.6)	1.57 (39.9)	1.00 (25.4)	1.75 (44.4)	1.55 (39.4)	0.38 (9.7)
	9/16 in.	2.2	SS-8FKBFXK9													
Female NPT	1/2 in.	2.7	SS-8FKBFXF8	5.81 (148)	2.90 (73.7)	3.75 (95.2)	3.00 (76.2)	1.18 (30.0)	4.49 (114)	3.07 (78.6)	1.56 (39.6)	1.57 (39.9)	1.00 (25.4)	1.75 (44.4)	1.55 (39.4)	0.38 (9.7)
Cone and thread	9/16 in.	2.2	SS-8FKBFXCT9	7.20 (183)	3.60 (91.4)											

① Dimensions do not include fitting hardware. See page 1053 for dimensions of Swagelok medium-pressure tube fittings; see page 1069 for dimensions of cone and thread fittings.

ISO 5211-Compliant Pneumatic Actuators

Swagelok ISO 5211-compliant rack and pinion pneumatic actuators are available in spring-return and double-acting modes. On-off (2-way) valves require 90° actuation; switching (3-way) valves require 180° actuation.

Swagelok can provide complete actuated ball valve assemblies—including valves, actuators, sensors, bracket kits, and solenoids—with interfaces that meet ISO 5211, NAMUR, and VDI/VDE 3845.

For technical data, including actuator materials of construction and weight, see the *Swagelok Ball Valve Actuation Options* catalog (MS-02-343), page 468.

For additional information on selecting and sizing ISO 5211-compliant actuators, see the *Actuated Ball Valve Selection Guide—ISO 5211-Compliant Actuator Mounting Bracket Kits* (MS-02-136), page 484.

⚠ Caution: Actuated assemblies must be properly aligned and supported. Improper alignment or inadequate support of the actuated assembly may result in leakage or premature valve failure.

Pressure-Temperature Ratings

Maximum actuator pressure is 116 psig (7.9 bar). See **Minimum Actuator Pressure** table below for minimum actuator pressures.

Actuator Service	Actuator Service Designator	Temperature Range °F (°C)
Standard	—	-40 to 176 (-40 to 80)
High temperature	HT	5 to 302 (-15 to 150)

Minimum Actuator Pressure

Actuator Model	Spring Return Model Designators		Double Acting Model Designator	Actuation Mode	
	Normally Closed	Normally Open		Spring Return	Double Acting
				Minimum Actuator Pressure, psig (bar)	
6FKB Series On-Off (2-Way) Valves					
A30 (90°)	—	—	-A30D	—	43 (3.0)
A60 (90°)	-A60C5	-A60O5	-A60D	72 (5.0)	36 (2.5)
6FKB Series Switching (3-Way) Valves					
A30 (180°)	—	—	-A30XD	—	43 (3.0)
A60 (180°)	—	—	-A60XD	—	36 (2.5)
8FKB Series On-Off (2-Way) Valves					
AF60 (90°)	—	—	-AF60D	—	84 (5.8)
A100 (90°)	-A100C6	-A100O6	-A100D	88 (6.1)	55 (3.8)
8FKB Series Switching (3-Way) Valves					
AF60 (180°)	—	—	-AF60XD	—	84 (5.8)
A100 (180°)	—	—	-A100XD	—	55 (3.8)
12FKB Series On-Off (2-Way) Valves					
A150 (90°)	—	—	-A150D	—	84 (5.8)
A220 (90°)	-A220C5	-A220O5	-A220D	80 (5.6)	51 (3.6)

ISO 5211-Compliant Pneumatic Actuators

Dimensions

Dimensions, in inches (millimeters), are for reference only and are subject to change.

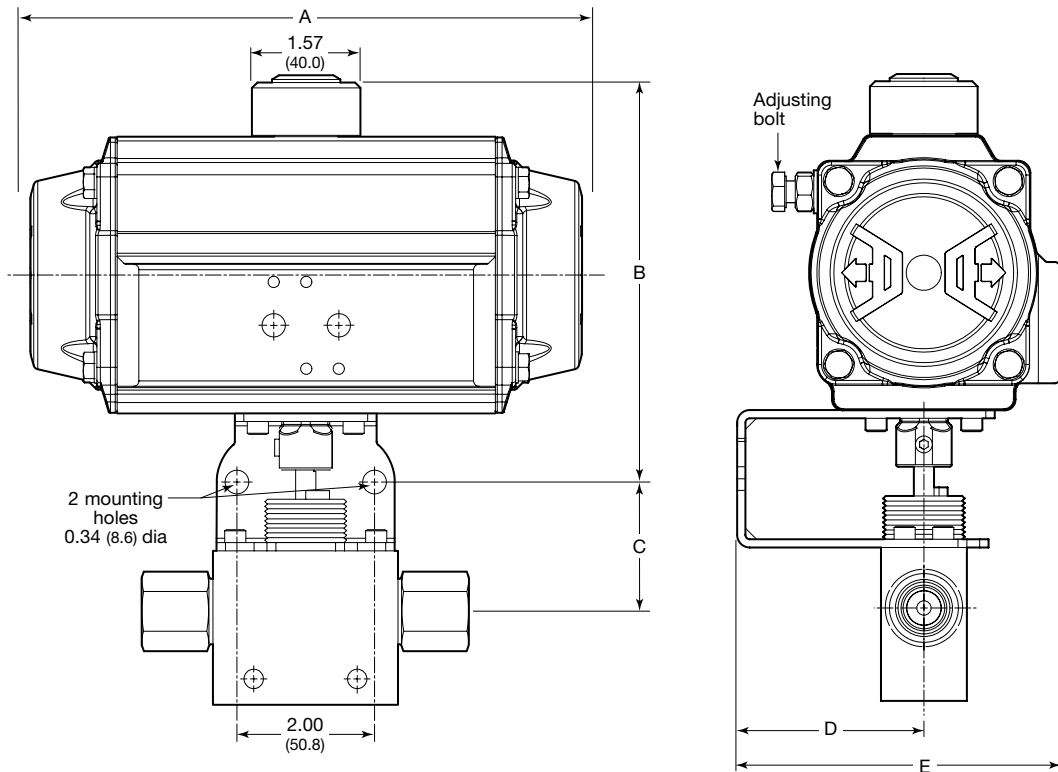

Actuator Model	Dimensions, in. (mm)				
	A	B	C	D	E
6FKB Series On-Off (2-Way) Valves					
A30 (90°)	6.04 (153)	5.24 (133)	1.88 (47.8)	2.72 (69.1)	4.63 (118)
A60 (90°)	8.01 (203)	5.91 (150)	1.88 (47.8)	2.72 (69.1)	4.71 (120)
6FKB Series Switching (3-Way) Valves					
A30 (180°)	8.50 (216)	5.24 (133)	1.88 (47.8)	2.72 (69.1)	4.63 (118)
A60 (180°)	11.4 (290)	5.91 (150)	1.88 (47.8)	2.72 (69.1)	4.71 (120)
8FKB Series On-Off (2-Way) Valves					
AF60 (90°)	8.01 (203)	6.06 (154)	2.16 (54.9)	2.87 (72.9)	4.86 (123)
A100 (90°)	9.41 (239)	6.57 (167)	2.16 (54.9)	2.87 (72.9)	5.09 (129)
8FKB Series Switching (3-Way) Valves					
AF60 (180°)	8.01 (203)	6.06 (154)	2.16 (54.9)	2.87 (72.9)	4.86 (123)
A100 (180°)	9.41 (239)	6.57 (167)	2.16 (54.9)	2.87 (72.9)	5.09 (129)
12FKB Series On-Off (2-Way) Valves					
A150 (90°)	10.2 (259)	7.04 (179)	2.31 (58.7)	2.87 (72.9)	5.35 (136)
A220 (90°) ^①	12.0 (305)	8.15 (207)	2.31 (58.7)	2.87 (72.9)	5.71 (145)

① The adjusting bolt extends beyond the mounting bracket, dimensions D and E. Shims may be required for proper installation.

ISO 5211-Compliant Pneumatic Actuators

Ordering Information

Factory-Assembled Valves with Actuators

Typical Ordering Number

A B C
SS-6FKBFK8 -A60C5 HT

A Valve Ordering Number

B Actuator Model

Based on actuation mode and flow pattern, select actuator designator. See **Minimum Actuator Pressure** table, page 1117.

C Actuator Service

HT = High temperature
None = Standard

Kits for Field Assembly

Order one actuator kit and one mounting bracket kit for each valve.

Actuator Kit Typical Ordering Number

A B C
MS - A60-DA - DIN -HT

A Actuator Model

Based on actuation mode and flow pattern, select actuator designator. See **Minimum Actuator Pressure** table, page 1117, and **Actuator Model Designators** table below.

B Coupling Drive Type

DIN

C Actuator Service

-HT = High temperature
None = Standard

Actuator Model Designators

Actuator Model	Spring Return Model Designator	Double Acting Model Designator
6FKB Series On-Off (2-Way) Valves		
A30 (90°)	—	A30-DA
A60 (90°)	A60S5	A60-DA
6FKB Series Switching (3-Way) Valves		
A30 (180°)	—	A30-XDA
A60 (180°)	—	A60-XDA
8FKB Series On-Off (2-Way) Valves		
AF60 (90°)	—	AF60-DA
A100 (90°)	A100S6	A100-DA
8FKB Series Switching (3-Way) Valves		
AF60 (180°)	—	A60-XDA
A100 (180°)	—	A100-XDA
12FKB Series On-Off (2-Way) Valves		
A150 (90°)	—	A150-DA
A220 (90°)	A220S5	A220-DA

Mounting Bracket Kits

Swagelok ISO 5211 mounting bracket kits contain:

- 316 stainless steel mounting bracket
- Eight 316 stainless steel socket head cap screws
- Powdered metal 300 series stainless steel coupling
- 316 stainless steel set screw
- Instructions.

Valve Series	Kit Ordering Number
6FKB	SS-MB-6FKB-F05-14DIN-M
8FKB	SS-MB-8FKB-F07-17DIN-M
12FKB	SS-MB-12FKB-F07-17DIN-M

Options for Pneumatic Actuators

For Field Assembly or Factory Assembly

■ Solenoid Valves

attach to the actuator to create an electropneumatically actuated ball valve assembly.

■ Position Indicators

provide visual status of a valve.

■ Limit Switches

indicate actuator position by means of an electrical signal. They meet a variety of NEMA ratings such as NEMA 4 (weatherproof) and NEMA 7 (explosion proof).

All electrical components listed above meet North American NEMA and European CE/ CENELEC requirements. Contact your authorized Swagelok representative for ordering information.

See the Swagelok *Ball Valve Actuation Options* catalog (MS-02-343), page 468 for more information on solenoid valves, position indicators, and limit switches.

Options

Handle Colors

Stainless steel bar handles with blue electrostatic powder coating are standard. Other colors are available.

To order, add a handle color designator to the valve ordering number.

Example:

SS-6FKBFK4-BK

Handle Color	Designator
Black	-BK
Green	-GR
Orange	-OR
Red	-RD
Yellow	-YW

Options

O-Ring Materials

Optional O-ring materials are available for all FKB series ball valves shown below. To order, add the optional O-ring material designator to the valve ordering number.

Examples:

Optional HNBR O-ring: SS-6FKBFK4-H

Optional perfluorocarbon FFKM O-ring: SS-6FKBFK4-C

O-Ring Material	Temperature Rating °F (°C)	Designator
HNBR	0 (-17) to 250 (121)	-H
Perfluorocarbon FFKM	20 (-6) to 185 (85)	-C

Accessories

Locking Handle Kits

Locking handle kits are available. Each kit contains a 316 stainless steel locking bracket, bracket screws, locking stop disk, and instructions.

Panel Nut Kits

Panel nut kits are available for manual valves. Panel thickness minimum is 0.12 in. (3.1 mm); maximum is 0.50 in. (12.7 mm). Each kit contains a 316 stainless steel panel nut and instructions.

Cap Screw Kits

Cap screw kits are available for panel mounting manual valve body shoulders to a panel 0.125 in. (3.2 mm) thick. Each kit contains four 1/4-20, 3/8 in. (9.5 mm) long 316 stainless steel cap screws and instructions.

Stop Disk Kits

Replacement stop disk kits are available. Each kit contains a replacement stop disk and instructions.

End Screw Kits

End screw kits are supplied fully assembled and ready for installation after adding lubricant according to the included maintenance instructions.

- If the valve stem or ball have damage, the entire valve must be replaced.
- End screw kits do not include fitting hardware.

To order, add the end connection designator to the desired end screw kit basic ordering number.

Example: SS-1CSK-6FKB-6FK

Valve Series	Valve Flow Path	Ordering Numbers			
		Locking Handle Kits	Panel Nut Kits	Cap Screw Kits	Stop Disk Kits
6FKB	2-way	SS-5DK-6FKB-LH	SS-7K-6FKB	SS-6SCK-0882	SS-5DK-6FKB
	3-way	SS-5DK-6FKBX-LH			SS-5DK-6FKBX
8FKB	2-way	SS-5DK-8FKB-LH	SS-7K-8FKB	SS-6SCK-0882	SS-5DK-8FKB
	3-way	SS-5DK-8FKBX-LH			SS-5DK-8FKBX
12FKB	2-way	SS-5DK-12FKB-LH	SS-7K-8FKB	SS-6SCK-0882	SS-5DK-12FKB

End Screw Kits

Valve Series	Valve Flow Path	Port Location	Basic Ordering Number
6FKB	2-way 3-way	Side	SS-1CSK-6FKB-
	3-way	Bottom	SS-1CBSK-6FKB-
8FKB	2-way 3-way	Side	SS-1CSK-8FKB-
	3-way	Bottom	SS-1CBSK-8FKB-
12FKB	2-way	Side	SS-1CSK-12FKB-

End Connection		
Style	Size in.	Designator
Swagelok medium pressure tube fitting	1/4	4FK
	3/8	6FK
	1/2	8FK
	9/16	9FK
	3/4	12FK
Female NPT	1/4	F4
	3/8	F6
	1/2	F8
	3/4	F12

End Connection		
Style	Size in.	Designator
Cone and thread	1/4	4CT
	3/8	6CT
	1/2	8CT
	3/4	12CT
	1	16CT

Medium-Pressure Trunion-Style Ball Valves— IPT series

Pressures up to 20 000 psig (1378 bar)



- Pressure ratings up to 20 000 psig (1378 bar)
- Temperatures up to 250°F (121°C)
- 316 stainless steel construction
- Three valve series / orifices sizes: 0.188 in. (4.78 mm), 0.250 in. (6.35 mm), 0.375 in. (9.52 mm)
- End connection sizes: 1/4 to 1 in.
- 2-way (on-off) and 3-way (switch / divert) flow patterns

Features

IPT series trunion-style ball valves offer low-torque, quarter-turn operation in a compact design providing positive shutoff in applications up to 20 000 psig (1378 bar). Other features include:

- 2-way valves—bidirectional; 3-way valves—common bottom inlet port.
- Female NPT and cone and thread end connections.
- Three mounting options include:
 - Panel mount using panel nut
 - Two bolts through panel into top of valve body
 - Bolted through body mounting holes with dual bolt pattern for OEM valve replacement.
- Available for sour gas applications. Materials are selected in accordance with NACE MR0175/ISO15156.

Pressure-Temperature Ratings

Temperature °F (°C)	316 Stainless Steel with Fluorocarbon FKM O-Rings
	Working Pressure, psig (bar) ^{①②}
0 (-17) to 250 (121)	20 000 (1378)

① Working pressure determined based on ASME B31.3 Process Piping, Chapter IX High Pressure Piping.

② Pressure ratings may derate based upon the chosen end connection.

Important Information About Ball Valves

- ⚠ **Swagelok ball valves are designed to be used in a fully open or fully closed position.**
- ⚠ **Valves that have not been cycled for a period of time may have a higher initial actuation torque.**
- ⚠ **To avoid damage and over-actuation, do not attempt to actuate past positive stop**
- ⚠ **3-way valves not intended for use as side inlet.**

Directional handle

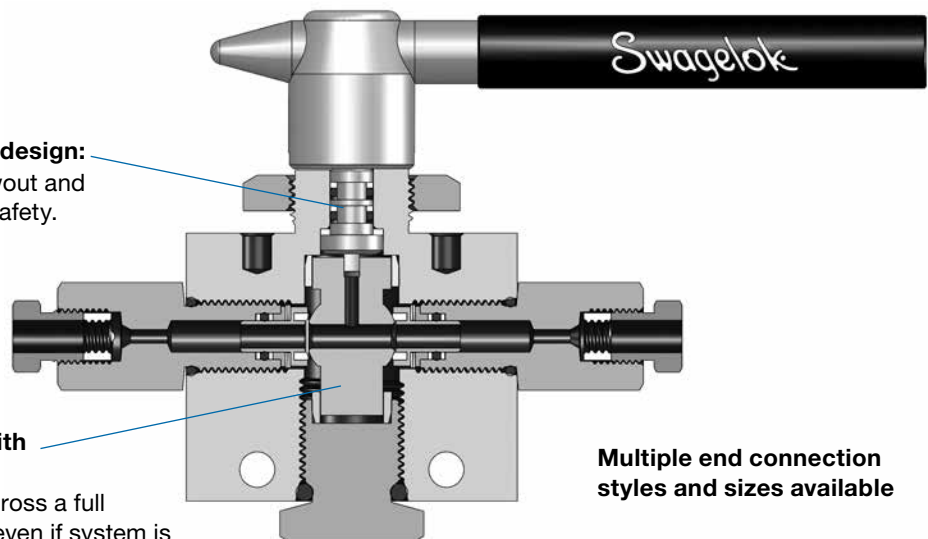

Bottom-loaded stem design:

- eliminates stem blowout and enhances operator safety.

Trunion-style ball with direct-load design:

- seals consistently across a full range of pressures, even if system is depressurized and repressurized
- ensures reliable operation for improved actuation of control systems.

Multiple end connection styles and sizes available

Materials of Construction

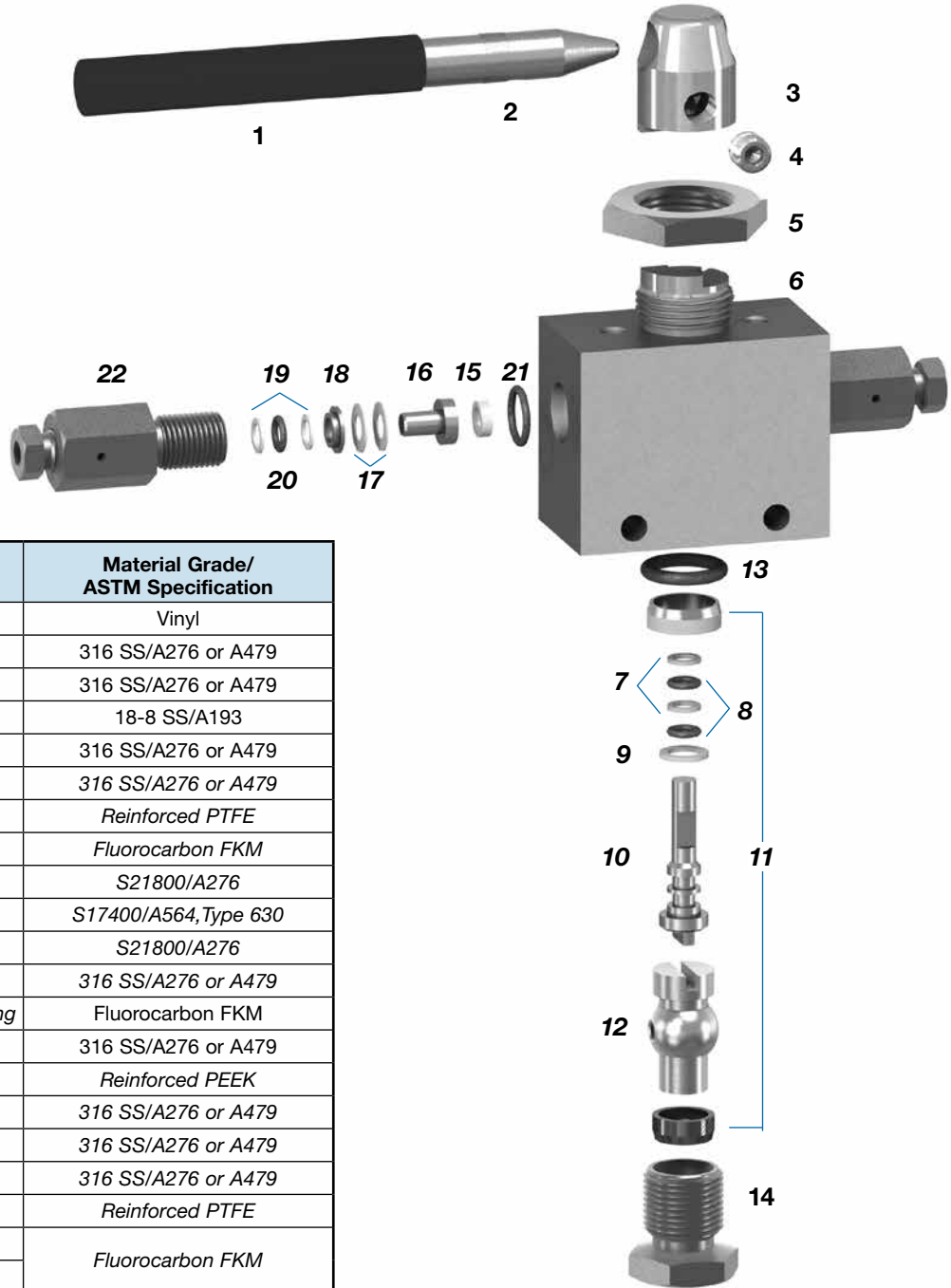

Component	Material Grade/ ASTM Specification
1 Handle sleeve	Vinyl
2 Handle	316 SS/A276 or A479
3 Hub	316 SS/A276 or A479
4 Set screw	18-8 SS/A193
5 Panel nut	316 SS/A276 or A479
6 Body	316 SS/A276 or A479
7 Backup washer	<i>Reinforced PTFE</i>
8 O-ring	<i>Fluorocarbon FKM</i>
9 Bearing washer	<i>S21800/A276</i>
10 Stem	<i>S17400/A564, Type 630</i>
11 Trunnion bearing	<i>S21800/A276</i>
12 Ball	316 SS/A276 or A479
13 Bottom end screw O-ring	Fluorocarbon FKM
14 Plug	316 SS/A276 or A479
15 Seat	<i>Reinforced PEEK</i>
16 Seat carrier	316 SS/A276 or A479
17 Seat springs	316 SS/A276 or A479
18 Follower	316 SS/A276 or A479
19 Backup washer	<i>Reinforced PTFE</i>
20 O-ring	<i>Fluorocarbon FKM</i>
21 Seat carrier O-ring	
22 End screw	316 SS/A276 or A479
Lubricants	<i>Fluorinated, PTFE-based and silicone-based</i>

Wetted components listed in *italics*.

Shown with cone and thread end connections

Testing

Every IPT series trunnion ball valve is factory tested with water at the maximum working pressure for 60 seconds. Shell and seat testing is performed to a requirement of no visible leakage.

Cleaning and Packaging

All IPT series trunnion ball valves are cleaned and packaged in accordance with Swagelok *Standard Cleaning and Packaging (SC-10)* (MS-06-62), page 1174.

Ordering Information and Dimensions

Dimensions, in inches (millimeters), are for reference only and are subject to change.

2-Way (On-Off) Valve

Orifice Size in. (mm)	Orifice Designator
0.188 (4.78)	L
0.250 (6.35)	M
0.375 (9.52)	N

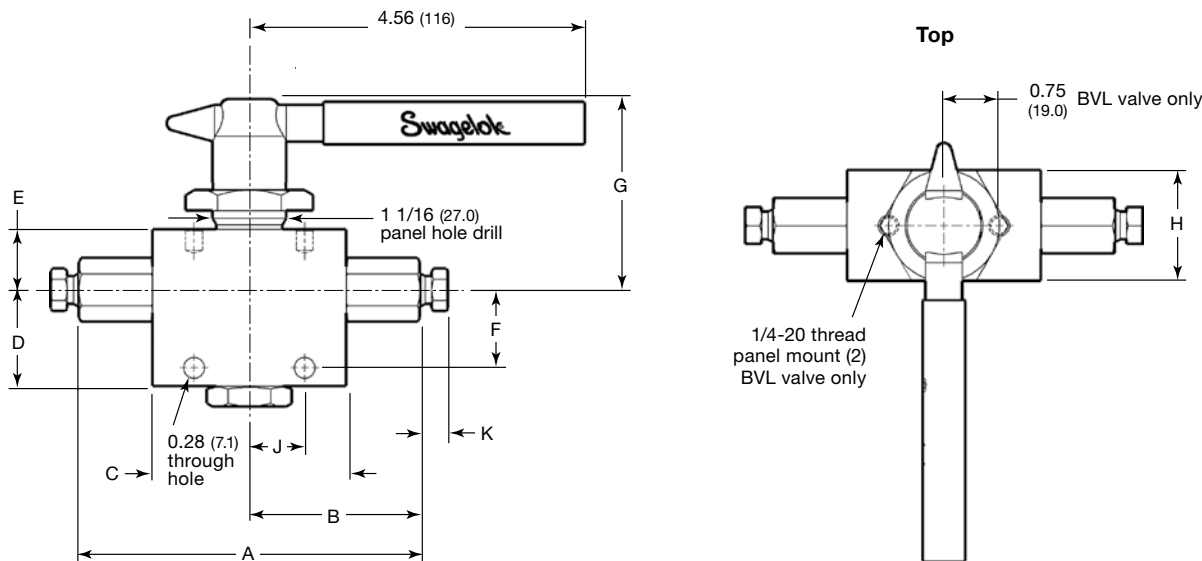

BVL—0.188 in. Orifice

End Connections		Ordering Number	Dimensions, in. (mm)									
Inlet/Outlet	Size		A	B	C	D	E	F	G	H	J	K
10 000 psig (689 bar)												
Female NPT	3/4 in.	BVLT-12NF-12NF	4.88 (124)	2.44 (62.0)	2.63 (66.8)	1.58 (40.1)	0.82 (20.8)	1.05 (26.7)	2.58 (65.5)	1.50 (38.1)	0.75 (19.0)	—
	1 in.	BVLT-16NF-16NF	5.28 (134)	2.64 (67.1)								
15 000 psig (1034 bar)												
Female NPT	1/4 in.	BVLT-4NF-4NF	4.63 (118)	2.31 (58.7)	2.63 (66.8)	1.58 (40.1)	0.82 (20.8)	1.05 (26.7)	2.58 (65.5)	1.50 (38.1)	0.75 (19.0)	—
	3/8 in.	BVLT-6NF-6NF	4.63 (118)	2.31 (58.7)								
	1/2 in.	BVLT-8NF-8NF	4.89 (124)	2.44 (62.0)								
20 000 psig (1378 bar)												
Cone and thread	1/4 in.	BVLT-4MF-4MF	4.63 (118)	2.32 (58.9)	2.63 (66.8)	1.58 (40.1)	0.82 (20.8)	1.05 (26.7)	2.58 (65.5)	1.50 (38.1)	0.75 (19.0)	0.38 (9.7)
	3/8 in.	BVLT-6MF-6MF	4.63 (118)	2.32 (58.9)								0.48 (12.2)
	9/16 in.	BVLT-9MF-9MF	5.13 (130)	2.56 (65)								0.68 (17.3)
	3/4 in.	BVLT-12MF-12MF	5.66 (144)	2.83 (71.9)								0.59 (15.0)
	1 in.	BVLT-16MF-16MF	5.96 (151)	2.98 (75.7)								0.74 (18.8)

MEDIUM- AND HIGH-PRESSURE

Ordering Information and Dimensions

Dimensions, in inches (millimeters), are for reference only and are subject to change.

BVM—0.250 in. Orifice

End Connections		Ordering Number	Dimensions, in. (mm)									
Inlet/Outlet	Size		A	B	C	D	E	F	G	H	J	K
10 000 psig (689 bar)												
Female NPT	3/4 in.	BVMT-12NF-12NF	4.78 (121)	2.39 (60.7)	2.38 (60.5)	1.37 (34.8)	0.75 (19.0)	0.75 (19.0)	2.51 (63.8)	1.50 (38.1)	0.88 (22.4)	—
	1 in.	BVMT-16NF-16NF	5.28 (134)	2.64 (67.1)								
15 000 psig (1034 bar)												
Female NPT	1/4 in.	BVMT-4NF-4NF	4.58 (116)	2.29 (58.2)	2.38 (60.5)	1.37 (34.8)	0.75 (19.0)	0.75 (19.0)	2.51 (63.8)	1.50 (38.1)	0.88 (22.4)	—
	3/8 in.	BVMT-6NF-6NF	4.58 (116)	2.29 (58.2)								
	1/2 in.	BVMT-8NF-8NF	4.84 (123)	2.42 (61.5)								
20 000 psig (1378 bar)												
Cone and thread	1/4 in.	BVMT-4MF-4MF	4.58 (116)	2.29 (58.2)	2.38 (60.5)	1.37 (34.8)	0.75 (19.0)	0.75 (19.0)	2.51 (63.8)	1.50 (38.1)	0.88 (22.4)	0.38 (9.7)
	3/8 in.	BVMT-6MF-6MF	4.58 (116)	2.29 (58.2)								0.48 (12.2)
	9/16 in.	BVMT-9MF-9MF	4.84 (123)	2.42 (61.5)								0.68 (17.3)
	3/4 in.	BVMT-12MF-12MF	4.80 (122)	2.40 (61.0)								0.59 (15.0)
	1 in.	BVMT-16MF-16MF	5.10 (130)	2.55 (64.8)								0.74 (18.8)

BVN—0.375 in. Orifice

End Connections		Ordering Number	Dimensions, in. (mm)									
Inlet/Outlet	Size		A	B	C	D	E	F	G	H	J	K
10 000 psig (689 bar)												
Female NPT	3/4 in.	BVNT-12NF-12NF	5.79 (147)	2.90 (73.7)	3.62 (91.9)	1.80 (45.7)	1.00 (25.4)	1.13 (28.7)	2.76 (70.1)	1.75 (44.4)	1.00 (25.4)	—
	1 in.	BVNT-16NF-16NF	6.54 (166)	3.27 (83.1)								
15 000 psig (1034 bar)												
Female NPT	1/4 in.	BVNT-4NF-4NF	5.60 (142)	2.80 (71.1)	3.62 (91.9)	1.80 (45.7)	1.00 (25.4)	1.13 (28.7)	2.76 (70.1)	1.75 (44.4)	1.00 (25.4)	—
	3/8 in.	BVNT-6NF-6NF	5.60 (142)	2.80 (71.1)								—
	1/2 in.	BVNT-8NF-8NF	5.59 (142)	2.80 (71.1)								—
20 000 psig (1378 bar)												
Cone and thread	1/4 in.	BVNT-4MF-4MF	5.54 (141)	2.77 (70.4)	3.62 (91.9)	1.80 (45.7)	1.00 (25.4)	1.13 (28.7)	2.76 (70.1)	1.75 (44.4)	1.00 (25.4)	0.38 (9.7)
	3/8 in.	BVNT-6MF-6MF	5.69 (145)	2.84 (72.1)								0.48 (12.2)
	9/16 in.	BVNT-9MF-9MF	6.21 (158)	3.10 (78.7)								0.68 (17.3)
	3/4 in.	BVNT-12MF-12MF	6.63 (168)	3.32 (84.3)								0.59 (15.0)
	1 in.	BVNT-16MF-16MF	7.44 (189)	3.72 (94.5)								0.74 (18.8)

Ordering Information and Dimensions





Dimensions, in inches (millimeters), are for reference only and are subject to change.

3-Way (Switch/Divert) Valves

Select a basic valve ordering number with the desired end connection size and style. Insert the desired flow path designator, **S** or **D** as shown.

Examples:

- 3-way valve with switching flow path:
BVLS-4NF-4NF-4NF
- 3-way valve with divert flow path:
BVMD-6MF-6MF-6MF

Flow Path Designator				
Description	Flow Path		Handle Rotation	Designator
On-Off Switching Service			180°	S
Divert Service			90°	D

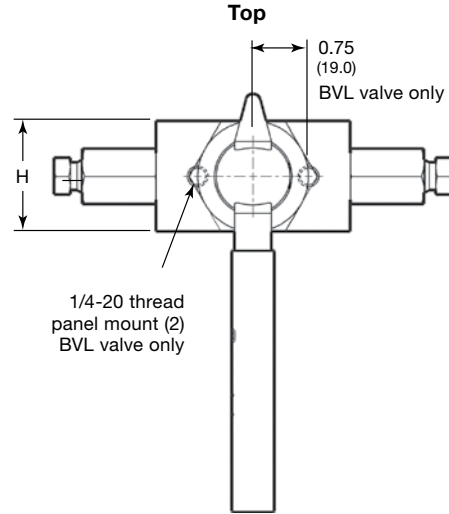
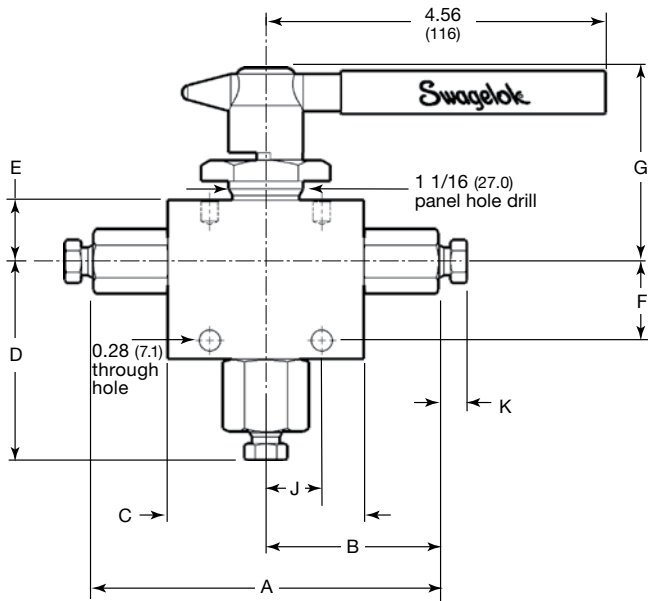

BVL—0.188 in. Orifice

End Connections		Basic Ordering Number	Dimensions, in. (mm)									
Inlet/Outlet	Size		A	B	C	D	E	F	G	H	J	K
10 000 psig (689 bar)												
Female NPT	3/4 in.	BVL_-12NF-12NF-12NF	4.88 (124)	2.44 (62.0)	2.63 (66.8)	2.45 (62.2)	0.82 (20.8)	1.05 (26.7)	2.58 (65.5)	1.50 (38.1)	0.75 (19.0)	—
	1 in.	BVL_-16NF-16NF-16NF	5.28 (134)	2.64 (67.1)		2.70 (68.6)						
15 000 psig (1034 bar)												
Female NPT	1/4 in.	BVL_-4NF-4NF-4NF	4.63 (118)	2.31 (58.7)	2.63 (66.8)	2.26 (57.4)	0.82 (20.8)	1.05 (26.7)	2.58 (65.5)	1.50 (38.1)	0.75 (19.0)	—
	3/8 in.	BVL_-6NF-6NF-6NF	4.63 (118)	2.31 (58.7)		2.32 (58.9)						
	1/2 in.	BVL_-8NF-8NF-8NF	4.89 (124)	2.44 (62.0)		2.41 (61.2)						
20 000 psig (1378 bar)												
Cone and thread	1/4 in.	BVL_-4MF-4MF-4MF	4.63 (118)	2.32 (58.9)	2.63 (66.8)	2.27 (57.7)	0.82 (20.8)	1.05 (26.7)	2.58 (65.5)	1.50 (38.1)	0.75 (19.0)	0.38 (9.7)
	3/8 in.	BVL_-6MF-6MF-6MF	4.63 (118)	2.32 (58.9)		2.28 (57.9)						0.48 (12.2)
	9/16 in.	BVL_-9MF-9MF-9MF	5.13 (130)	2.56 (65)		2.12 (53.8)						0.68 (17.3)
	3/4 in.	BVL_-12MF-12MF-12MF	5.66 (144)	2.83 (71.9)		2.51 (63.8)						0.59 (15.0)
	1 in.	BVL_-16MF-16MF-16MF	5.96 (151)	2.98 (75.7)		2.66 (67.6)						0.74 (18.8)

Ordering Information and Dimensions

Dimensions, in inches (millimeters), are for reference only and are subject to change.

BVM—0.250 in. Orifice

End Connections		Basic Ordering Number	Dimensions, in. (mm)									
Inlet/Outlet	Size		A	B	C	D	E	F	G	H	J	K
10 000 psig (689 bar)												
Female NPT	3/4 in.	BVM_-12NF-12NF-12NF	4.78 (121)	2.39 (60.7)	2.38 (60.5)	2.27 (57.7)	0.75 (19.0)	0.75 (19.0)	2.51 (63.8)	1.50 (38.1)	0.88 (22.4)	—
	1 in.	BVM_-16NF-16NF-16NF	5.28 (134)	2.64 (67.1)		2.52 (64.0)						—
15 000 psig (1034 bar)												
Female NPT	1/4 in.	BVM_-4NF-4NF-4NF	4.58 (116)	2.29 (58.2)	2.38 (60.5)	2.12 (53.8)	0.75 (19.0)	0.75 (19.0)	2.51 (63.8)	1.50 (38.1)	0.88 (22.4)	—
	3/8 in.	BVM_-6NF-6NF-6NF	4.58 (116)	2.29 (58.2)		2.12 (53.8)						—
	1/2 in.	BVM_-8NF-8NF-8NF	4.84 (123)	2.42 (61.5)		2.37 (60.2)						—
20 000 psig (1378 bar)												
Cone and thread	1/4 in.	BVM_-4MF-4MF-4MF	4.58 (116)	2.29 (58.2)	2.38 (60.5)	2.12 (53.8)	0.75 (19.0)	0.75 (19.0)	2.51 (63.8)	1.50 (38.1)	0.88 (22.4)	0.38 (9.7)
	3/8 in.	BVM_-6MF-6MF-6MF	4.58 (116)	2.29 (58.2)		2.12 (53.8)						0.48 (12.2)
	9/16 in.	BVM_-9MF-9MF-9MF	4.84 (123)	2.42 (61.5)		2.25 (57.2)						0.68 (17.3)
	3/4 in.	BVM_-12MF-12MF-12MF	4.80 (122)	2.40 (61.0)		2.28 (57.9)						0.59 (15.0)
	1 in.	BVM_-16MF-16MF-16MF	5.10 (130)	2.55 (64.8)		2.43 (61.7)						0.74 (18.8)

BVN—0.375 in. Orifice

End Connections		Basic Ordering Number	Dimensions, in. (mm)									
Inlet/Outlet	Size		A	B	C	D	E	F	G	H	J	K
10 000 psig (689 bar)												
Female NPT	3/4 in.	BVN_-12NF-12NF-12NF	5.79 (147)	2.90 (73.7)	3.62 (91.1)	2.53 (64.3)	1.00 (25.4)	1.13 (28.7)	2.76 (70.1)	1.75 (44.4)	1.00 (25.4)	—
	1 in.	BVN_-16NF-16NF-16NF	6.54 (166)	3.27 (83.1)		2.88 (73.2)						—
15 000 psig (1034 bar)												
Female NPT	1/4 in.	BVN_-4NF-4NF-4NF	5.60 (142)	2.80 (71.1)	3.62 (91.1)	2.41 (61.2)	1.00 (25.4)	1.13 (28.7)	2.76 (70.1)	1.75 (44.4)	1.00 (25.4)	—
	3/8 in.	BVN_-6NF-6NF-6NF	5.60 (142)	2.80 (71.1)		2.41 (61.2)						—
	1/2 in.	BVN_-8NF-8NF-8NF	5.59 (142)	2.80 (71.1)		2.41 (61.2)						—
20 000 psig (1378 bar)												
Cone and thread	1/4 in.	BVN_-4MF-4MF-4MF	5.54 (141)	2.77 (70.4)	3.62 (91.1)	2.14 (54.4)	1.00 (25.4)	1.13 (28.7)	2.76 (70.1)	1.75 (44.4)	1.00 (25.4)	0.38 (9.7)
	3/8 in.	BVN_-6MF-6MF-6MF	5.69 (145)	2.84 (72.1)		2.41 (61.2)						0.48 (12.2)
	9/16 in.	BVN_-9MF-9MF-9MF	6.21 (158)	3.10 (78.7)		2.41 (61.2)						0.68 (17.3)
	3/4 in.	BVN_-12MF-12MF-12MF	6.63 (168)	3.32 (84.3)		2.53 (64.3)						0.59 (15.0)
	1 in.	BVN_-16MF-16MF-16MF	7.44 (189)	3.72 (94.5)		2.79 (70.9)						0.74 (18.8)

Maintenance Kits

For maintenance kit information, contact your authorized Swagelok representative.

Subsea Service Ball Valves—IPT Series

For Pressures up to
15 000 psig (1034 bar)



- Pressure ratings up to 15 000 psig (1034 bar)
- Temperature range from 0 to 250°F (-17 to 121°C)
- 316 stainless steel construction
- Three valve/orifice sizes:
0.25 in. (6.4 mm)
0.38 in. (9.7 mm)
0.47 in. (11.9 mm)
- End connection sizes: 1/4 to 1 in.
- End connection styles: medium-pressure cone and thread (C&T), Swagelok medium-pressure tube fitting (FK), and female NPT

Bottom-loaded stem design:

- eliminates stem blowout and enhances operator safety.

Trunnion-style ball with direct-load design:

- seals consistently across a full range of pressures, even if system is depressurized and repressurized
- ensures reliable operation for improved actuation of control systems.

Features

- Bi-directional, 2-way trunnion-style valves
- Double barrier stem seal
- Single barrier end screw seal
- Quarter-turn operation
- ROV actuation
- Designed for workover applications
- Available for sour gas applications. Materials are selected in accordance with NACE MR0175/ISO15156.

Pressure-Temperature Ratings

Temperature °F (°C)	316 Stainless Steel with Fluorocarbon FKM O-Rings	
	Valve/ Orifice Size in. (mm)	Working Pressure psig (bar) ^①
0 (-17) to 250 (121)	0.25 (6.4)	15 000 (1034)
	0.38 (9.7)	10 000 (689)
	0.47 (11.9)	

① Working pressure determined based on ASME B31.3 Process Piping, Chapter IX High Pressure Piping. Working pressure ratings for NACE-compliant valves are 50 % of ratings in table.

② Pressure ratings may derate based upon the chosen end connection.

Important Information About Ball Valves

- ⚠ **Swagelok ball valves are designed to be used in a fully open or fully closed position.**
- ⚠ **Valves that have not been cycled for a period of time may have a higher initial actuation torque.**
- ⚠ **Do not exceed maximum torque values shown on “Actuation Torque” on page 1128.**
- ⚠ **Not designed for permanent use or fixed subsea applications.**

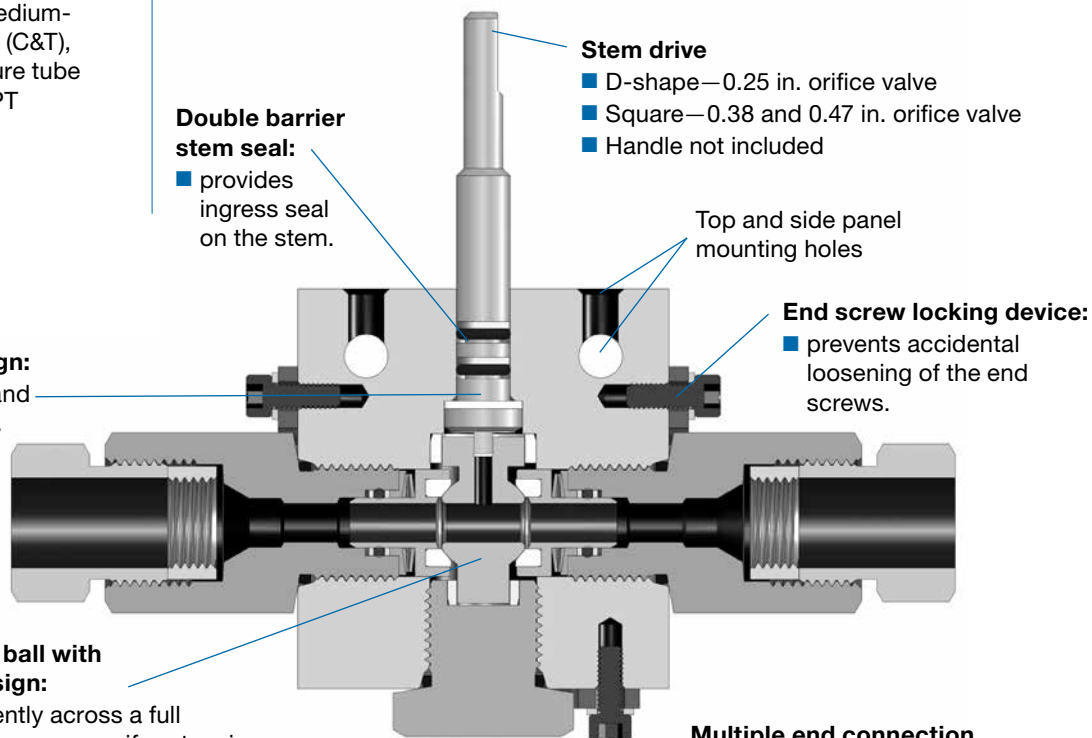

Shown: 0.25 in. orifice valve

Materials of Construction

Component	Material Grade/ ASTM Specification
1 End adapter	316 SS/A276 or A479
2 O-ring	Fluorocarbon FKM
3 End screw backup ring	Reinforced PEEK
4 O-ring	Fluorocarbon FKM
5 Follower	316 SS/A276 or A479
6 Spring washer	Standard—301 SS/A666 NACE—N07718/B637 or B670
7 Seat retainer	316 SS/A276 or A479
8 Seat seal	Reinforced PEEK
9 Cap screw	316 SS
10 Lock washer	316 SS/ASME B18
11 Locking device	316 SS/ASME B18
12 Body	316 SS/A276 or A479
13 Upper bearing	S21800/A276
14 Stem backup ring	Reinforced PTFE
15 O-ring	Fluorocarbon FKM
16 Bearing washer	S21800/A276
17 Stem	N06625/B443 or B446
18 Ball	316 SS/A276 or A479
19 Lower bearing	S21800/A276
20 O-ring	Fluorocarbon FKM
21 Plug	316 SS/A276 or A479
Wetted lubricants	Silicone-based with tungsten disulfide additive
Nonwetted lubricants	Hydrocarbon-based

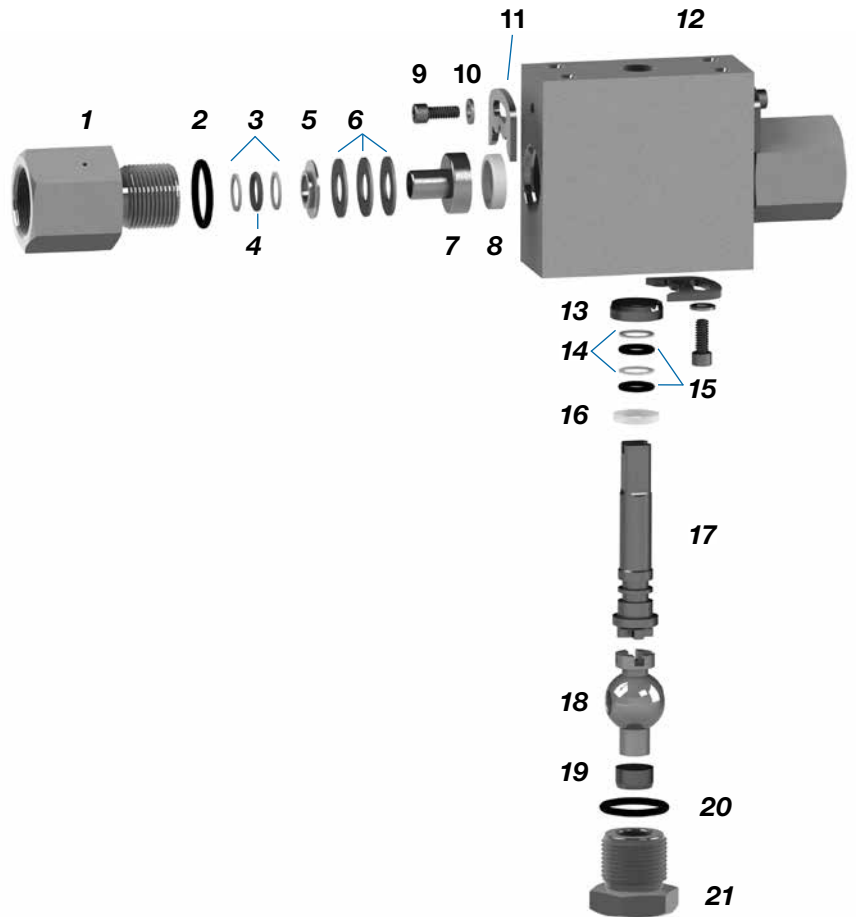

Wetted components listed in *italics*.

Testing

Every IPT series subsea service ball valve is factory tested with water at the maximum working pressure internally for 60 seconds. Shell and seat testing is performed to a requirement of no visible leakage.

Cleaning and Packaging

All IPT series subsea service ball valves are cleaned and packaged in accordance with Swagelok *Standard Cleaning and Packaging (SC-10)* (MS-06-62), page 1174.

Actuation Torque

Depending on stem adapter design, torque value may vary.

Valve/ Orifice Size in. (mm)	Required Torque	
	ft-lb	N-m
0.25 (6.4)	20	27.1
0.38 (9.7)	100	135
0.47 (11.9)	200	271

Options

O-Ring Materials

Optional O-ring materials are available for all IPT series subsea service ball valves shown below. To order, add the optional O-ring material designator to the valve ordering number.

Examples:

Optional HNBR O-ring: SBV-NT-9MF9MF-H

Optional perfluorocarbon FFKM O-ring: SBV-NT-9MF9MF-C

O-Ring Material	Temperature Rating °F (°C)	Designator
HNBR	0 to 250 (-17 to 121)	-H
Perfluorocarbon FFKM	20 to 185 (-6 to 85)	-C

Dimensions

Dimensions, in inches (millimeters), are for reference only and are subject to change.

Samples of typical ordering numbers and dimensions are shown in the table below. See the Ordering Information on page 1130 to build ordering numbers for other subsea service ball valve configurations.

End Connections		Orifice in. (mm)	Ordering Number	Dimensions, in. (mm)		
Inlet/Outlet	Size			A	B	K
10 000 psig (689 bar)						
Cone and thread	9/16 in.	0.38 (9.7)	SBV-NT-9MF9MF	6.21 (158)	3.11 (79.0)	0.68 (17.3)
	1 in.	0.47 (11.9)	SBV-JT-16MF16MF	7.73 (196)	3.87 (98.3)	0.74 (18.8)
15 000 psig (1034 bar)						
Cone and thread	3/8 in.	0.25 (6.4)	SBV-MT-6MF6MF	4.84 (116)	2.42 (60.4)	0.48 (12.2)

For additional dimensions of valve configurations, contact your authorized Swagelok representative.

Valve Size: M (0.25 in.) Orifice

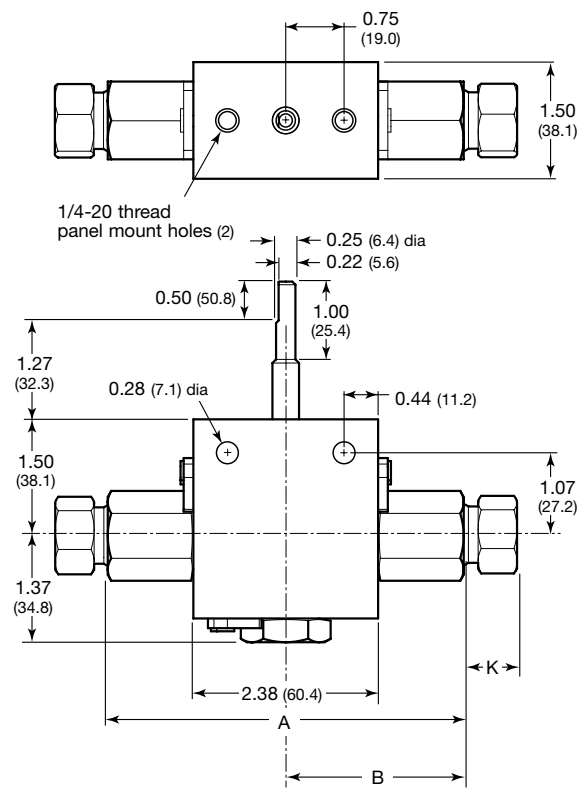

Shown with female medium-pressure cone and thread end connections

Valve Size: N (0.38 in.) Orifice

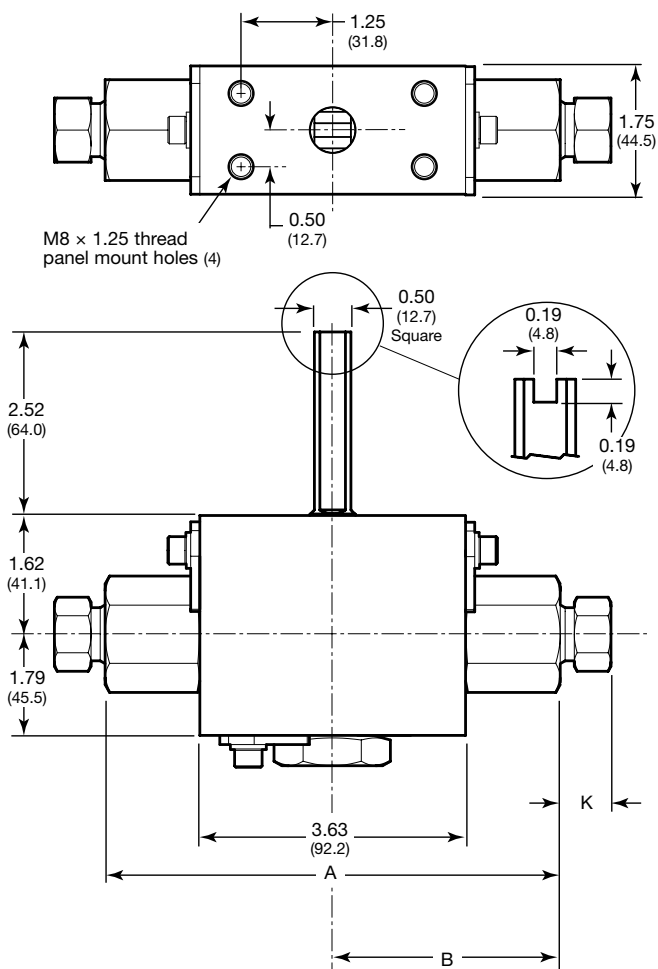

Shown with female medium-pressure cone and thread end connections

MEDIUM- AND HIGH-PRESSURE

Dimensions

Dimensions, in inches (millimeters), are for reference only and are subject to change.

Valve Size: J (0.47 in.) Orifice

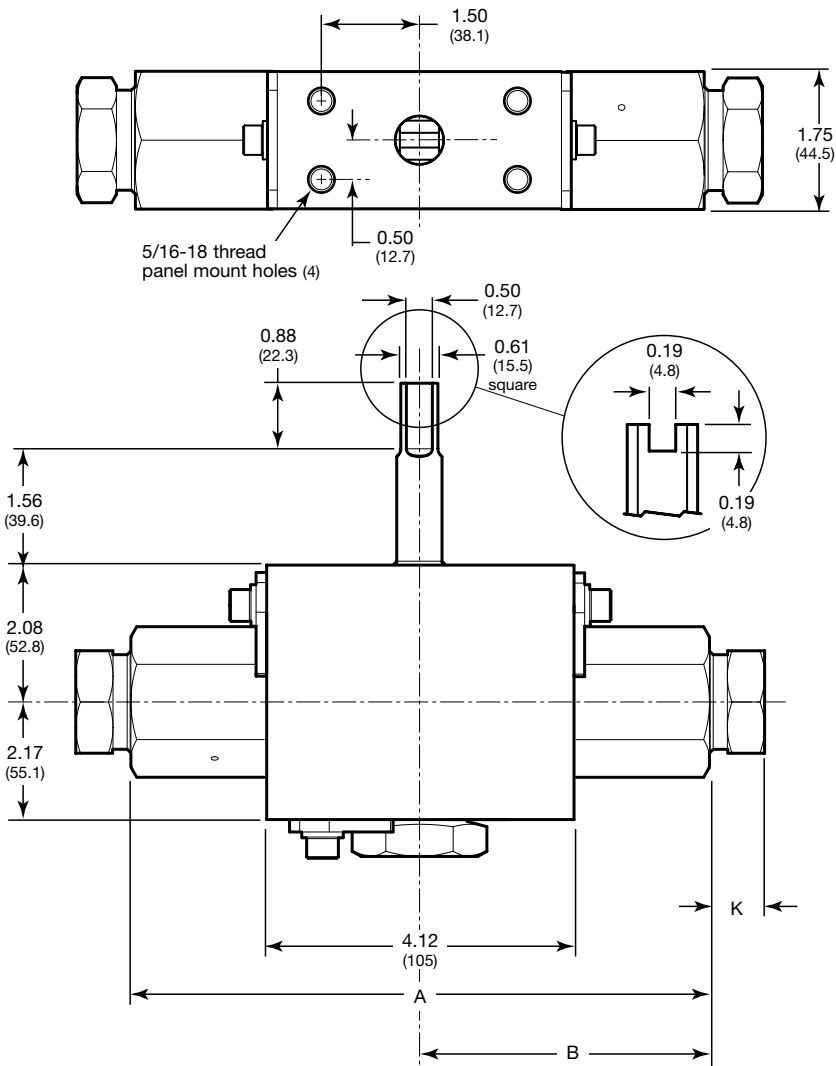

Shown with female medium-pressure cone and thread end connections

Ordering Information

Build a valve ordering number by combining the designators in the sequence shown below.

1
2
3
4
5
6
SBV - N T - 12NF 12NF - C

1 Valve Type
SBV = subsea service ball valve

2 Orifice Size
M = 0.25 in.
N = 0.38 in.
J = 0.47 in.

3 Flow Path
T = 2-way

4 End Connection Size
M Orifice Size (0.25 in.)
 4 = 1/4 in.
 6 = 3/8 in.
N Orifice Size (0.38 in.)
 8 = 1/2 in. (FNPT and FK only)
 9 = 9/16 in. (C&T and FK only)
J Orifice Size (0.47 in.)
 12 = 3/4 in.
 16 = 1 in. (FNPT and C&T only)

5 End Connection Type
 FK = Swagelok medium-pressure tube fitting
 NF = Female NPT
 MF = Female medium-pressure cone and thread

6 Seal Material
 None = Fluorocarbon FKM, standard
 H = HNBR
 C = Perfluorocarbon FFKM

Needle Valves—IPT Series

For Pressures up to 60 000 psig (4134 bar)



- 316 stainless steel construction
- Working pressures up to 60 000 psig (4134 bar)
- Temperatures up to 250°F (121°C) with PTFE packing; up to 650°F (343°C) with Grafoil® packing
- End connection sizes: 1/4, 3/8, 1/2, 9/16, 3/4, and 1 in.
- End connection styles:
 - Medium- and high-pressure cone and thread (C&T)
 - Medium-pressure NPT thread
 - Swagelok medium-pressure tube fitting (FK)
- Manual and pneumatically actuated valves

Features

- Vee or regulating stem tip.
- Packing below stem threads
- Integral through holes for bracket mounting
- Panel mounting option available.
- Available for sour gas applications. Materials are selected in accordance with NACE MR0175/ISO15156.

Pressure-Temperature Ratings

Ratings are based on manual valves with optional Grafoil packing. Ratings are limited to: 250°F (121°C) max with reinforced PTFE stem packing.

Temperature °F (°C)	Valve End Connection				
	Female NPT		Cone and Thread (C&T)		
	1/4, 3/8, and 1/2 in.	3/4 and 1 in.	Medium Pressure (1/4 to 1 in.)	High Pressure (1/4 to 9/16 in.)	
	Working Pressure, psig (bar) ^①				
-40 to 250 (-40 to 121)	15 000 (1034)	10 000 (689)	20 000 (1378)	30 000 (2067)	60 000 (4134)
250 to 300 (121 to 148)	14 400 (992)	9 600 (661)	19 200 (1322)	28 800 (1984)	57 600 (3968)
300 to 650 (148 to 343)	13 950 (961)	9 300 (640)	18 600 (1281)	27 900 (1922)	55 800 (3844)

① Working pressure determined based on ASME B31.3 Process Piping, Chapter IX High Pressure Piping.

Important Information About Needle Valves

- ⚠ **A packing adjustment may be required periodically to increase service life and to prevent leakage.**
- ⚠ **Valves that have not been cycled for a period of time may have a higher initial actuation torque.**
- ⚠ **To ensure proper valve performance, and prevent leakage, apply only as much torque as is required to achieve positive shutoff.**

NVT Design

- Standard design for manually actuated valves with 1/4, 3/8, 1/2, and 9/16 in. end connections
- Two-piece stem assembly.
- Nonrotating upper-to-lower stem connection located above packing to protect from system media.
- Full open in 4 to 5 turns.
- Bonnet machined from C63000 for reduced operation torque.
- Integral bonnet locking mechanism prevents accidental disassembly and allows for simple panel mounting.
- Stainless steel handle.
- 2-way, bi-directional valves.

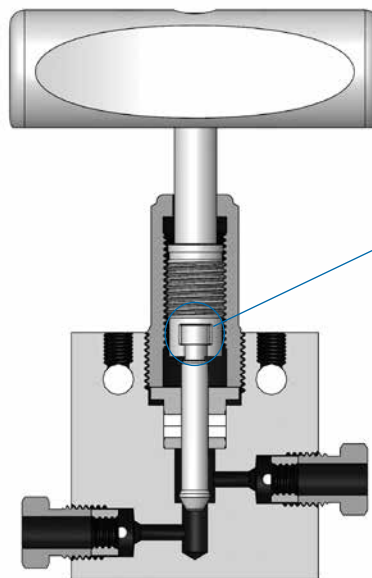

NVT Design Valve

Shown with
vee stem tip

NV Design

- Standard design for manually actuated valves with 3/4 and 1 in. end connections and all pneumatically actuated valves.
- Multipiece stem assembly.
- Nonrotating upper-to-lower stem connection located above packing to protect from system media.
- Full open in 8 to 9 turns.
- Stem bearing sleeve machined from S17400 stainless steel for reduced operation torque.
- Bonnet locking mechanism prevents accidental disassembly and allows for simple panel mounting.
- Anodized aluminum handle.

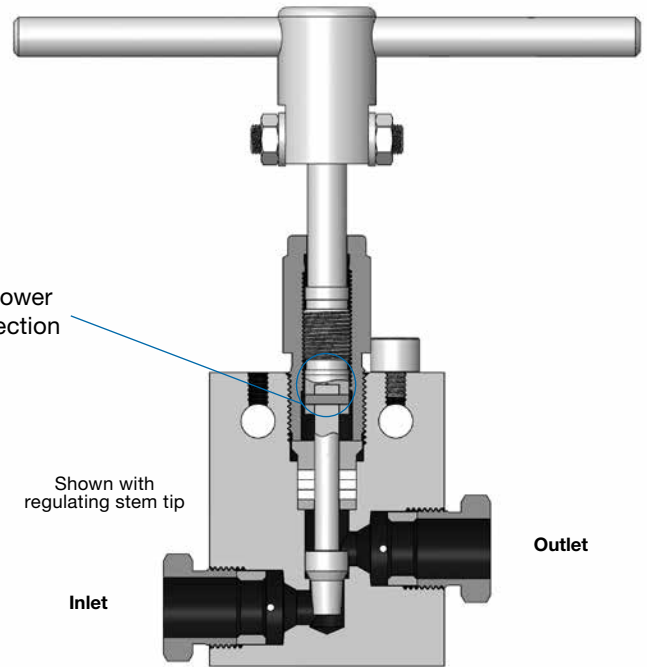

NV Design Valve

Shown with
regulating stem tip

Inlet

Outlet

Testing

Every NV and NVT needle valve is factory tested with water up to its maximum pressure rating to a requirement of no detectable leakage at the seat and packing.

Cleaning and Packaging

All NV and NVT needle valves are cleaned and packaged in accordance with Swagelok *Standard Cleaning and Packaging (SC-10)* (MS-06-62), page 1174.

Body Styles

- Available with cone and thread and NPT end connections.

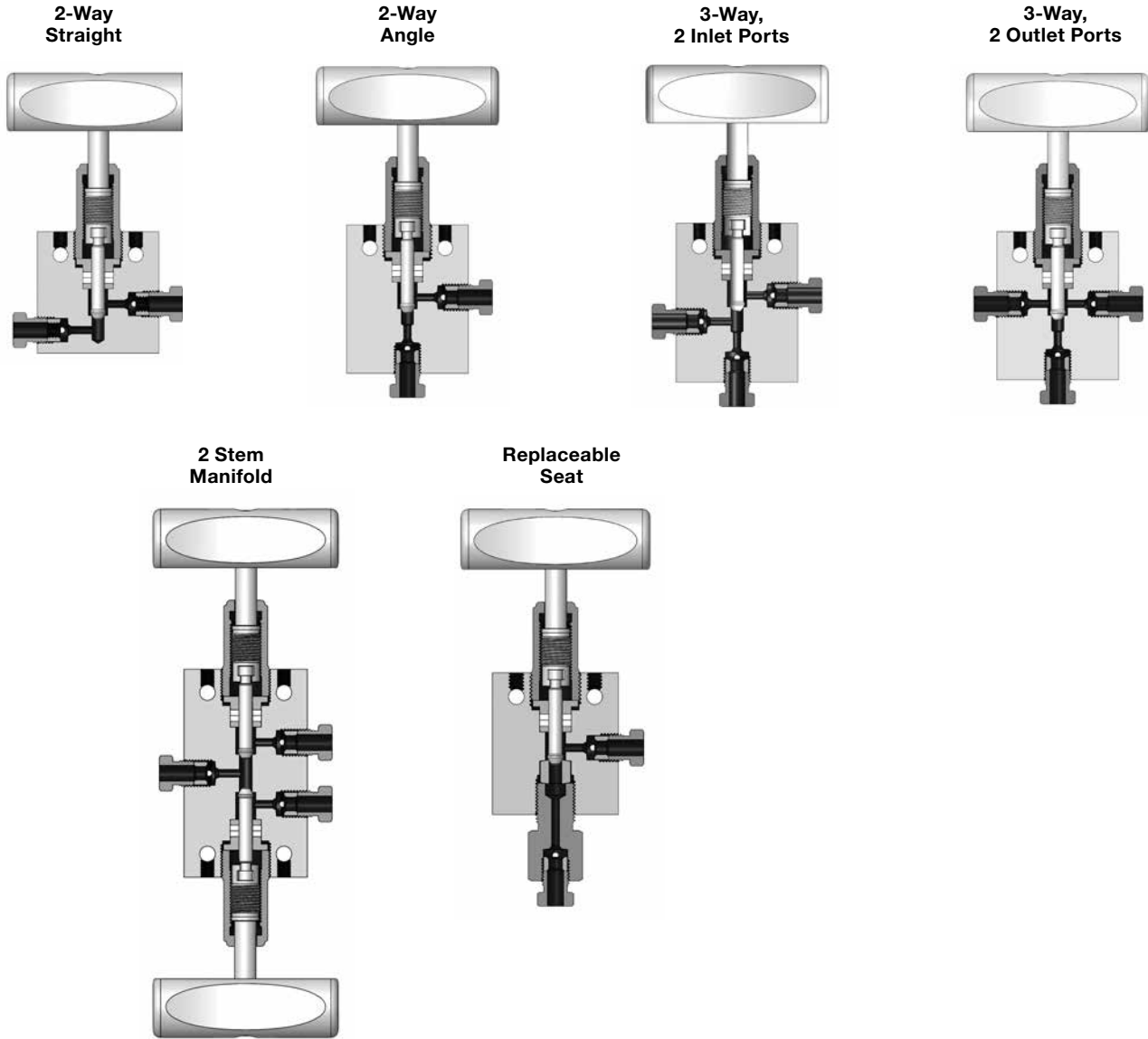

- Available with NPT end connections *only*

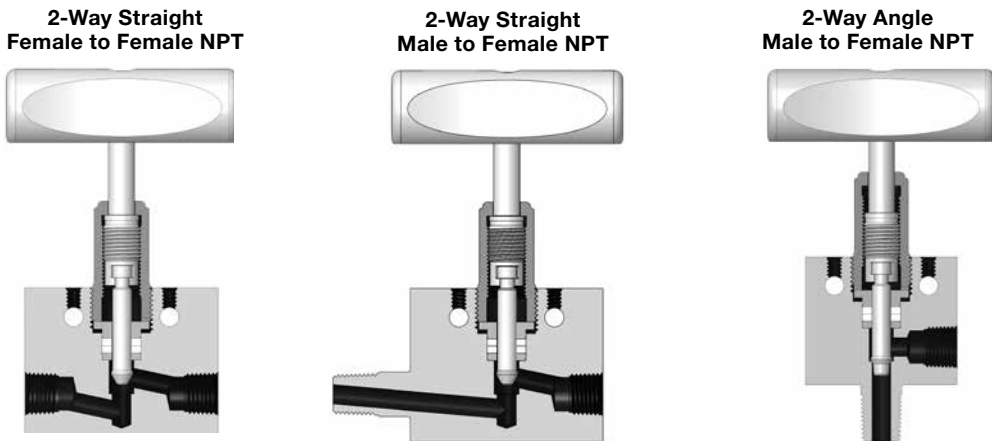

Materials of Construction

NVT Design

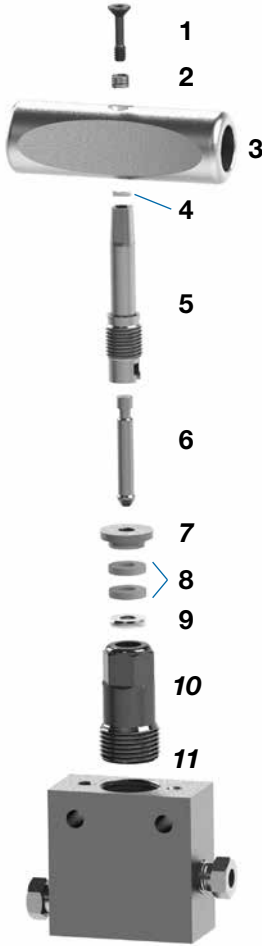

Component	Material Grade/ ASTM Specification
1 Socket head cap screw	316 SS
2 Spring	316 SS/A313
3 Handle	316 SS/A276 or A479
4 Retaining ring	
5 Upper stem	<i>S17400/A564, Type 630</i>
6 Lower stem	
7 Top packing washer	316 SS/A276 or A479
8 Packing ring	<i>Reinforced PTFE</i>
9 Bottom packing washer	316 SS/A276 or A479
10 Bonnet	C63000/B150
11 Body	316 SS/A276 or A479
Wetted lubricants	<i>Silicone based and fluorinated, PTFE based</i>
Nonwetted lubricants	Silicone based and fluorinated, PTFE based

Wetted components listed in *italics*.

NV Design

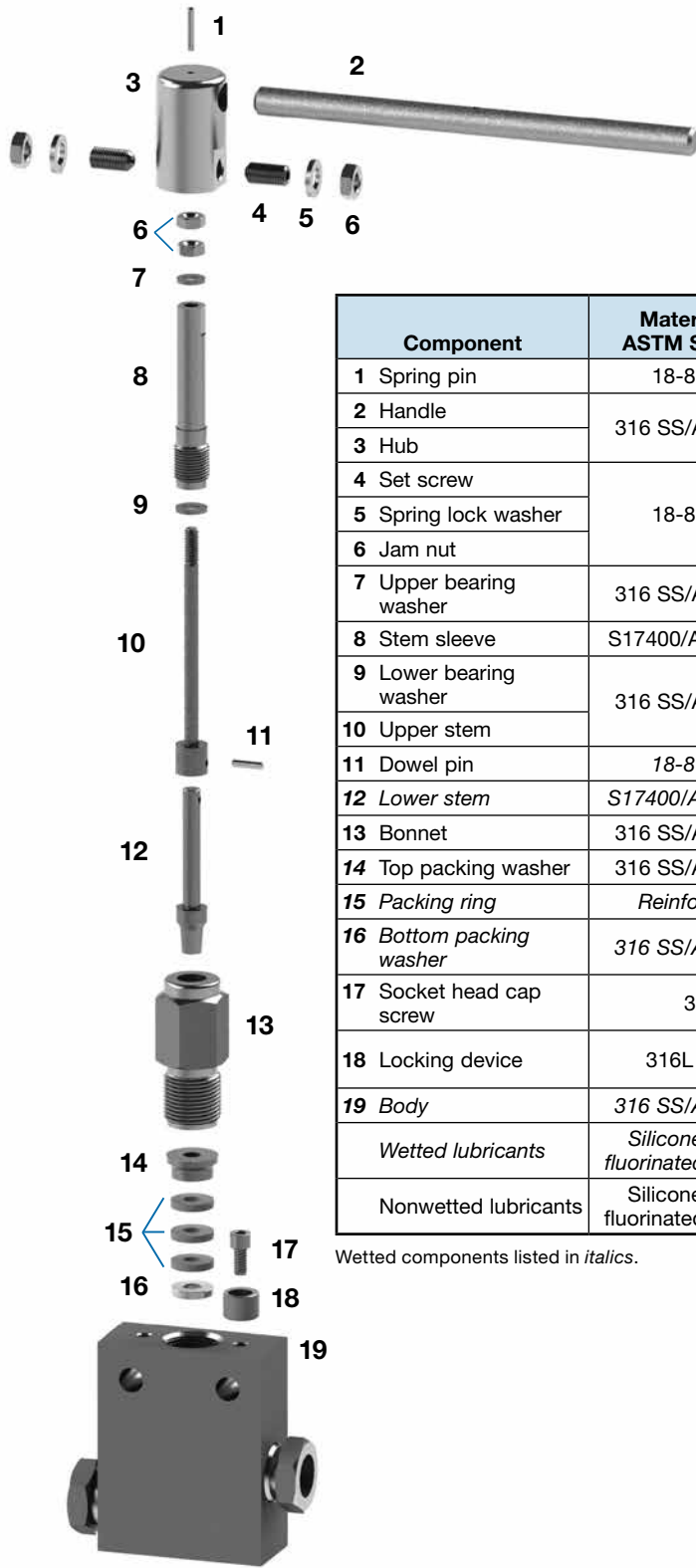

Component	Material Grade/ ASTM Specification
1 Spring pin	18-8 SS/A193
2 Handle	316 SS/A276 or A479
3 Hub	
4 Set screw	18-8 SS/A193
5 Spring lock washer	
6 Jam nut	316 SS/A276 or A479
7 Upper bearing washer	
8 Stem sleeve	<i>S17400/A564, Type 630</i>
9 Lower bearing washer	316 SS/A276 or A479
10 Upper stem	
11 Dowel pin	18-8 SS/A193
12 Lower stem	<i>S17400/A564, Type 630</i>
13 Bonnet	316 SS/A276 or A479
14 Top packing washer	316 SS/A276 or A479
15 Packing ring	<i>Reinforced PTFE</i>
16 Bottom packing washer	316 SS/A276 or A479
17 Socket head cap screw	316 SS
18 Locking device	316L SS/A-276
19 Body	316 SS/A276 or A479
Wetted lubricants	<i>Silicone based and fluorinated, PTFE based</i>
Nonwetted lubricants	Silicone based and fluorinated, PTFE based

Wetted components listed in *italics*.

Shown with cone and thread end connections

Flow Coefficient at Turns Open

NPT End Connections, 2-Way Straight Pattern

15 000 psig (1034 bar) Pressure Rating

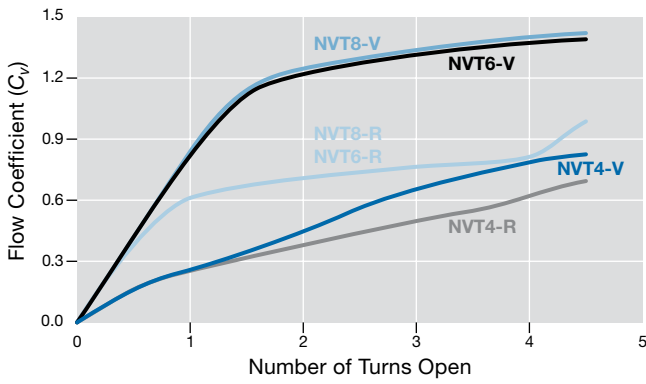

10 000 psig (689 bar) Pressure Rating

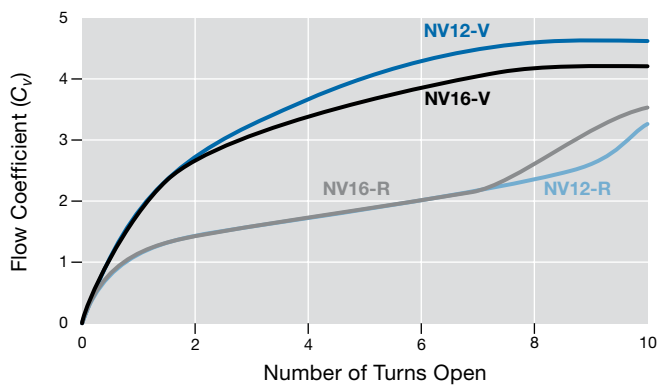

NPT End Connections, 2-Way Angle Pattern

15 000 psig (1034 bar) Pressure Rating

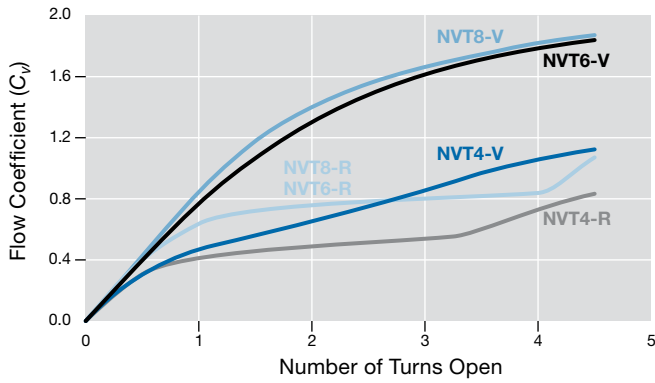

10 000 psig (689 bar) Pressure Rating

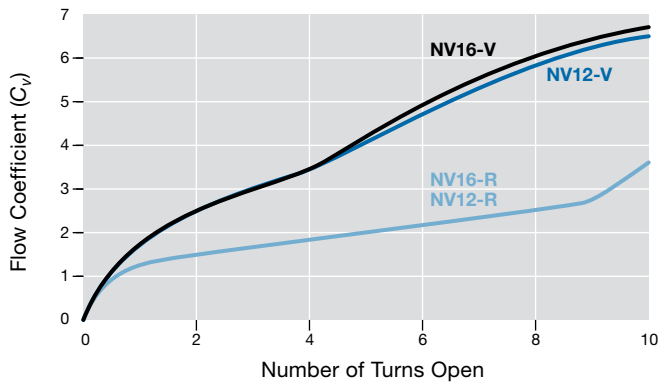

V = vee stem tip; R = regulating stem tip

Flow Coefficient at Turns Open

Medium Pressure C&T End Connections, 2-Way Straight Pattern

20 000 psig (1378 bar) Pressure Rating

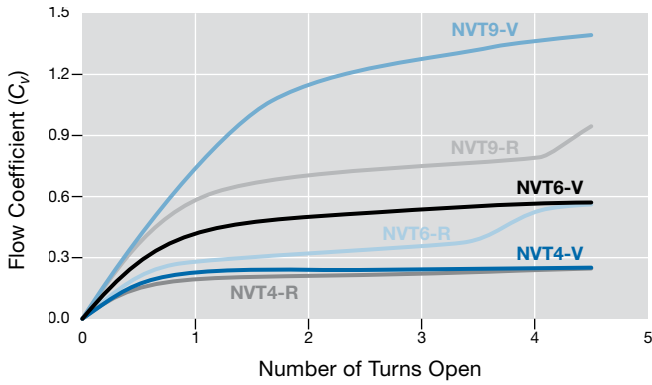

20 000 psig (1378 bar) Pressure Rating

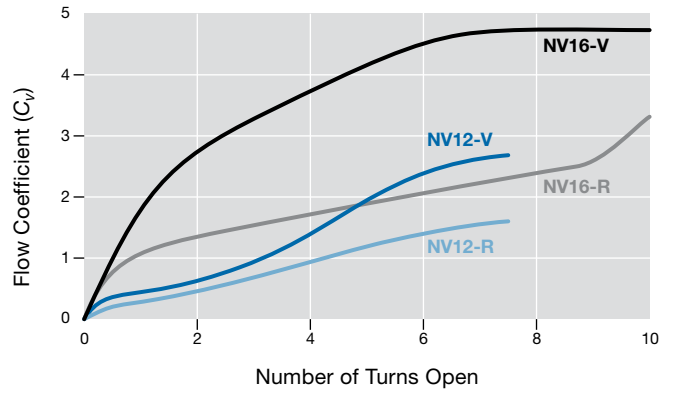

Medium Pressure C&T End Connections, 2-Way Angle Pattern

20 000 psig (1378 bar) Pressure Rating

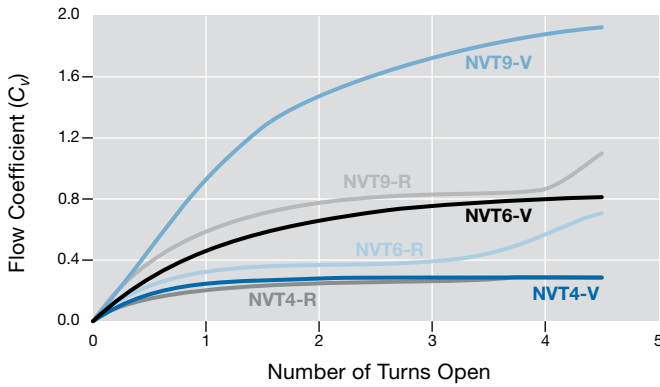

20 000 psig (1378 bar) Pressure Rating

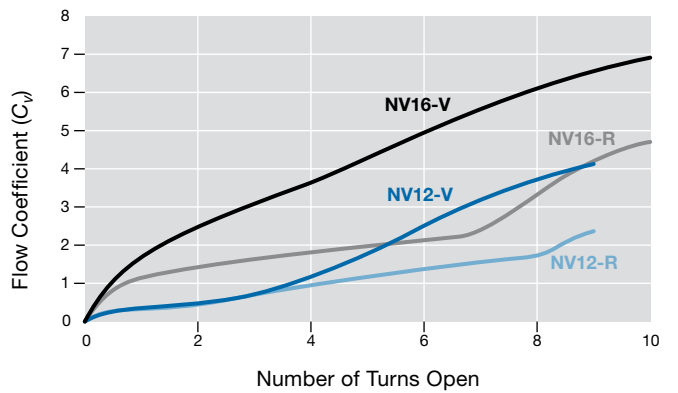

V = vee stem tip; R = regulating stem tip

Flow Coefficient at Turns Open

High Pressure C&T End Connections, 2-Way Straight Pattern

30 000 psig (2067 bar) Pressure Rating

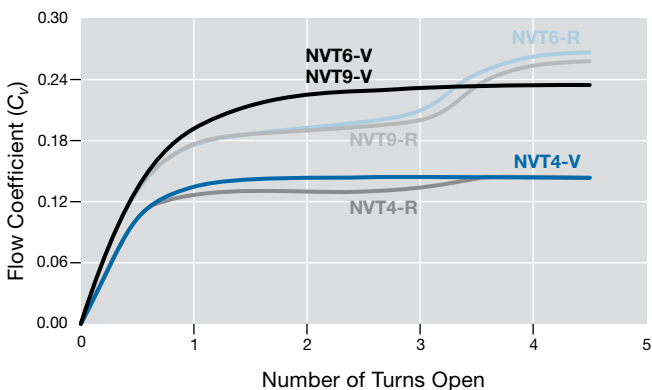

60 000 psig (4134 bar) Pressure Rating

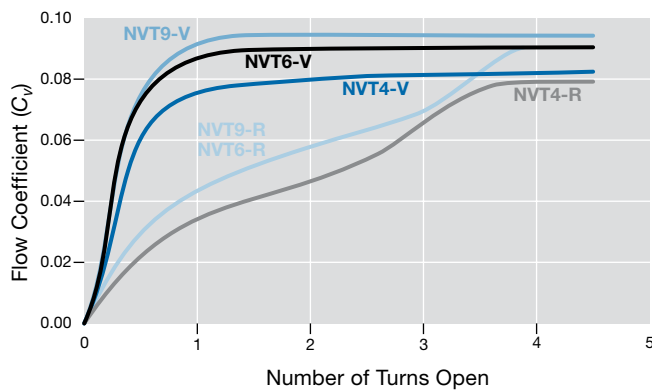

High Pressure C&T End Connections, 2-Way Angle Pattern

30 000 psig (2067 bar) Pressure Rating

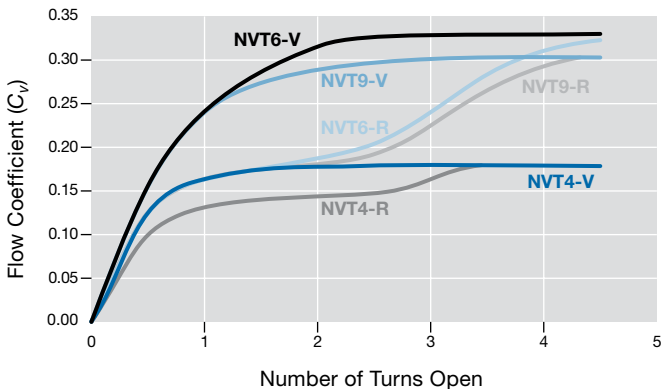

60 000 psig (4134 bar) Pressure Rating

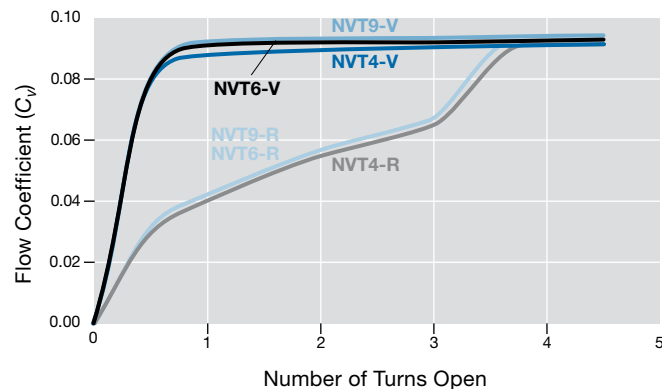

V = vee stem tip; R = regulating stem tip

Ordering Information and Dimensions

Dimensions, in inches (millimeters), are for reference only and are subject to change.

Select an ordering number.

Ordering numbers specify a vee stem tip.
To order a regulating stem tip, replace **V** in the ordering number with **R**.

Example: NVT4M1RA20

Options and Accessories

- For panel mounting, NACE-compliant valves, high temperature stem packing, and handle locking bracket see page 1145.

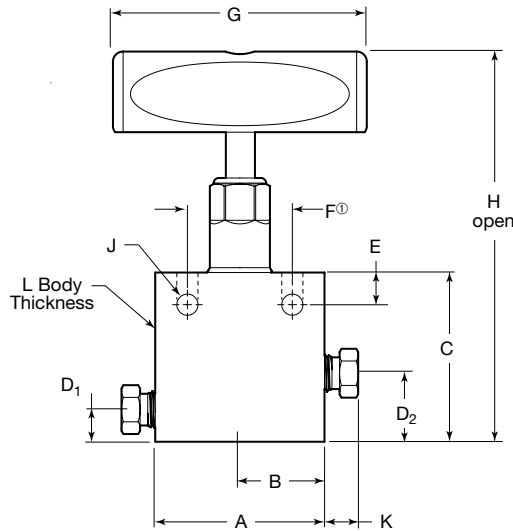

- ① Panel mounting holes
- NVT: #10 -24 UNC
- NV: Not available
- Bonnet clearance hole 0.82 in. (20.9 mm) dia
- Bonnet clearance hole on centerline
- Bolt clearance hole 7/32 in. (5.6 mm) dia

NVT style shown

2-Way Straight

End Connections		Ordering Number	Orifice in. (mm)	Dimensions, in. (mm)											
Inlet/Outlet	Size			A	B	C	D ₁	D ₂	E	F	G	H	J	K	L
10 000 psig (689 bar)															
Female NPT	3/4 in.	NV12N1VD10	0.56 (14.2)	4.12 (105)	2.06 (52.3)	4.75 (121)	1.00 (25.4)	1.94 (49.3)	1.12 (28.4)	2.50 (63.5)	10.0 (254)	10.1 (257)	0.56 (14.2)	—	1.75 (44.4)
	1 in.	NV16N1VD10	0.56 (14.2)	4.12 (105)	2.06 (52.3)	4.75 (121)	1.00 (25.4)	1.94 (49.3)	1.12 (28.4)	2.50 (63.5)	10.0 (254)	10.1 (257)	0.56 (14.2)	—	1.75 (44.4)
15 000 psig (1034 bar)															
Female NPT	1/4 in.	NVT4N1VG15	0.25 (6.4)	2.00 (50.8)	1.00 (25.4)	2.00 (50.8)	0.38 (9.7)	0.81 (20.6)	0.38 (9.7)	1.24 (31.5)	3.00 (76.2)	4.84 (123)	0.25 (6.4)	—	1.00 (25.4)
	3/8 in.	NVT6N1VB15	0.312 (7.9)	2.50 (63.5)	1.25 (31.8)	2.88 (73.2)	0.50 (12.7)	1.13 (28.7)	0.50 (12.7)	1.38 (35.1)	4.00 (102)	5.46 (139)	0.34 (8.6)	—	1.25 (31.8)
	1/2 in.	NVT8N1VB15	0.312 (7.9)	2.50 (63.5)	1.25 (31.8)	3.00 (76.2)	0.62 (15.7)	1.25 (31.8)	0.50 (12.7)	1.38 (35.1)	4.00 (102)	5.58 (142)	0.34 (8.6)	—	1.25 (31.8)
20 000 psig (1378 bar)															
Cone and thread	1/4 in.	NVT4M1VA20	0.125 (3.2)	2.00 (50.8)	1.00 (25.4)	2.00 (50.8)	0.38 (9.7)	0.81 (20.6)	0.38 (9.7)	1.24 (31.5)	3.00 (76.2)	4.84 (123)	0.25 (6.4)	0.38 (9.7)	1.00 (25.4)
	3/8 in.	NVT6M1VA20	0.20 (5.1)	2.00 (50.8)	1.00 (25.4)	2.00 (50.8)	0.38 (9.7)	0.81 (20.6)	0.38 (9.7)	1.24 (31.5)	3.00 (76.2)	4.84 (123)	0.25 (6.4)	0.48 (12.2)	1.00 (25.4)
	9/16 in.	NVT9M1VB20	0.312 (7.9)	2.50 (63.5)	1.25 (31.8)	2.88 (73.2)	0.50 (12.7)	1.13 (28.7)	0.50 (12.7)	1.38 (35.1)	4.00 (102)	5.46 (139)	0.34 (8.6)	0.68 (17.3)	1.25 (31.8)
	3/4 in.	NV12M1VC20	0.44 (11.2)	3.00 (76.2)	1.50 (38.1)	3.75 (95.3)	0.75 (19.1)	1.50 (38.1)	0.62 (15.7)	1.76 (44.7)	8.00 (203)	8.84 (225)	0.44 (11.2)	0.59 (15.0)	1.38 (35.1)
	1 in.	NV16M1VD20	0.56 (14.2)	4.12 (105)	2.06 (52.3)	4.75 (121)	1.00 (25.4)	1.94 (49.3)	1.12 (28.4)	2.50 (63.5)	10.0 (254)	10.1 (257)	0.56 (14.2)	0.74 (18.8)	1.75 (44.4)
30 000 psig (2067 bar)															
Cone and thread	1/4 in.	NVT4H1VY30	0.093 (2.4)	2.00 (50.8)	1.00 (25.4)	2.00 (50.8)	0.50 (12.7)	0.88 (22.4)	0.38 (9.7)	1.38 (35.1)	3.00 (76.2)	4.74 (120)	0.28 (7.1)	0.59 (15.0)	1.00 (25.4)
	3/8 in.	NVT6H1VY30	0.125 (3.2)	2.00 (50.8)	1.00 (25.4)	2.00 (50.8)	0.50 (12.7)	0.88 (22.4)	0.38 (9.7)	1.38 (35.1)	3.00 (76.2)	4.74 (120)	0.28 (7.1)	0.72 (18.3)	1.25 (31.8)
	9/16 in.	NVT9H1VY30	0.125 (3.2)	2.62 (66.5)	1.31 (33.3)	2.44 (62.0)	0.88 (22.4)	1.32 (33.5)	0.38 (9.7)	1.38 (35.1)	3.00 (76.2)	5.18 (132)	0.28 (7.1)	1.00 (25.4)	1.50 (38.1)
60 000 psig (4134 bar)															
Cone and thread	1/4 in.	NVT4H1VM60	0.062 (1.6)	2.00 (50.8)	1.00 (25.4)	2.12 (53.8)	0.43 (10.8)	0.82 (20.8)	0.38 (9.7)	1.38 (35.1)	3.00 (76.2)	4.89 (124)	0.28 (7.1)	0.59 (15.0)	1.00 (25.4)
	3/8 in.	NVT6H1VM60	0.062 (1.6)	2.00 (50.8)	1.00 (25.4)	2.25 (57.2)	0.43 (10.8)	0.82 (20.8)	0.38 (9.7)	1.38 (35.1)	3.00 (76.2)	5.02 (128)	0.28 (7.1)	0.72 (18.3)	1.25 (31.8)
	9/16 in.	NVT9H1VM60	0.062 (1.6)	2.62 (66.5)	1.31 (33.3)	2.50 (63.5)	0.75 (19.1)	1.19 (30.2)	0.38 (9.7)	1.38 (35.1)	3.00 (76.2)	5.27 (134)	0.28 (7.1)	1.00 (25.4)	1.50 (38.1)

For valves with Swagelok medium-pressure tube fitting connections, contact your authorized Swagelok representative.

Dimensions

Dimensions, in inches (millimeters), are for reference only and are subject to change.

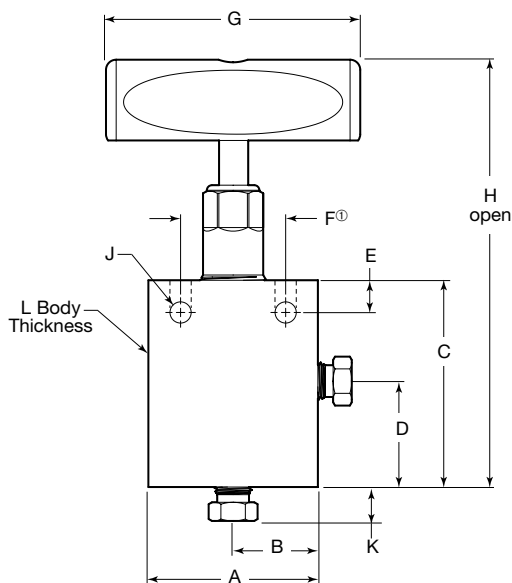

- ① Panel mounting holes
- NVT: #10 -24 UNC
- NV: Not available
- Bonnet clearance hole 0.82 in. (20.9 mm) dia
- Bonnet clearance hole on centerline
- Bolt clearance hole 7/32 in. (5.6 mm) dia

NVT style shown

2-Way Angle

End Connections		Ordering Number	Orifice in. (mm)	Dimensions, in. (mm)										
Inlet/Outlet	Size			A	B	C	D	E	F	G	H	J	K	L
10 000 psig (689 bar)														
Female NPT	3/4 in.	NV12N2VD10	0.56 (14.2)	4.12 (105)	2.06 (52.3)	5.50 (140)	2.69 (68.3)	1.12 (28.4)	2.50 (63.5)	10.0 (254)	11.0 (279)	0.56 (14.2)	—	1.75 (44.4)
	1 in.	NV16N2VD10	0.56 (14.2)	4.12 (105)	2.06 (52.3)	5.50 (140)	2.69 (68.3)	1.12 (28.4)	2.50 (63.5)	10.0 (254)	11.0 (279)	0.56 (14.2)	—	1.75 (44.4)
15 000 psig (1034 bar)														
Female NPT	1/4 in.	NVT4N2VG15	0.25 (6.4)	2.00 (50.8)	1.00 (25.4)	2.44 (62.0)	1.25 (31.8)	0.38 (9.7)	1.24 (31.5)	3.00 (76.2)	5.28 (134)	0.25 (6.4)	—	1.00 (25.4)
	3/8 in.	NVT6N2VB15	0.312 (7.9)	2.50 (63.5)	1.25 (31.8)	3.38 (85.9)	1.63 (41.4)	0.50 (12.7)	1.38 (35.1)	4.00 (102)	5.96 (151)	0.34 (8.6)	—	1.25 (31.8)
	1/2 in.	NVT8N2VB15	0.312 (7.9)	2.50 (63.5)	1.25 (31.8)	3.38 (85.9)	1.63 (41.4)	0.50 (12.7)	1.38 (35.1)	4.00 (102)	5.96 (151)	0.34 (8.6)	—	1.25 (31.8)
20 000 psig (1378 bar)														
Cone and thread	1/4 in.	NVT4M2VA20	0.125 (3.2)	2.00 (50.8)	1.00 (25.4)	2.44 (62.0)	1.25 (31.8)	0.38 (9.7)	1.24 (31.5)	3.00 (76.2)	5.28 (123)	0.25 (6.4)	0.38 (9.7)	1.00 (25.4)
	3/8 in.	NVT6M2VA20	0.20 (5.1)	2.00 (50.8)	1.00 (25.4)	2.44 (62.0)	1.25 (31.8)	0.38 (9.7)	1.24 (31.5)	3.00 (76.2)	5.28 (123)	0.25 (6.4)	0.48 (12.2)	1.00 (25.4)
	9/16 in.	NVT9M2VB20	0.312 (7.9)	2.50 (63.5)	1.25 (31.8)	3.38 (85.9)	1.63 (41.4)	0.50 (12.7)	1.38 (35.1)	4.00 (102)	5.96 (151)	0.34 (8.6)	0.68 (17.3)	1.38 (35.1)
	3/4 in.	NV12M2VC20	0.44 (11.2)	3.00 (76.2)	1.50 (38.1)	4.50 (114)	2.25 (57.2)	0.62 (15.7)	1.76 (44.7)	8.00 (203)	9.58 (243)	0.44 (11.2)	0.59 (15.0)	1.75 (44.4)
	1 in.	NV16M2VD20	0.56 (14.2)	4.12 (105)	2.06 (52.3)	5.50 (140)	2.69 (68.3)	1.12 (28.4)	2.50 (63.5)	10.0 (254)	10.8 (275)	0.56 (14.2)	0.74 (18.8)	1.75 (44.4)
30 000 psig (2067 bar)														
Cone and thread	1/4 in.	NVT4H2VY30	0.093 (2.4)	2.00 (50.8)	1.00 (25.4)	2.00 (50.8)	0.88 (22.4)	0.38 (9.7)	1.38 (35.1)	3.00 (76.2)	4.74 (120)	0.28 (7.1)	0.59 (15.0)	1.00 (25.4)
	3/8 in.	NVT6H2VY30	0.125 (3.2)	2.00 (50.8)	1.00 (25.4)	2.12 (53.8)	1.00 (25.4)	0.38 (9.7)	1.38 (35.1)	3.00 (76.2)	4.86 (123)	0.28 (7.1)	0.72 (18.3)	1.50 (38.1)
	9/16 in.	NVT9H2VY30	0.125 (3.2)	2.62 (66.5)	1.31 (33.3)	2.44 (62.0)	1.32 (33.5)	0.38 (9.7)	1.38 (35.1)	3.00 (76.2)	5.18 (132)	0.28 (7.1)	1.00 (25.4)	1.50 (38.1)
60 000 psig (4134 bar)														
Cone and thread	1/4 in.	NVT4H2VM60	0.062 (1.6)	2.00 (50.8)	1.00 (25.4)	2.38 (60.5)	1.07 (27.2)	0.38 (9.7)	1.38 (35.1)	3.00 (76.2)	5.15 (131)	0.28 (7.1)	0.59 (15.0)	1.00 (25.4)
	3/8 in.	NVT6H2VM60	0.062 (1.6)	2.00 (50.8)	1.00 (25.4)	2.62 (66.5)	1.31 (33.3)	0.38 (9.7)	1.38 (35.1)	3.00 (76.2)	5.39 (137)	0.28 (7.1)	0.72 (18.3)	1.50 (38.1)
	9/16 in.	NVT9H2VM60	0.062 (1.6)	2.62 (66.5)	1.31 (33.3)	2.81 (71.4)	1.50 (38.1)	0.38 (9.7)	1.38 (35.1)	3.00 (76.2)	5.58 (142)	0.28 (7.1)	1.00 (25.4)	1.50 (38.1)

For valves with Swagelok medium-pressure tube fitting connections, contact your authorized Swagelok representative.

Dimensions

Dimensions, in inches (millimeters), are for reference only and are subject to change.

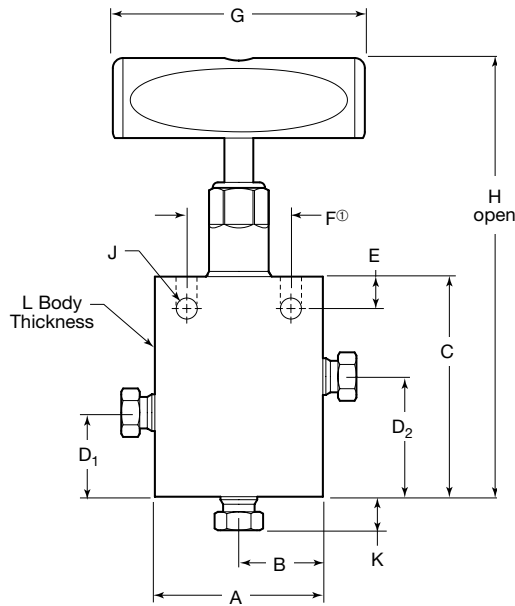

- ① Panel mounting holes (not shown)
- NVT: #10 -24 UNC
- NV: Not available
- Bonnet clearance hole 0.82 in. (20.9 mm) dia
- Bonnet clearance hole on centerline
- Bolt clearance hole 7/32 in. (5.6 mm) dia

NVT style shown

3-Way, 2 Inlet Ports

End Connections		Ordering Number	Orifice in. (mm)	Dimensions, in. (mm)											
Inlet/Outlet	Size			A	B	C	D ₁	D ₂	E	F	G	H	J	K	L
15 000 psig (1034 bar)															
Female NPT	1/4 in.	NVT4N3VG15	0.25 (6.4)	2.00 (50.8)	1.00 (25.4)	2.62 (66.5)	1.00 (25.4)	1.43 (36.3)	0.38 (9.7)	1.24 (31.5)	3.00 (76.2)	5.46 (139)	0.25 (6.4)	—	1.00 (25.4)
	3/8 in.	NVT6N3VB15	0.312 (7.9)	2.50 (63.5)	1.25 (31.8)	3.62 (91.9)	1.24 (31.5)	1.87 (47.5)	0.50 (12.7)	1.38 (35.1)	4.00 (102)	6.20 (157)	0.34 (8.6)	—	—
	1/2 in.	NVT8N3VB15	0.312 (7.9)	2.50 (63.5)	1.25 (31.8)	3.62 (91.9)	1.24 (31.5)	1.87 (47.5)	0.50 (12.7)	1.38 (35.1)	4.00 (102)	6.20 (157)	0.34 (8.6)	—	1.25 (31.8)
20 000 psig (1378 bar)															
Cone and thread	1/4 in.	NVT4M3VA20	0.125 (3.2)	2.00 (50.8)	1.00 (25.4)	2.62 (66.5)	1.00 (25.4)	1.43 (36.3)	0.38 (9.7)	1.24 (31.5)	3.00 (76.2)	5.46 (139)	0.25 (6.4)	0.38 (9.7)	1.00 (25.4)
	3/8 in.	NVT6M3VA20	0.20 (5.1)	2.00 (50.8)	1.00 (25.4)	2.62 (66.5)	1.00 (25.4)	1.43 (36.3)	0.38 (9.7)	1.24 (31.5)	3.00 (76.2)	5.46 (139)	0.25 (6.4)	0.48 (12.2)	—
	9/16 in.	NVT9M3VB20	0.312 (7.9)	2.50 (63.5)	1.25 (31.8)	3.63 (92.2)	1.25 (31.8)	1.88 (47.8)	0.50 (12.7)	1.38 (35.1)	4.00 (102)	6.21 (158)	0.34 (8.6)	0.68 (17.3)	—
30 000 psig (2067 bar)															
Cone and thread	1/4 in.	NVT4H3VY30	0.093 (2.4)	2.00 (50.8)	1.00 (25.4)	2.12 (53.8)	0.62 (15.7)	1.00 (25.4)	0.38 (9.7)	1.38 (35.1)	3.00 (76.2)	4.86 (123)	0.28 (7.1)	0.59 (15.0)	1.00 (25.4)
	3/8 in.	NVT6H3VY30	0.125 (3.2)	2.00 (50.8)	1.00 (25.4)	2.50 (63.5)	1.00 (25.4)	1.38 (35.1)	0.38 (9.7)	1.38 (35.1)	3.00 (76.2)	5.24 (133)	0.28 (7.1)	0.72 (18.3)	—
	9/16 in.	NVT9H3VY30	0.125 (3.2)	2.62 (66.5)	1.31 (33.3)	2.88 (73.2)	1.32 (33.5)	1.76 (44.7)	0.38 (9.7)	1.38 (35.1)	3.00 (76.2)	5.62 (143)	0.28 (7.1)	1.00 (25.4)	1.50 (38.1)
60 000 psig (4134 bar)															
Cone and thread	1/4 in.	NVT4H3VM60	0.062 (1.6)	2.00 (50.8)	1.00 (25.4)	2.38 (60.5)	0.69 (17.5)	1.07 (27.2)	0.38 (9.7)	1.38 (35.1)	3.00 (76.2)	5.15 (131)	0.28 (7.1)	0.59 (15.0)	1.00 (25.4)
	3/8 in.	NVT6H3VM60	0.062 (1.6)	2.00 (50.8)	1.00 (25.4)	2.75 (69.8)	1.06 (26.9)	1.44 (36.6)	0.38 (9.7)	1.38 (35.1)	3.00 (76.2)	5.52 (140)	0.28 (7.1)	0.72 (18.3)	—
	9/16 in.	NVT9H3VM60	0.062 (1.6)	2.62 (66.5)	1.31 (33.3)	3.03 (77.0)	1.28 (32.5)	1.72 (43.7)	0.38 (9.7)	1.38 (35.1)	3.00 (76.2)	5.82 (148)	0.28 (7.1)	1.00 (25.4)	1.50 (38.1)

For valves with Swagelok medium-pressure tube fitting connections, contact your authorized Swagelok representative.

Dimensions

Dimensions, in inches (millimeters), are for reference only and are subject to change.

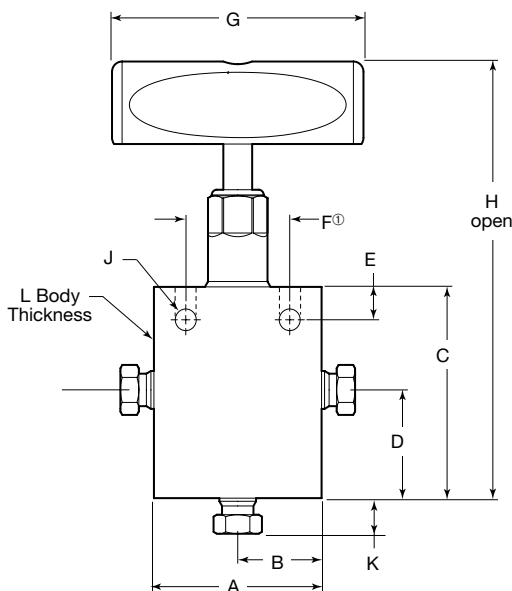

- ① Panel mounting holes (not shown)
 - NVT: #10 -24 UNC
 - NV: Not available
 - Bonnet clearance hole 0.82 in. (20.9 mm) dia
 - Bonnet clearance hole on centerline
 - Bolt clearance hole 7/32 in. (5.6 mm) dia
- NVT style shown**

3-Way, 2 Outlet Ports

End Connections		Ordering Number	Orifice in. (mm)	Dimensions, in. (mm)										
Inlet/Outlet	Size			A	B	C	D	E	F	G	H	J	K	L
15 000 psig (1034 bar)														
Female NPT	1/4 in.	NVT4N4VG15	0.25 (6.4)	2.00 (50.8)	1.00 (25.4)	2.44 (62.0)	1.25 (31.8)	0.38 (9.7)	1.24 (31.5)	3.00 (76.2)	5.28 (134)	0.25 (6.4)	—	1.00 (25.4)
	3/8 in.	NVT6N4VB15	0.312 (7.9)	2.50 (63.5)	1.25 (31.8)	3.38 (85.9)	1.63 (41.4)	0.50 (12.7)	1.38 (35.1)	4.00 (102)	5.96 (151)	0.34 (8.6)	—	1.25 (31.8)
	1/2 in.	NVT8N4VB15	0.312 (7.9)	2.50 (63.5)	1.25 (31.8)	3.38 (85.9)	1.63 (41.4)	0.50 (12.7)	1.38 (35.1)	4.00 (102)	5.96 (151)	0.34 (8.6)	—	1.25 (31.8)
20 000 psig (1378 bar)														
Cone and thread	1/4 in.	NVT4M4VA20	0.125 (3.2)	2.00 (50.8)	1.00 (25.4)	2.44 (62.0)	1.25 (31.8)	0.38 (9.7)	1.24 (31.5)	3.00 (76.2)	5.28 (134)	0.25 (6.4)	0.38 (9.7)	1.00 (25.4)
	3/8 in.	NVT6M4VA20	0.20 (5.1)	2.00 (50.8)	1.00 (25.4)	2.44 (62.0)	1.25 (31.8)	0.38 (9.7)	1.24 (31.5)	3.00 (76.2)	5.28 (134)	0.25 (6.4)	0.48 (12.2)	1.00 (25.4)
	9/16 in.	NVT9M4VB20	0.312 (7.9)	2.50 (63.5)	1.25 (31.8)	3.38 (85.9)	1.63 (41.4)	0.50 (12.7)	1.38 (35.1)	4.00 (102)	5.96 (151)	0.34 (8.6)	0.68 (17.3)	1.00 (25.4)
30 000 psig (2067 bar)														
Cone and thread	1/4 in.	NVT4H4VY30	0.093 (2.4)	2.00 (50.8)	1.00 (25.4)	2.00 (50.8)	0.88 (22.4)	0.38 (9.7)	1.38 (35.1)	3.00 (76.2)	4.74 (120)	0.28 (7.1)	0.59 (15.0)	1.00 (25.4)
	3/8 in.	NVT6H4VY30	0.125 (3.2)	2.00 (50.8)	1.00 (25.4)	2.12 (53.8)	1.00 (25.4)	0.38 (9.7)	1.38 (35.1)	3.00 (76.2)	4.86 (123)	0.28 (7.1)	0.72 (18.3)	1.00 (25.4)
	9/16 in.	NVT9H4VY30	0.125 (3.2)	2.62 (66.5)	1.31 (33.3)	2.44 (62.0)	1.32 (33.5)	0.38 (9.7)	1.38 (35.1)	3.00 (76.2)	5.18 (132)	0.28 (7.1)	1.00 (25.4)	1.00 (25.4)
60 000 psig (4134 bar)														
Cone and thread	1/4 in.	NVT4H4VM60	0.062 (1.6)	2.00 (50.8)	1.00 (25.4)	2.38 (60.5)	1.07 (27.2)	0.38 (9.7)	1.38 (35.1)	3.00 (76.2)	5.15 (131)	0.28 (7.1)	0.59 (15.0)	1.00 (25.4)
	3/8 in.	NVT6H4VM60	0.062 (1.6)	2.00 (50.8)	1.00 (25.4)	2.62 (66.5)	1.31 (33.3)	0.38 (9.7)	1.38 (35.1)	3.00 (76.2)	5.39 (137)	0.28 (7.1)	0.72 (18.3)	1.00 (25.4)
	9/16 in.	NVT9H4VM60	0.062 (1.6)	2.62 (66.5)	1.31 (33.3)	2.81 (71.4)	1.31 (33.3)	0.38 (9.7)	1.50 (38.1)	3.00 (76.2)	5.58 (142)	0.28 (7.1)	1.00 (25.4)	1.50 (38.1)

For valves with Swagelok medium-pressure tube fitting connections, contact your authorized Swagelok representative.

Dimensions

Dimensions, in inches (millimeters), are for reference only and are subject to change.

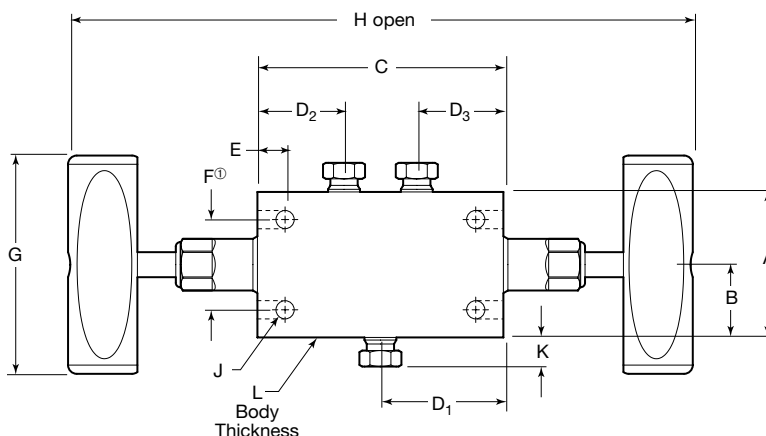

- ① Panel mounting holes (not shown)
- NVT: #10 -24 UNC
- NV: Not available
- Bonnet clearance hole 0.82 in. (20.9 mm) dia
- Bonnet clearance hole on centerline
- Bolt clearance hole 7/32 in. (5.6 mm) dia

NVT style shown

2 Stem Manifold

End Connections		Ordering Number	Orifice in. (mm)	Dimensions, in. (mm)												
Inlet/Outlet	Size			A	B	C	D ₁	D ₂	D ₃	E	F	G	H	J	K	L
15 000 psig (1034 bar)																
Female NPT	1/4 in.	NVT4N5VG15	0.25 (6.4)	2.00 (50.8)	1.00 (25.4)	3.38 (85.9)	1.69 (42.9)	1.19 (30.2)	1.19 (30.2)	0.38 (9.7)	1.24 (31.5)	3.00 (76.2)	9.06 (230)	0.25 (6.4)	—	1.00 (25.4)
	3/8 in.	NVT6N5VB15	0.312 (7.9)	2.50 (63.5)	1.25 (31.8)	5.12 (130)	2.56 (65.0)	1.75 (44.4)	1.75 (44.4)	0.50 (12.7)	1.38 (35.1)	4.00 (102)	10.3 (262)	0.34 (8.6)	—	—
	1/2 in.	NVT8N5VB15	0.312 (7.9)	2.50 (63.5)	1.25 (31.8)	5.12 (130)	2.56 (65.0)	1.75 (44.4)	1.75 (44.4)	0.50 (12.7)	1.38 (35.1)	4.00 (102)	10.3 (262)	0.34 (8.6)	—	1.25 (31.8)
20 000 psig (1378 bar)																
Cone and thread	1/4 in.	NVT4M5VA20	0.125 (3.2)	2.00 (50.8)	1.00 (25.4)	3.38 (85.9)	1.69 (42.9)	1.19 (30.2)	1.19 (30.2)	0.38 (9.7)	1.24 (31.5)	3.00 (76.2)	9.06 (230)	0.25 (6.4)	0.38 (9.7)	—
	3/8 in.	NVT6M5VA20	0.20 (5.1)	2.00 (50.8)	1.00 (25.4)	3.38 (85.9)	1.69 (42.9)	1.19 (30.2)	1.19 (30.2)	0.38 (9.7)	1.24 (31.5)	3.00 (76.2)	9.06 (230)	0.25 (6.4)	0.48 (12.2)	1.00 (25.4)
	9/16 in.	NVT9M5VB20	0.312 (7.9)	2.50 (63.5)	1.25 (31.8)	5.12 (130)	2.56 (65.0)	1.75 (44.4)	1.75 (44.4)	0.50 (12.7)	1.38 (35.1)	4.00 (102)	10.3 (262)	0.34 (8.6)	0.68 (17.3)	—
30 000 psig (2067 bar)																
Cone and thread	1/4 in.	NVT4H5VY30	0.093 (2.4)	2.00 (50.8)	1.00 (25.4)	3.06 (77.7)	1.53 (38.9)	1.12 (28.4)	1.12 (28.4)	0.38 (9.7)	1.38 (35.1)	3.00 (76.2)	8.54 (217)	0.28 (7.1)	0.59 (15.0)	—
	3/8 in.	NVT6H5VY30	0.125 (3.2)	2.00 (50.8)	1.00 (25.4)	3.25 (82.6)	1.62 (41.1)	1.12 (28.4)	1.12 (28.4)	0.38 (9.7)	1.38 (35.1)	3.00 (76.2)	8.73 (222)	0.28 (7.1)	0.72 (18.3)	1.00 (25.4)
	9/16 in.	NVT9H5VY30	0.125 (3.2)	2.62 (66.5)	1.31 (33.3)	3.75 (95.2)	1.88 (47.8)	1.12 (28.4)	1.12 (28.4)	0.38 (9.7)	1.38 (35.1)	3.00 (76.2)	9.23 (234)	0.28 (7.1)	1.00 (25.4)	—
60 000 psig (4134 bar)																
Cone and thread	1/4 in.	NVT4H5VM60	0.062 (1.6)	2.00 (50.8)	1.00 (25.4)	3.44 (87.4)	1.72 (43.7)	1.31 (33.3)	1.31 (33.3)	0.38 (9.7)	1.38 (35.1)	3.00 (76.2)	8.98 (228)	0.28 (7.1)	0.59 (15.0)	1.00 (25.4)
	3/8 in.	NVT6H5VM60	0.062 (1.6)	2.00 (50.8)	1.00 (25.4)	3.75 (95.2)	1.88 (47.8)	1.31 (33.3)	1.31 (33.3)	0.38 (9.7)	1.38 (35.1)	3.00 (76.2)	9.29 (236)	0.28 (7.1)	0.72 (18.3)	—
	9/16 in.	NVT9H5VM60	0.062 (1.6)	2.62 (66.5)	1.31 (33.3)	4.12 (105)	2.06 (52.3)	1.31 (33.3)	1.31 (33.3)	0.38 (9.7)	1.38 (35.1)	3.00 (76.2)	9.66 (245)	0.28 (7.1)	1.00 (25.4)	1.50 (38.1)

For valves with Swagelok medium-pressure tube fitting connections, contact your authorized Swagelok representative.

Dimensions

Dimensions, in inches (millimeters), are for reference only and are subject to change.

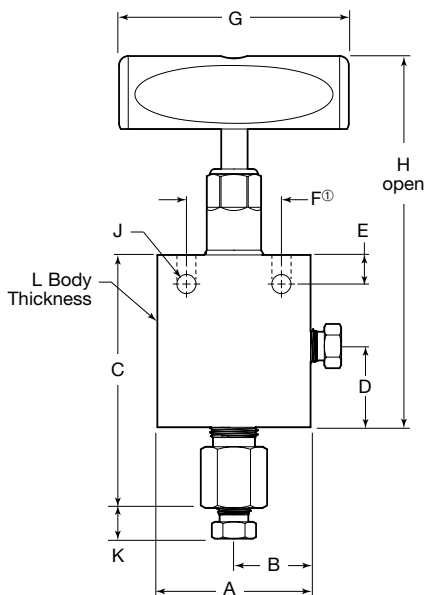

- ① Panel mounting holes (not shown)
- NVT: #10 -24 UNC
- NV: Not available
- Bonnet clearance hole 0.82 in. (20.9 mm) dia
- Bonnet clearance hole on centerline
- Bolt clearance hole 7/32 in. (5.6 mm) dia

NVT style shown

Replaceable Seat

End Connections		Ordering Number	Orifice in. (mm)	Dimensions, in. (mm)											
Inlet/Outlet	Size in.			A	B	C	D	E	F	G	H	J	K	L	
15 000 psig (1034 bar)															
Female NPT	1/4	NVT4N6VG15	0.25 (6.4)	2.00 (50.8)	1.00 (25.4)	3.13 (79.5)	1.06 (26.9)	0.38 (9.7)	1.24 (31.5)	3.00 (76.2)	5.09 (129)	0.25 (6.4)	—	1.00 (25.4)	
	3/8	NVT6N6VB15	0.312 (7.9)	2.50 (63.5)	1.25 (31.8)	4.47 (114)	1.50 (38.1)	0.50 (12.7)	1.38 (35.1)	4.00 (102)	5.83 (148)	0.34 (8.6)	—		
	1/2	NVT8N6VB15	0.312 (7.9)	2.50 (63.5)	1.25 (31.8)	4.47 (114)	1.50 (38.1)	0.50 (12.7)	1.38 (35.1)	4.00 (102)	5.83 (148)	0.34 (8.6)	—	1.25 (31.8)	
20 000 psig (1378 bar)															
Cone and thread	1/4	NVT4M6VA20	0.125 (3.2)	2.00 (50.8)	1.00 (25.4)	3.30 (83.8)	1.06 (26.9)	0.38 (9.7)	1.24 (31.5)	3.00 (76.2)	5.09 (129)	0.25 (6.4)	0.38 (9.7)	1.00 (25.4)	
	3/8	NVT6M6VA20	0.20 (5.1)	2.00 (50.8)	1.00 (25.4)	3.30 (83.8)	1.06 (26.9)	0.38 (9.7)	1.24 (31.5)	3.00 (76.2)	5.09 (129)	0.25 (6.4)	0.48 (12.2)		
	9/16	NVT9M6VB20	0.312 (7.9)	2.50 (63.5)	1.25 (31.8)	4.63 (118)	1.50 (38.1)	0.50 (12.7)	1.38 (35.1)	4.00 (102)	5.83 (148)	0.34 (8.6)	0.68 (17.3)		
	3/4	NV12M6VC20	0.44 (11.2)	3.00 (76.2)	1.50 (38.1)	5.40 (137)	1.50 (38.1)	0.62 (15.7)	1.76 (44.7)	8.00 (203)	8.83 (224)	0.44 (11.2)	0.59 (15.0)		1.38 (35.1)
	1	NV16M6VD20	0.56 (14.2)	3.62 (91.9)	1.81 (46.0)	7.16 (182)	2.25 (57.2)	1.12 (28.4)	2.50 (63.5)	10.0 (254)	10.5 (267)	0.56 (14.2)	0.74 (18.8)		1.75 (44.4)
30 000 psig (2067 bar)															
Cone and thread	1/4	NVT4H6VY30	0.093 (2.4)	2.00 (50.8)	1.00 (25.4)	3.46 (87.9)	1.26 (32.0)	0.38 (9.7)	1.38 (35.1)	3.00 (76.2)	5.12 (130)	0.28 (7.1)	0.59 (15.0)	1.00 (25.4)	
	3/8	NVT6H6VY30	0.125 (3.2)	2.00 (50.8)	1.00 (25.4)	3.37 (85.6)	1.26 (32.0)	0.38 (9.7)	1.38 (35.1)	3.00 (76.2)	5.12 (130)	0.28 (7.1)	0.72 (18.3)		
	9/16	NVT9H6VY30	0.125 (3.2)	2.62 (66.5)	1.31 (33.3)	3.64 (92.5)	1.25 (31.8)	0.38 (9.7)	1.38 (35.1)	3.00 (76.2)	5.18 (132)	0.28 (7.1)	1.00 (25.4)		1.50 (38.1)
60 000 psig (4134 bar)															
Cone and thread	1/4	NVT4H6VM60	0.062 (1.6)	2.00 (50.8)	1.00 (25.4)	3.62 (91.9)	1.31 (33.3)	0.38 (9.7)	1.38 (35.1)	3.00 (76.2)	5.39 (137)	0.28 (7.1)	0.59 (15.0)	1.00 (25.4)	
	3/8	NVT6H6VM60	0.062 (1.6)	2.00 (50.8)	1.00 (25.4)	3.82 (97.0)	1.31 (33.3)	0.38 (9.7)	1.38 (35.1)	3.00 (76.2)	5.39 (137)	0.28 (7.1)	0.72 (18.3)		
	9/16	NVT9H6VM60	0.062 (1.6)	2.62 (66.5)	1.31 (33.3)	4.01 (102)	1.31 (33.3)	0.38 (9.7)	1.38 (35.1)	3.00 (76.2)	5.39 (137)	0.28 (7.1)	1.00 (25.4)		1.50 (38.1)

For valves with Swagelok medium-pressure tube fitting connections, contact your authorized Swagelok representative.

MEDIUM- AND HIGH-PRESSURE

Dimensions

Dimensions, in inches (millimeters), are for reference only and are subject to change.

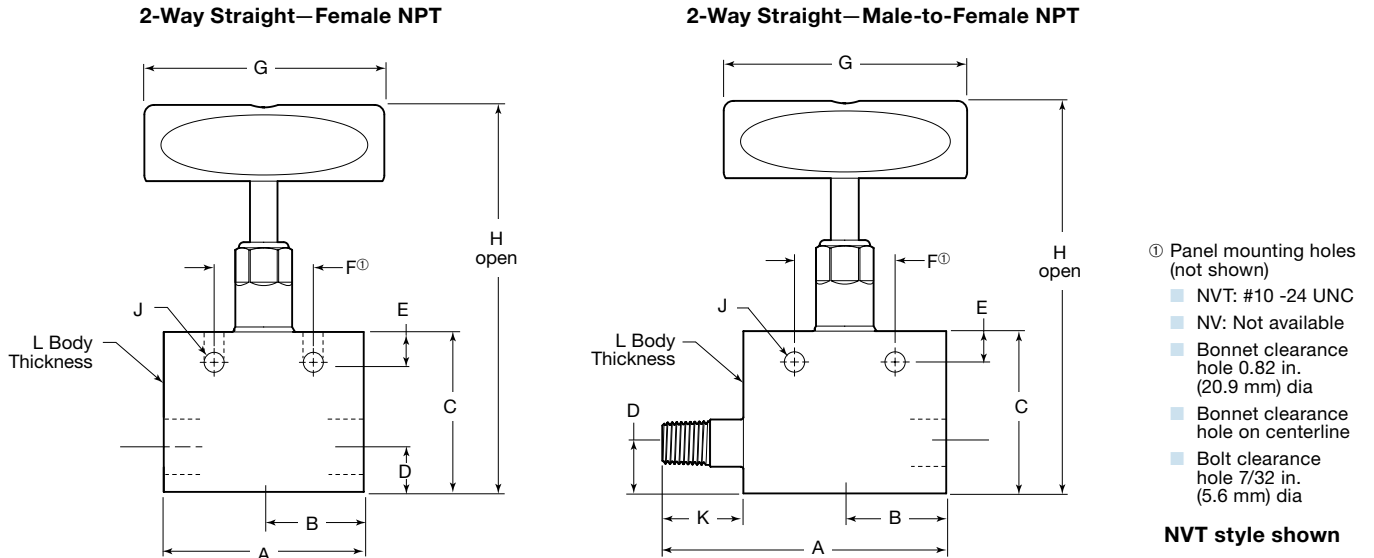

2-Way Straight—Female NPT

End Connections		Ordering Number	Orifice in. (mm)	Dimensions, in. (mm)									
Inlet/Outlet	Size			A	B	C	D	E	F	G	H	J	L
10 000 psig (689 bar)													
Female NPT	3/4 in.	NV12N1VF10	0.56 (14.2)	4.12 (105)	2.06 (52.3)	4.75 (121)	1.50 (38.1)	1.12 (28.4)	2.50 (63.5)	10.0 (254)	10.1 (257)	0.56 (14.2)	1.75 (44.4)
	1 in.	NV16N1VF10	0.56 (14.2)	4.12 (105)	2.06 (52.3)	4.75 (121)	1.50 (38.1)	1.12 (28.4)	2.50 (63.5)	10.0 (254)	10.1 (257)	0.56 (14.2)	1.75 (44.4)
15 000 psig (1034 bar)													
Female NPT	1/4 in.	NVT4N1VE15	0.25 (6.4)	2.50 (63.5)	1.25 (31.8)	2.00 (50.8)	0.62 (15.7)	0.38 (9.7)	1.24 (31.5)	3.00 (76.2)	4.84 (123)	0.25 (6.4)	1.00 (25.4)
	3/8 in.	NVT6N1VE15	0.25 (6.4)	2.50 (63.5)	1.25 (31.8)	2.00 (50.8)	0.62 (15.7)	0.38 (9.7)	1.24 (31.5)	3.00 (76.2)	4.84 (123)	0.25 (6.4)	
	1/2 in.	NVT8N1VE15	0.25 (6.4)	2.50 (63.5)	1.25 (31.8)	2.00 (50.8)	0.62 (15.7)	0.38 (9.7)	1.24 (31.5)	3.00 (76.2)	4.84 (123)	0.25 (6.4)	1.25 (31.8)

2-Way Straight—Male-to-Female NPT

End Connections		Ordering Number	Orifice in. (mm)	Dimensions, in. (mm)										
Inlet/Outlet	Size			A	B	C	D	E	F	G	H	J	K	L
15 000 psig (1034 bar)														
Male-female NPT	1/4 in.	NVT4N7VE15	0.25 (6.4)	3.50 (88.9)	1.25 (31.8)	2.00 (50.8)	0.62 (15.7)	0.38 (9.7)	1.24 (31.5)	3.00 (76.2)	4.84 (123)	0.25 (6.4)	1.00 (25.4)	1.00 (25.4)
	3/8 in.	NVT6N7VE15	0.25 (6.4)	3.50 (88.9)	1.25 (31.8)	2.00 (50.8)	0.62 (15.7)	0.38 (9.7)	1.24 (31.5)	3.00 (76.2)	4.84 (123)	0.25 (6.4)	1.00 (25.4)	1.00 (25.4)
	1/2 in.	NVT8N7VE15	0.25 (6.4)	3.50 (88.9)	1.25 (31.8)	2.00 (50.8)	0.62 (15.7)	0.38 (9.7)	1.24 (31.5)	3.00 (76.2)	4.84 (123)	0.25 (6.4)	1.00 (25.4)	1.25 (31.8)

For valves with Swagelok medium-pressure tube fitting connections, contact your authorized Swagelok representative.

Dimensions

Dimensions, in inches (millimeters), are for reference only and are subject to change.

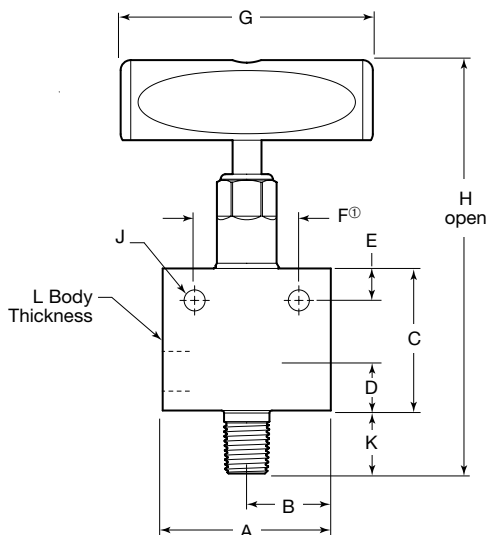

① Panel mounting holes (not shown)

- NVT: #10 -24 UNC
- NV: Not available
- Bonnet clearance hole 0.82 in. (20.9 mm) dia
- Bonnet clearance hole on centerline
- Bolt clearance hole 7/32 in. (5.6 mm) dia

NVT style shown

Angle—Male-to-Female NPT

End Connections		Ordering Number	Orifice in. (mm)	Dimensions, in. (mm)										
Inlet/Outlet	Size			A	B	C	D	E	F	G	H	J	K	L
10 000 psig (689 bar)														
Male-Female NPT	3/4 in.	NV12N8VF10	0.56 (14.2)	4.12 (105)	2.06 (52.3)	4.00 (102)	0.75 (19.0)	1.12 (28.4)	2.50 (63.5)	10.0 (254)	10.1 (257)	0.56 (14.2)	0.75 (19.0)	1.88 (47.8)
	1 in.	NV16N8VF10	0.56 (14.2)	4.12 (105)	2.06 (52.3)	4.19 (106)	0.94 (23.9)	1.12 (28.4)	2.50 (63.5)	10.0 (254)	10.1 (257)	0.56 (14.2)	0.94 (23.9)	1.88 (47.8)
15 000 psig (1034 bar)														
Male-Female NPT	1/4 in.	NVT4N8VE15	0.25 (6.4)	2.00 (50.8)	1.00 (25.4)	1.69 (42.9)	0.50 (12.7)	0.38 (9.7)	1.24 (31.5)	3.00 (76.2)	5.28 (134)	0.25 (6.4)	0.75 (19.0)	1.00 (25.4)
	3/8 in.	NVT6N8VE15	0.25 (6.4)	2.50 (63.5)	1.25 (31.8)	1.69 (42.9)	0.50 (12.7)	0.38 (9.7)	1.24 (31.5)	3.00 (76.2)	5.28 (134)	0.25 (6.4)	0.75 (19.0)	1.00 (25.4)
	1/2 in.	NVT8N8VE15	0.25 (6.4)	2.50 (63.5)	1.25 (31.8)	1.81 (46.0)	0.62 (15.7)	0.38 (9.7)	1.24 (31.5)	3.00 (76.2)	5.65 (144)	0.25 (6.4)	1.00 (25.4)	1.25 (31.8)

For valves with Swagelok medium-pressure tube fitting connections, contact your authorized Swagelok representative.

Options

Bonnet Locking Bracket

A bonnet locking bracket is available for NVT design valves to prevent accidental removal of the bonnet. To order an NVT valve with factory-assembled bonnet locking bracket, add **-BLD** to the valve ordering number.

Example: NVT4M1VA20-**BLD**

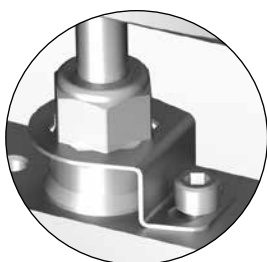

High-Temperature Stem Packing

Grafoil stem packing is available for temperatures up to 650°F (343°C). To order valves with factory-assembled Grafoil packing, add **-GR** to the valve ordering number.

Example: NVT4M1VA20-**GR**

Note: Grafoil is not available with Y stem series.

Hydrogen Compatible Stem Material

Nitronic® 50 stem material is available for hydrogen compatibility. To order valves with factory-assembled Nitronic 50 stem material, add **-N50** to the valve ordering number.

Example: NVT4M1VA20-**N50**

Note: Standard stem packing material is PTFE.

NACE-Compliant Valves for Sour Gas Service

NV and NVT valves are available for sour gas service. Materials are selected in accordance with NACE MR0175/ISO 15156. For more information on valves for sour gas service, contact your authorized Swagelok representative.

Panel Mounting

NVT valves can be panel mounted by two methods:

- Bolt panel mounting is standard on all NVT valves. Two UNC tapped holes in the valve body are shown by dimension F in the dimensional view above.
- Nut panel mounting is optional for NVT valves. To order an NVT valve with a threaded bonnet and nut, add **-PM** to the valve ordering number.
Example: NVT4M1VA20-**PM**

Pneumatic and Hydraulic Actuators

Pneumatic and hydraulic actuators are designed for remote actuation where manual actuation is difficult or impractical. Pneumatic actuators are available in normally open, normally closed, and double acting modes.

- Single-action actuators have built-in safety mechanisms which automatically close or open upon a loss in air pressure. They include the pneumatically actuated normally closed and normally open actuators.
 - Normally closed—Air is required to open (AO) the valve; any loss in air pressure automatically closes the valve.
 - Normally open—Air is required to close (AC) the valve; any loss in air pressure automatically opens the valve.
- Double-acting—Air is required to open and close (DA) actuators in a controlled motion, using air or hydraulic pressure.

Pressure-Temperature Ratings

- Pressure Rating: See **Actuator Selection Guide** on page 1148 to select a pneumatic or hydraulic actuator based on valve and actuator ratings.
- Temperature Rating: 200°F (93°C)

Materials of Construction

Component	Material Grade/ ASTM Specifications
Housing, cover, piston, mounting plate, bonnet	Alloy 6061/B21, B247, B361
Piston rod, actuator stem, insert	316 SS/A276 or A479
Springs (AC, AO)	Chrome silicone
Piston bearing	C63000/B150
Spring bearing (AC)	316L SS/A276
Lock nuts (AC)	316 SS/ASME B18.2.2
Cap screws	316 SS
O-rings	Fluorocarbon FKM or Buna N
Adjusting screw	18-8 SS
Filter disc (AC, AO)	316L SS/A276

Cleaning and Packaging

All pneumatic and hydraulically actuated needle valves are cleaned and packaged in accordance with Swagelok *Standard Cleaning and Packaging (SC-10)* (MS-06-62), page 1174.

Ordering Information

All pneumatic and hydraulic actuated needle valves feature the NV design components.

To order a valve with a factory-assembled pneumatic or hydraulic actuator, select a manual valve ordering number and modify as follows:

- Change **NVT** to **NV** in the ordering number.
- Add the desired actuator designator shown below to the valve ordering number.
- For valves with 1/4 in. female NPT connections, change the **G** stem designator in the ordering number to **A**.

Examples:

- Manual valve ordering number: NVT6N8VE10;
Pneumatic valve ordering number: **NV6N8VE10-AO50**
- Manual valve ordering number with 1/4 in. female NPT connections: NVT4N1VG15;
Pneumatic valve ordering number: **NV4N1VA15-AC19**

Actuator Designators		
Pneumatic Models		
Actuation Mode	Series 19 (5 in.)	Series 50 (8 in.)
Normally closed	-AO19	-AO50
Double acting	-DA19	-DA50
Normally open	-AC19	-AC50
Hydraulic Model		
Double action	-HD2	—

⚠ Caution: Actuated assemblies must be properly aligned and supported. Improper alignment or inadequate support of the actuated assembly may result in leakage or premature valve failure.

Dimensions

Dimensions, in inches (millimeters), are for reference only and are subject to change.

Pneumatic Normally Open

Shown: AC19 actuator

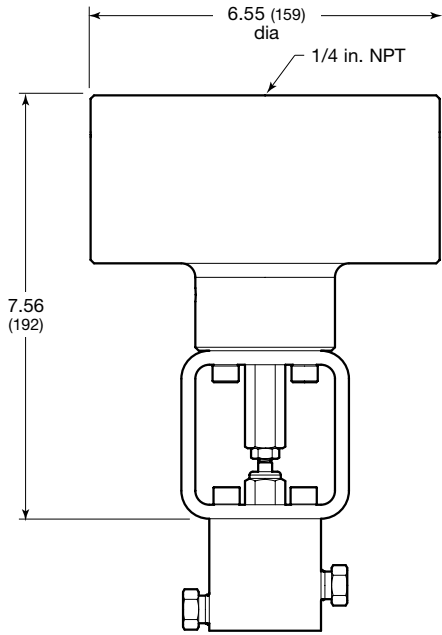

Pneumatic Normally Closed

Shown: AO19 actuator

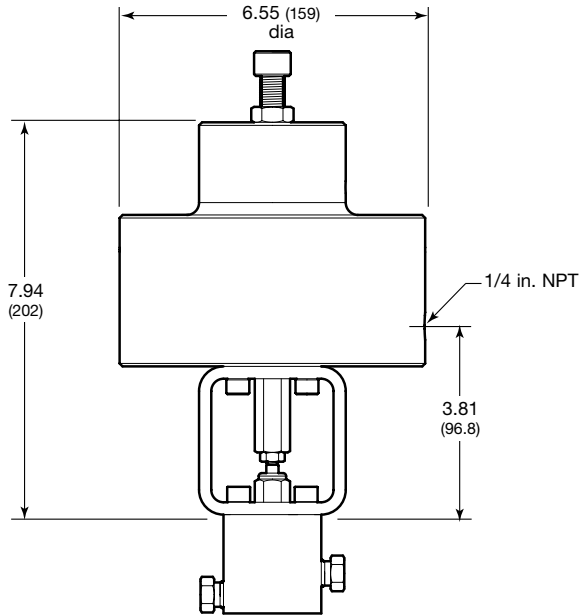

Pneumatic Double Acting

Shown: DA19 actuator

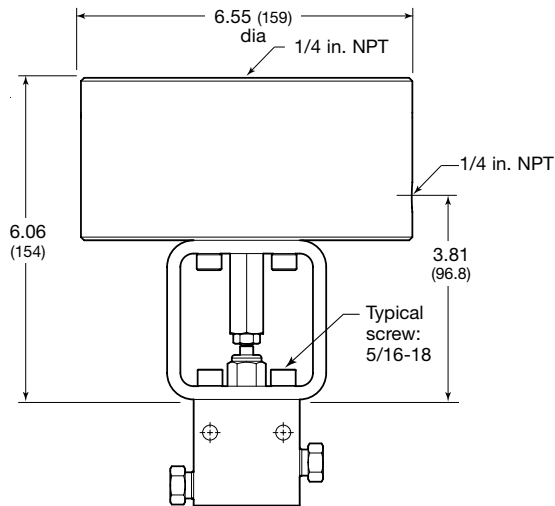

Hydraulic Double Acting

Shown: HD2 actuator

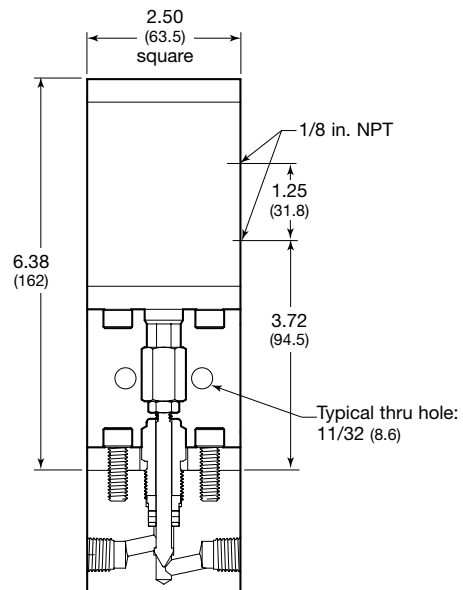

Actuator Selection Guide

See tables below for actuator models and pressure ratings based on maximum pressure rating of the NV or NVT series needle valve.

Pneumatic Normally Open Actuators

Maximum Pressure of Valve psig (bar)	Tube OD in.	Model AC19		Model AC50	
		System Pressure	Minimum Actuator Pressure	System Pressure	Minimum Actuator Pressure
		Pressure Rating, psig (bar)			
Up to 20 000 (1 378)	1/4 to 3/8	20 000 (1378)	74 (5.1)	—	—
	1/2 to 9/16	18 000 (1240)	100 (6.9)	20 000 (1378)	49 (3.4)
	3/4	—	—	20 000 (1378)	101 (7.0)
	1	—	—	12 000 (826)	100 (6.9)
30 000 (2 067)	1/4 to 9/16	30 000 (2067)	35 (2.5)	—	—
60 000 (4 134)	1/4 to 9/16	60 000 (4134)	23 (1.6)	—	—

Pneumatic Double Acting Actuators

Maximum Pressure of Valve psig (bar)	Tube OD in.	Model DA19		Model DA50	
		System Pressure	Minimum Actuator Pressure	System Pressure	Minimum Actuator Pressure
		Pressure Rating, psig (bar)			
Up to 20 000 (1378)	1/4 to 3/8	20 000 (1378)	63 (4.4)	—	—
	1/2 to 9/16	20 000 (1378)	98 (6.8)	—	—
	3/4	—	—	20 000 (1378)	90 (6.3)
	1	—	—	12 000 (826)	89 (6.2)
30 000 (2067)	1/4 to 9/16	30 000 (2067)	23 (1.6)	—	—
60 000 (4134)	1/4 to 9/16	60 000 (4134)	12 (0.83)	—	—

Pneumatic Normally Closed Actuators

Maximum Pressure of Valve psig (bar)	Tube OD in.	Model AO19		Model AO50	
		System Pressure	Minimum Actuator Pressure	System Pressure	Minimum Actuator Pressure
		Pressure Rating, psig (bar)			
Up to 20 000 (1378)	1/4 to 3/8	20 000 (1378)	82 (5.7)	—	—
	1/2 to 9/16	14 000 (964)	84 (5.8)	20 000 (1378)	58 (4.0)
	3/4	—	—	12 500 (861)	66 (4.6)
	1	—	—	7 500 (516)	66 (4.6)
30 000 (2067)	1/4 to 9/16	30 000 (2067)	78 (5.4)	—	—
60 000 (4134)	1/4 to 9/16	60 000 (4134)	88 (6.1)	—	—

Hydraulic Double Acting Actuators

Maximum Pressure of Valve psig (bar)	Tube OD in.	Model HD2	
		System Pressure	Minimum Actuator Pressure
		Pressure Rating, psig (bar)	
Up to 20 000 (1378)	1/4 to 3/8	20 000 (1378)	592 (40.8)
	1/2 to 9/16	20 000 (1378)	925 (63.8)
	3/4	—	—
	1	—	—
30 000 (2067)	1/4 to 9/16	30 000 (2067)	222 (15.3)
60 000 (4134)	1/4 to 9/16	60 000 (4134)	111 (7.7)

Maintenance Kits

For maintenance kit information, contact your authorized Swagelok representative.

High-Pressure Needle Valves—Sno-Trik

For Pressures up to 45 000 psig (3100 bar)



- Working pressures up to 45 000 psig (3100 bar)
- Temperatures up to 450°F (232°C) with glass-filled PTFE packing; up to 850°F (454°C) with Grafoil packing.
- 316 stainless steel construction
- End connection styles and sizes:
 - Straight thread high-pressure female—9/16, 3/4, 1 1/8 in.
 - Medium-pressure—1/4, 3/8, 1/2 in.
 - Female NPT—1/4 in.
- Manual and pneumatically actuated valves

Features

- Weep holes for leak detection.
- Packing below stem threads.
- Nonrotating stem design.
- Straight thread high-pressure female or female NPT end connections.
- Available for sour gas applications. Materials are selected in accordance with NACE MR0175/ISO15156.

Pressure-Temperature Ratings

- 410 series ratings are based on Grafoil packing. Ratings are limited to 450°F (232°C) with glass-filled PTFE packing.
- 445, 645, and 945 series ratings are based on glass-filled PTFE packing. Ratings with Grafoil packing are equal to 410 series ratings.

Series	410	445, 645, 945
Temperature, °F (°C)	Working Pressure, psig (bar) ^①	
-65 (-53) to 100 (37)	15 000 (1034)	45 000 (3100)
200 (93)	13 930 (960)	41 800 (2880)
300 (148)	12 580 (867)	37 700 (2597)
400 (204)	11 550 (796)	34 600 (2383)
450 (232)	11 150 (769)	33 400 (2301)
500 (260)	7 165 (493)	—
550 (287)	6 970 (480)	
600 (315)	6 770 (466)	
650 (343)	6 660 (458)	
700 (371)	6 480 (446)	—
750 (398)	6 335 (436)	
800 (426)	6 230 (429)	
850 (454)	6 085 (419)	

① Working pressure determined based on ASME B31.3 Process Piping, Chapter IX High Pressure Piping.

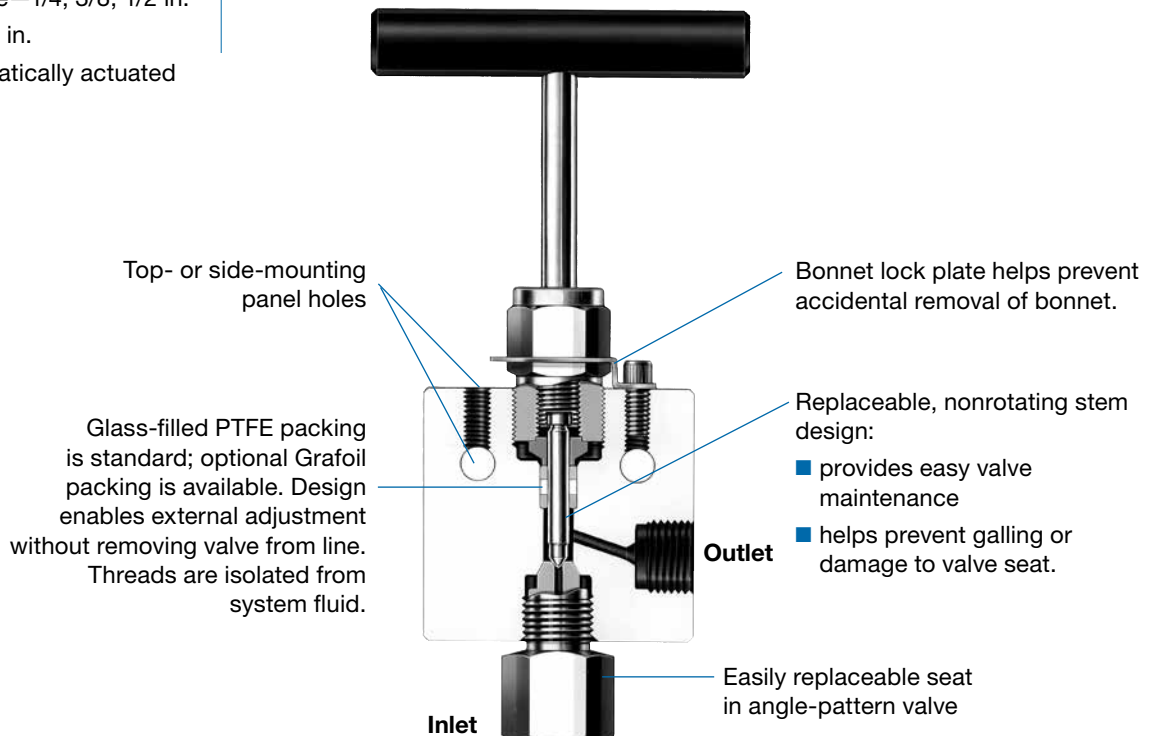

Materials of Construction

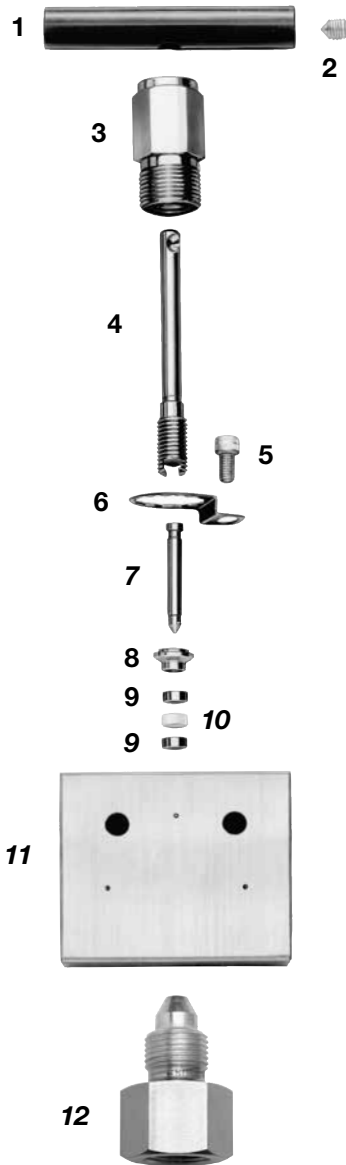

Component	Material Grade/ ASTM Specification
1 Handle (410) (445, 645, 945)	Red anodized aluminum 2024-T4/B211 Black anodized aluminum 2024-T4/B211
2 Handle screw	Cadmium-plated carbon steel
3 Bonnet nut	Phosphor bronze 544/B139
4 Stem shank	455 SS/A564
5 Lock screw	316 SS
6 Lock plate	316 SS/A240
7 Stem	440C SS/A276
8 Spacer	316 SS/A276
9 Gland	316 SS/A276
10 Packing	Glass-filled PTFE
11 Body	316 SS/A479
12 Replaceable seat (angle pattern)	316 SS/A479 with silver-plated threads
Lubricant	Copper/molybdenum disulfide

Wetted components listed in *italics*.

Flow Coefficient at Turns Open

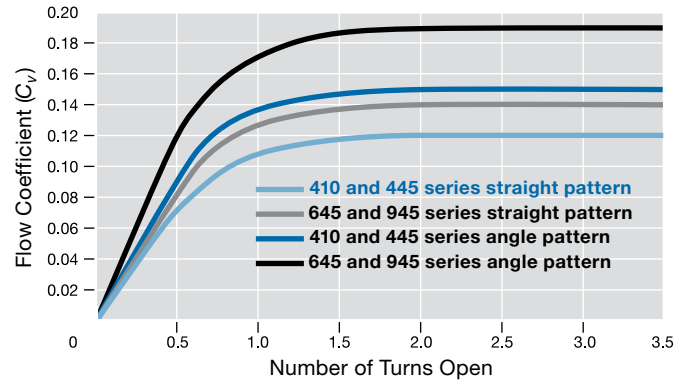

Operating Torque

Torque required for shutoff at maximum pressure rating is 50 in.·lb (5.7 N·m). Overtightening of valve will result in reduced seat life.

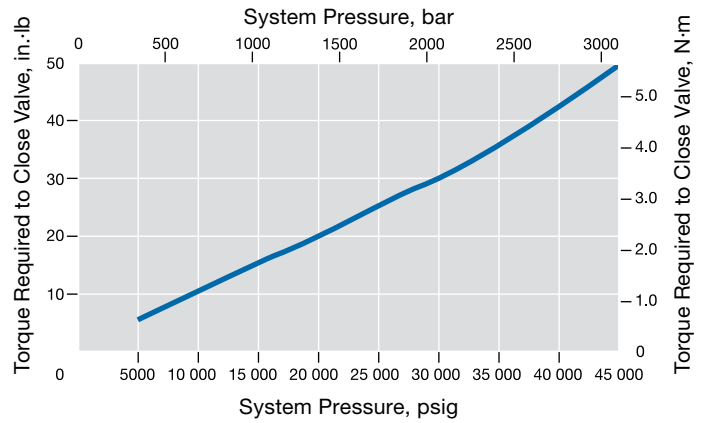

Testing

Every Swagelok high-pressure needle valve is factory tested with water up to its maximum pressure rating to a requirement of no detectable leakage at the seat and packing. Leak testing with gas is available; see page 1153.

Ordering Information and Dimensions

Dimensions, in inches (millimeters), are for reference only and are subject to change.

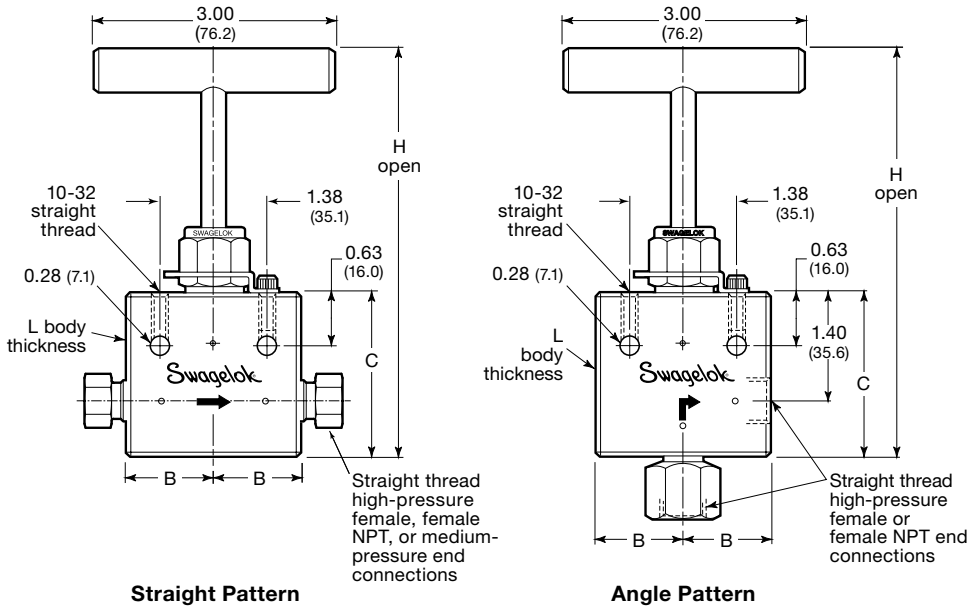

Valve Size in.	End Connection	Ordering Number	Series	C _v	Dimensions, in. (mm)				
					Orifice	B	C	H	L
Straight Pattern									
1/4	1/4 in. female NPT	SS-410-FP	410	0.12	0.093 (2.4)	1.07 (27.2)	2.02 (51.3)	4.91 (125)	1.03 (26.2)
	9/16-18 straight thread	SS-445-FP	445						
	1/4 in. medium-pressure fitting	SS-445-FK4	445						
3/8	3/4-16 straight thread	SS-645-FP	645	0.14	0.093 (2.4)	1.39 (35.3)	2.27 (57.7)	5.16 (131)	1.03 (26.2)
	3/8 in. medium-pressure fitting	SS-645-FK6	645						
9/16	1 1/8-12 straight thread	SS-945-FP	945	0.14	0.093 (2.4)	1.39 (35.3)	2.58 (65.5)	5.47 (139)	1.52 (38.6)
	1/2 in. medium-pressure fitting	SS-945-FK8	945						
Angle Pattern									
1/4	1/4 in. female NPT	SS-410-FPAR	410	0.15	0.093 (2.4)	1.39 (35.3)	2.27 (57.7)	5.47 (139)	1.03 (26.2)
	9/16-18 straight thread	SS-445-FPAR	445						
3/8	3/4-16 straight thread	SS-645-FPAR	645	0.19	0.093 (2.4)	1.39 (35.3)	2.27 (57.7)	5.16 (131)	1.03 (26.2)
9/16	1 1/8-12 straight thread	SS-945-FPAR	945						

Pneumatically Actuated Valves

Pneumatically actuated valves are designed for remote actuation where manual actuation is difficult or impractical. Pneumatic actuators are available in normally open, normally closed, and double acting modes.

Pressure-Temperature Ratings

To prolong valve life, actuators should be operated at minimum required pneumatic actuator pressures. Ratings for high-pressure valve actuators are:

- 200 psig at 100°F (13.7 bar at 37°C)
- 150 psig at 300°F (10.3 bar at 148°C)

Actuator Pressure at System Pressure

Normally open actuators require a minimum system pressure of 2500 psig (172 bar).

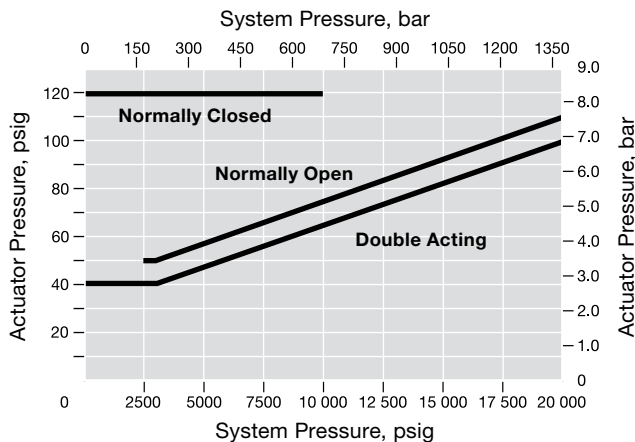

The pressure values shown above are based on the following valve criteria:

- **Valve contains glass-filled PTFE packing.** Other packing materials may substantially alter the force required to actuate the stem.
- **Proper bonnet nut adjustment.** If the bonnet nut is overtightened, the actuating pressure cannot overcome the frictional force between the packing and the stem. Sufficient bonnet nut torque should be maintained to prevent packing leakage while allowing proper actuation.
- **Liquid systems.** While high-pressure gas service generally requires the packing to be tightened, overtightening will prevent proper operation of the actuator.
- **Proper stem nut adjustment.** Stem position affects the spring force on the normally closed and normally open models.

Detailed service and adjustment instructions are included with each pneumatically actuated valve.

⚠ Caution: Actuated assemblies must be properly supported. Inadequate or improper support of the actuated assembly may result in leakage or premature valve failure.

Materials of Construction

Component	Double Acting (-D) and Normally Open (-O)	Normally Closed (-C)
Cylinder, cover, piston, mounting plate, tie rods, tie rod nuts	Black-anodized aluminum	
Piston rod, stem adjustment nut, stem lock nut	416 SS	
Piston rod nut, bonnet nut	316 SS	
Cover screws	Cadmium-plated steel	302 SS
O-rings	Fluorocarbon FKM	
Springs (-O, -C)	302 SS	
Piston rod bushing	—	Bronze

Ordering Information and Dimensions

Dimensions, in inches (millimeters), are for reference only and are subject to change.

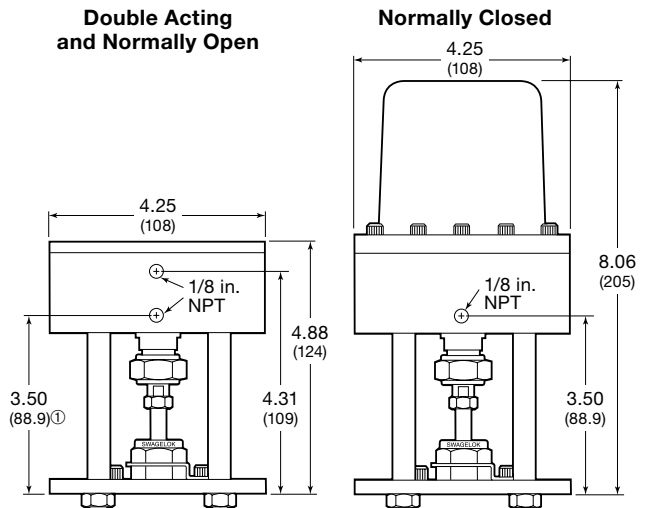

① Double-acting actuator only.

To order valves with a factory-assembled pneumatic actuator, add the actuator mode designator to a valve ordering number.

Actuation Mode	Designator
Normally closed	-C
Double acting	-D
Normally open	-O

Example: SS-410-FP-C

Options and Accessories

Stem Options

Valves are standard with 440C stainless steel stems. To order valves with optional stems, add a stem material designator to the valve ordering number.

Stem Material	Designator
440C SS with cobalt-based alloy tip	-STE
S17400 SS	-174

Example: SS-410-FP-**STE**

High-Temperature Stem Packing

Grafoil stem packing is available for temperatures up to 850°F (454°C). To order valves with factory-assembled Grafoil packing, add **-G** to the valve ordering number.

Example: SS-410-FP-**G**

Stem Packing Kits

PTFE and Grafoil stem packing kits are available for all series. Kits contain glands, packing, lubricants, and instructions.

Stem Packing	Kit Ordering Number
PTFE	T-91K-445
Grafoil	G-91K-445

Replaceable Seats

Angle-pattern valves have a one-piece replaceable seat with an integral female NPT or female straight thread high-pressure end connection. Seats are manufactured from 316 stainless steel and have silver-plated threads. To order a replaceable seat, select an ordering number.

Valve	Replaceable Seat Ordering Number
SS-410-FPAR	SS-410-RS-4F
SS-445-FPAR	SS-445-RS-44F
SS-645-FPAR	SS-645-RS-64F
SS-945-FPAR	SS-945-RS-94F

For proper assembly of a replaceable seat, tighten one-eighth turn past finger-tight with a wrench.

Optional Gas Seat Test

Leak testing with nitrogen at 5000 psig (344 bar) is available. Seats have a maximum allowable leak rate of 0.5 std cm³/min. To order, add **-PU** to the valve ordering number.

Example: SS-410-FP-**PU**

Stainless Steel Bar Handles

To order valves with factory-assembled 316 stainless steel bar handles, add **-SH** to the valve ordering number.

Example: SS-410-FP-**SH**

Spare Handles

To order handles as spare parts, select an ordering number.

Valve Series	Handle Ordering Numbers	
	Aluminum Bar	316 SS Bar
410	A-5K-410-RD	SS-51S-26B
445	A-5K-445-BK	
645 945		

Sour Gas Valves

Valves for sour gas service are available. Materials are selected in accordance with NACE MR0175/ISO 15156. The valves have annealed bodies and S17400 stems. The 410 series valves are rated to 10 000 psig (689 bar) rating. The 445, 645, and 945 series valves are rated to 18 000 psig at 100°F (1240 bar at 37°C) with high-pressure ports. To order, add **-SG** to the valve ordering number.

Example: SS-410-FP-**SG**

For more information on valves for sour gas service, contact your authorized Swagelok representative.

- ⚠ **A packing adjustment may be required periodically to increase service life and to prevent leakage.**
- ⚠ **Valves that have not been cycled for a period of time may have a higher initial actuation torque.**
- ⚠ **To increase service life, ensure proper valve performance, and prevent leakage, apply only as much torque as is required to achieve positive shutoff.**

Block and Bleed Valves —IPT Series

For pressures up to 20 000 psig
(1378 bar)



- 316 stainless steel construction
- Pressure rating: Up to 20 000 psig (1378 bar)
- Temperatures up to 650°F (121°C)
- Female NPT end connection sizes: 1/4 to 1 in.
- Medium-pressure cone and thread end connection sizes: 1/4 to 1 in.
- High-pressure cone and thread end connection sizes: 1/4, 3/8, and 9/16 in.
- Swagelok medium-pressure tube fitting (FK)

Features

- Two configurations available:
 - Single block and bleed (needle/needle)
 - Double block and bleed (ball/needle/ball or needle/needle/needle).
- Double block and bleed configuration allows for double positive isolation.
- Vee stem vent valve.

Important Information About Ball Valves

- ⚠ A packing adjustment may be required periodically to increase service life and to prevent leakage.
- ⚠ Valves that have not been cycled for a period of time may have a higher initial actuation torque.
- ⚠ To avoid damage and over-actuation, do not attempt to actuate past positive stop

Features

IPT series trunnion-style ball design

- seals consistently across a full range of pressures, even if system is depressurized and repressurized
- ensures reliable operation for improved actuation of control systems.

Ball/Needle/Ball Configuration

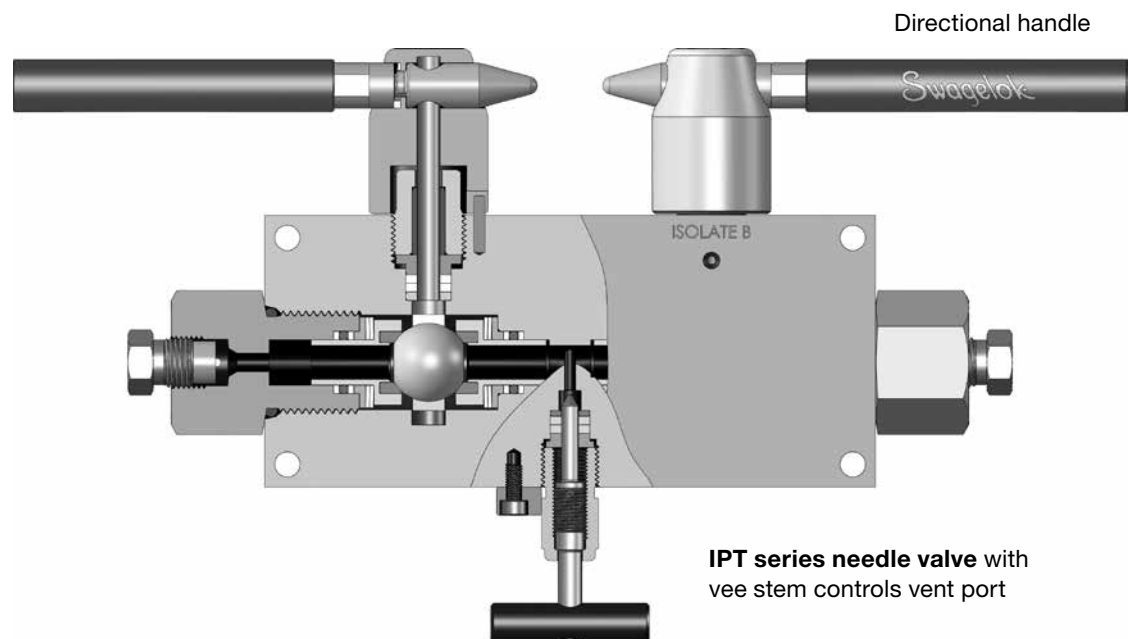

Shown with cone and thread end connections

Pressure-Temperature Ratings

Ball/Needle/Ball – 316 Stainless Steel with Fluorocarbon FKM O-Rings		
Temperature °F (°C)	End Connection	Working Pressure, psig (bar) ^{①②}
0 (-17) to 250 (121)	FNPT: 3/4 in. and 1 in.	10 000 (689)
	FNPT: 1/4 in. and 1/2 in.	15 000 (1034)
	Swagelok medium-pressure tube fitting 1/4 in. to 3/4 in.	15 000 (1034)
	Medium Pressure and High Pressure C&T	15 000 (1034)

① Working pressure determined based on ASME B31.3 Process Piping, Chapter IX High Pressure Piping.

② Pressure ratings may derate based upon the chosen end connection.

Needle/Needle and Needle/Needle/Needle - 316 Stainless Steel		
Temperature °F (°C)	End Connection	Working Pressure, psig (bar) ^{①②}
-40 (-40) to 250 (121) ^③	FNPT: 1/4 in. to 1/2 in.	15 000 (1034)
	FNPT: 3/4 in. and 1 in.	10 000 (689)
	Swagelok medium-pressure tube fitting 1/4 in. to 3/4 in.	20 000 (1378)
	Medium Pressure and High Pressure C&T	20 000 (1378)
250 (121) to 300 (148) ^④	FNPT: 1/4 in. to 1/2 in.	14 400 (992)
	FNPT: 3/4 in. and 1 in.	9 600 (661)
	Swagelok medium-pressure tube fitting 1/4 in. to 3/4 in.	19 200 (1323)
	Medium Pressure and High Pressure C&T	19 200 (1323)
300 (148) to 650 (343) ^④	FNPT: 1/4 in. to 1/2 in.	13 950 (992)
	FNPT: 3/4 in. and 1 in.	9 300 (641)
	Swagelok medium-pressure tube fitting 1/4 in. to 3/4 in.	18 600 (1282)
	Medium Pressure and High Pressure C&T	18 600 (1282)

① Working pressure determined based on ASME B31.3 Process Piping, Chapter IX High Pressure Piping.

② Pressure ratings may derate based upon the chosen end connection.

③ Ratings are limited to: 250°F (121°C) max with reinforced PTFE stem packing.

④ Ratings are based on manual needle valves with optional Grafoil packing.

Testing

Every Swagelok IPT series block-and-bleed valve is factory tested with water at the maximum working pressure for 60 seconds. Shell and seat testing is performed to a requirement of no visible leakage.

Cleaning and Packaging

Every block-and-bleed valve is cleaned in accordance with Swagelok *Standard Cleaning and Packaging (SC-10)* (MS-06-62), page 1174.

Materials of Construction

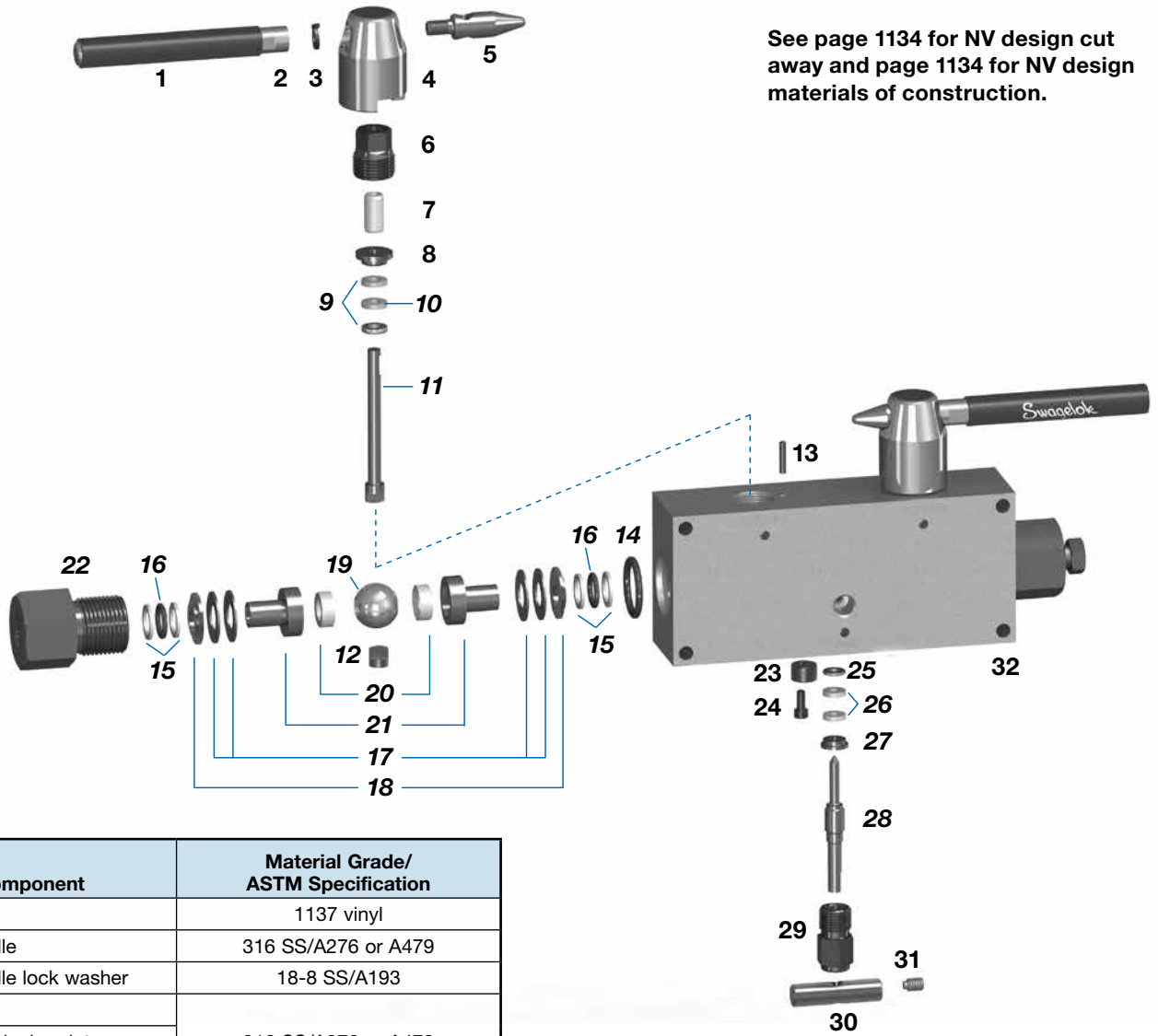

See page 1134 for NV design cut away and page 1134 for NV design materials of construction.

Component	Material Grade/ ASTM Specification
1 BV Grip	1137 vinyl
2 BV Handle	316 SS/A276 or A479
3 BV Handle lock washer	18-8 SS/A193
4 BV Hub	316 SS/A276 or A479
5 BV stem lock pointer	
6 BV packing gland	Reinforced PEEK
7 BV bearing sleeve	316 SS/A276 or A479
8 BV top packing washer	Reinforced PTFE
9 BV packing ring	316 SS/A276 or A479
10 BV bottom packing washer	S17400/A564, Type 630
11 BV stem	316 SS/A276 or A479
12 BV support tab	
13 Stop pin	316 SS
14 Seat carrier O-ring	Fluorocarbon FKM
15 Backup washer	Reinforced PEEK
16 O-ring	Fluorocarbon FKM
17 Seat springs	316 SS/A276 or A479
18 Follower	
19 BV ball	Reinforced PEEK
20 Seat seal	316 SS/A276 or A479
21 Seat carrier	
22 End screw	

Component	Material Grade/ ASTM Specification
23 NV locking device	316L SS/A276
24 Socket head cap screw	18-8 SS/A193
25 NV bottom packing washer	316 SS/A276 or A479
26 NV packing	Reinforced PTFE
27 NV top packing washer	316 SS/A276 or A479
28 NV vee stem	S17400/A564, Type 630
29 NV packing gland	316 SS/A276 or A479
30 NV handle	303 SS/A5640
31 NV handle set screw	18-8 SS/A193
32 Body	316 SS/A276 or A479
Wetted lubricants	Silicone-based, tungsten disulfide additive
Nonwetted lubricants	Hydrocarbon-based

Wetted components listed in *italics*.
BV = ball valve component; NV = needle valve component.

Options

O-Ring Materials

Optional O-ring materials are available for all IPT series ball/needle/ball double block and bleed valves shown below. To order, add the optional O-ring material designator to the valve ordering number.

Examples:

Optional HNBR O-ring: DB9M4M2V15-**H**

Optional perfluorocarbon FFKM O-ring: DB9M4M2V15-**C**

O-Ring Material	Temperature Rating °F (°C)	Designator
HNBR	0 to 250 (-17 to 121)	-H
Perfluorocarbon FFKM	20 to 185 (-6 to 85)	-C

Dimensions

Dimensions, shown with coned and thread fitting nuts finger-tight, are for reference only and are subject to change. For additional dimensions of valve configurations, contact your authorized Swagelok representative.

Typical Ball/Needle/Ball Configuration with Medium-Pressure Cone & Thread Connections

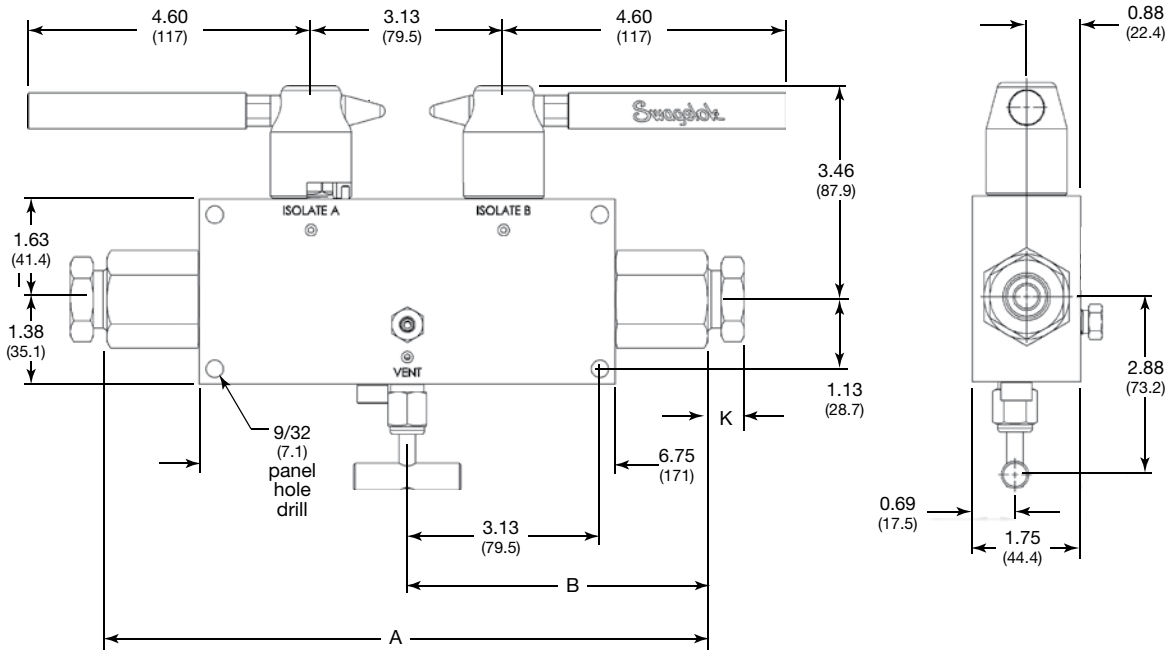

End Connections		Vent Port Size/Style	Typical Ordering Number	Orifice in. (mm)	Flow Coefficient (C_v)	Dimensions, in. (mm)		
Inlet/Outlet	Size					A	B	K
15 000 psig (1034 bar)								
Female medium- pressure cone & thread	1/4 in.	1/4 in. female medium- pressure cone & thread	DB4M4M2V15	0.375 (9.5)	0.2	8.65 (220)	4.33 (110)	0.38 (9.7)
	3/8 in.		DB6M4M2V15		0.9	8.81 (224)	4.41 (112)	0.48 (12.2)
	9/16 in.		DB9M4M2V15		2.5	9.35 (238)	4.67 (119)	0.68 (17.3)
	3/4 in.		DB12M4M2V15		3.5	9.75 (248)	5.15 (131)	0.59 (15.0)
	1 in.		DB16M4M2V15		3.5	10.5 (267)	5.26 (134)	0.74 (18.8)

Dimensions

Dimensions, shown with coned and thread fitting nuts finger-tight, are for reference only and are subject to change. For additional dimensions of valve configurations, contact your authorized Swagelok representative.

Typical Needle/Needle/Needle Configuration with Medium-Pressure Cone & Thread Connections

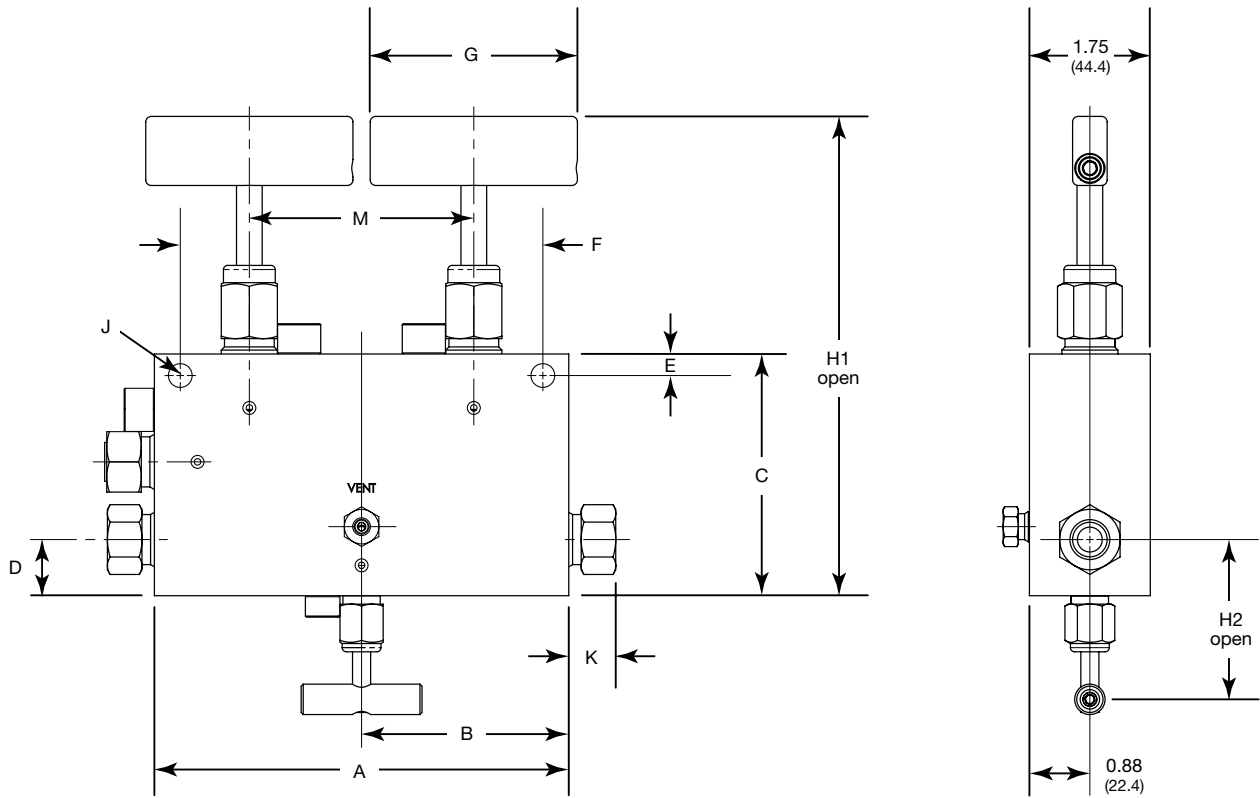

End Connections		Vent Port Size/Style	Typical Ordering Number	Orifice in. (mm)	Dimensions, in. (mm)					
Inlet/Outlet	Size				A	B	C	D	E	F
15 000 psig (1034 bar)										
Female medium-pressure cone & thread	1/4 in.	1/4 in. female medium-pressure cone & thread	DB4M4M1V20	0.12 (3.0)	4.00 (102)	2.00 (50.8)	2.00 (50.8)	0.37 (9.4)	0.25 (6.4)	3.50 (88.9)
	3/8 in.		DB6M4M1V20	0.20 (5.1)	5.50 (140)	2.75 (69.8)	3.00 (76.2)	0.87 (22.1)		5.00 (127)
	9/16 in.		DB9M4M1V20	0.31 (7.9)	6.00 (152)	3.00 (76.2)	3.50 (88.9)	0.81 (20.6)	0.31 (7.9)	5.24 (133)
					G	H1	H2	J	K	M
Female medium-pressure cone & thread	1/4 in.	1/4 in. female medium-pressure cone & thread	DB4M4M1V20	0.12 (3.0)	1.75 (44.4)	3.74 (95.0)	1.87 (47.5)	0.28 (7.1)	0.38 (9.7)	2.25 (57.2)
	3/8 in.		DB6M4M1V20	0.20 (5.1)	3.00 (76.2)	5.42 (138)	2.37 (60.2)		0.48 (12.2)	3.25 (82.6)
	9/16 in.		DB9M4M1V20	0.31 (7.9)	6.94 (176)	2.31 (58.7)	0.34 (8.6)	0.68 (17.3)		

Needle/Needle/Needle Double Block and Bleed

Plugged port required for machining, not an end connection

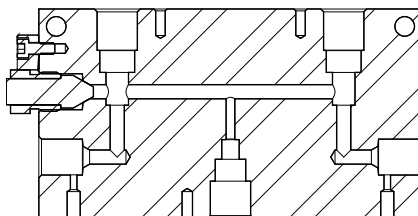

Needle/Needle Single Block and Bleed

Bottom bleed port (standard)

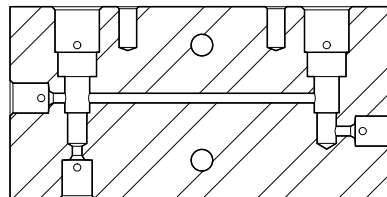

Needle/Needle Single Block and Bleed

Side bleed port (use -SB suffix when ordering)

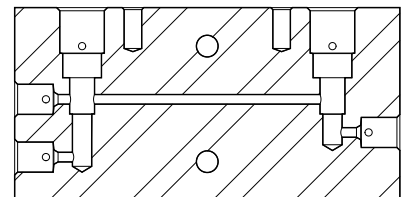

Ordering Information

Build a valve ordering number by combining the designators in the sequence shown below.

1 2 3 4 5 6 7 8 9 10
DB 9 M 6 M 1 V 20 - H - GR

1 Configuration

DB = Double block/bleed
SB = Single block/bleed

2 End Connection Size

4 = 1/4 in.
6 = 3/8 in.
8 = 1/2 in. (FK, FNPT only)
9 = 9/16 in. (FK, C&T only)
12 = 3/4 in. (FK, FNPT, and MP C&T only)
16 = 1 in. (FNPT and MP C&T only)

3 End Connection Style

M = Female MP C&T
H = Female HP C&T
N = Female NPT
FK = MP Tube Fitting

4 Vent Connection Size

4 = 1/4 in.
6 = 3/8 in.
8 = 1/2 in. (FNPT, single block and bleed only)
9 = 9/16 in. (C&T, single block and bleed only)

5 Vent Connection Style

M = Female MP C&T
H = Female HP C&T
N = Female NPT
FK = MP Tube Fitting

6 Style

Double block/bleed
1 = Needle/needle/needle
2 = Ball/needle/ball
Single block/bleed
1 = Needle/needle

7 Stem Type

V = Vee
R = Regulating

8 Pressure Rating

10 = 10 000 psig (689 bar)
15 = 15 000 psig (1034 bar)
20 = 20 000 psig (1378 bar)

9 O-Ring (ball/needle/ball)

None = Fluorocarbon FKM, standard
H = HNBR
C = Perfluorocarbon FFKM

10 Options

GR = Grafoil Packing (needle valves)
SB = Side Bleed (single block)
N50 = Nitronic 50 Stem Material (needle valves)

Maintenance Kits

For maintenance kit information, contact your authorized Swagelok representative.

Check Valves—IPT Series

For Pressures up to 60 000 psig (4134 bar)



- 316 stainless steel construction
- Pressure rating: Up to 60 000 psig (4134 bar)
- Temperatures up to 650°F (343°C)
- Female NPT end connection sizes: 1/4 to 1 in.
- Cone and thread end connection sizes: 1/4 to 1 in.
- Nominal cracking pressure: 15 psi (1.0 bar)
- Swagelok medium-pressure tube fitting (FK) end connection sizes 1/4 to 3/4 in. (available on soft seat and ball seal models only)

Features

- Three designs to fit most applications:
 - Ball-seal poppet—Metal-to-metal seat
 - Soft-seal poppet—O-ring seat; standard material is HNBR (hydrogenated nitrile butadiene rubber).
 - Dual-seal ball—Glass-filled PTFE seat, backed by metal-to-metal sealing.
- Nominal cracking pressure is 15 psi (1.0 bar); optional cracking pressure include 25 psi (1.7 bar), 50 psi (3.4 bar), 75 psi (5.2 bar) and 100 psi (6.9 bar).
- Available for sour gas applications. Materials are selected in accordance with NACE MR0175/ISO15156.

Pressure Ratings

End Connection		Check Valve Design					
		Ball-Seal Poppet		Soft-Seal Poppet		Dual-Seal Ball	
		Pressure Ratings ^① , psig (bar)					
Style	Size in.	Working Pressure	Maximum Back Pressure	Working Pressure	Maximum Back Pressure	Working Pressure	Maximum Back Pressure
Female NPT	1/8 to 1/2	15 000 (1034)	15 000 (1034)	15 000 (1034)	15 000 (1034)	15 000 (1034)	15 000 (1034)
	3/4 to 1	10 000 (689)	10 000 (689)	10 000 (689)	10 000 (689)	10 000 (689)	10 000 (689)
Medium-pressure tube fitting	1/4 to 3/4	20 000 (1378)	20 000 (1378)	20 000 (1378)	20 000 (1378)	—	—
Cone and thread	1/4 to 1	20 000 (1378)	20 000 (1378)	20 000 (1378)	20 000 (1378)	—	—
	1/4 to 3/8	60 000 (4134)	60 000 (4134)	60 000 (4134)	40 000 (2756)	—	—
	9/16	60 000 (4134)	60 000 (4134)	60 000 (4134)	60 000 (4134)	—	—

① Working pressure determined based on ASME B31.3 Process Piping, Chapter IX High Pressure Piping.

Temperature Ratings^①

Ball-seal poppet: -60 to 650°F (-51 to 343°C)

Soft-seal poppet: 0 to 250°F (-17 to 121°C) with standard HNBR seal

Dual-seal ball: 0 to 250°F (-17 to 121°C) with standard glass-filled PTFE seat

① Check valves with FK end connections include a PTFE coated stainless steel washer, temperature rating: 0 to 500°F (-17 to 260°C).

Elevated Temperature Factors

Ball-Seal Poppet Check Valve Only

To determine allowable working pressure at elevated temperatures, multiply allowable working pressures shown above by a factor shown in the table below.

Temperature		Factor
°F	°C	
-60 to 200	-51 to 121	1.00
300	148	0.96
400	204	0.93
500	260	
600	315	0.93
650	343	

Important Information About Check Valves

⚠ Check valves are designed for directional flow control only. Swagelok check valves should never be used as a code safety relief devices, isolation valves, or shut-off valves.

⚠ For valves not actuated for a period of time, initial cracking pressure may be higher than the set cracking pressure.

Soft-Seal Poppet Check Valve

Soft-Seal Poppet—O-ring seat for fast shut-off and a leak-tight seal; standard material is nitrile.

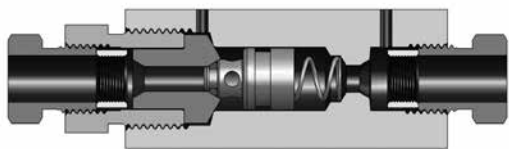

Materials of Construction

Component	Material Grade/ ASTM Specification
1 Body	316 SS/A276 or A479
2 Spring	302 SS/A313
3 Poppet	316 SS/A276 or A479
4 O-ring	Nitrile
5 Cover	316 SS/A276 or A479
6 Gland nut	316 SS/A276 or A479
Wetted lubricants	Silicone-based with tungsten disulfide additive
Nonwetted lubricants	Hydrocarbon-based

Wetted components listed in *italics*.



Shown with cone and thread end connections

Water Flow Data at 70°F (20°C)

Soft-Seal Poppet—Female C&T Connections

20 000 psig (1378 bar) Pressure Rating, 1/4 and 3/8 in.

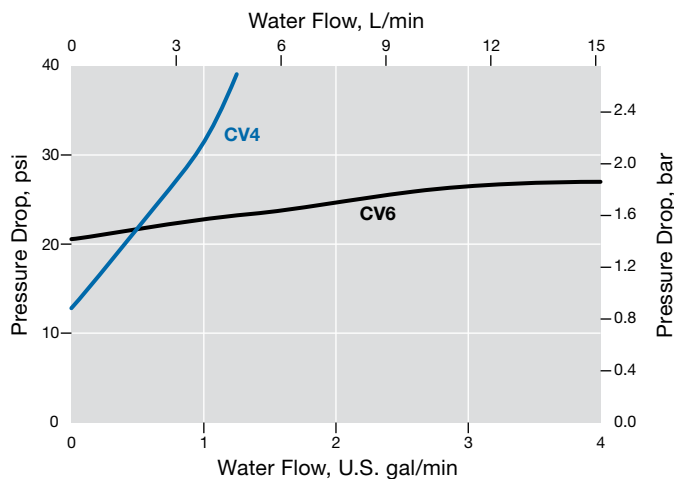

20 000 psig (1378 bar) Pressure Rating, 9/16 to 1 in.

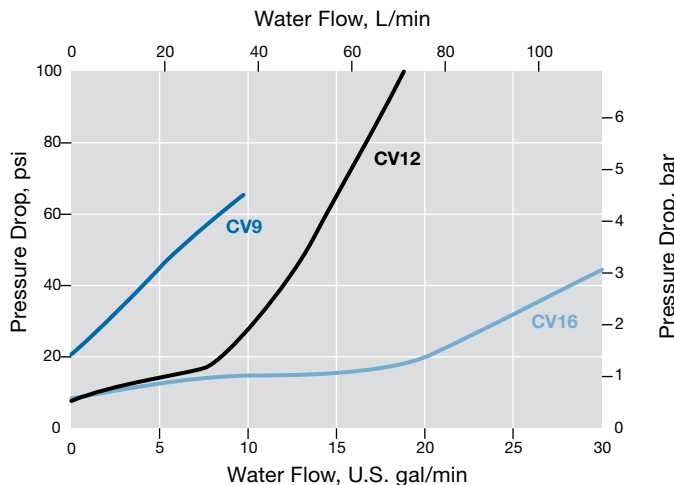

60 000 psig (4134 bar) Pressure Rating, 1/4 to 9/16 in.

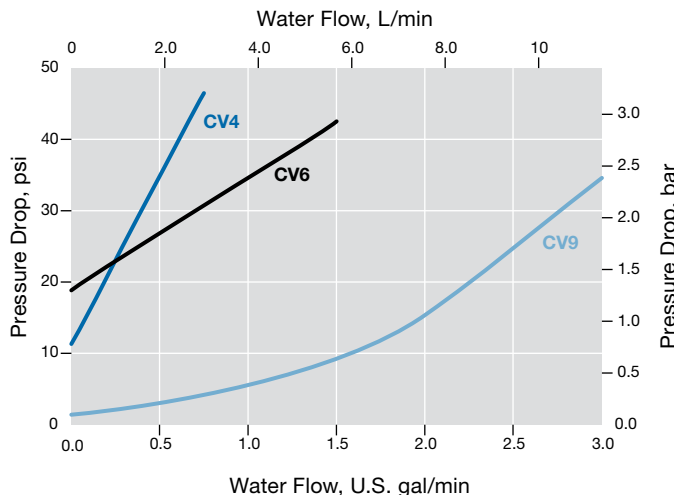

Water Flow Data at 70°F (20°C)

Soft-Seal Poppet—Female NPT Connections

15 000 psig (1034 bar) Pressure Rating, 1/4 to 1/2 in.

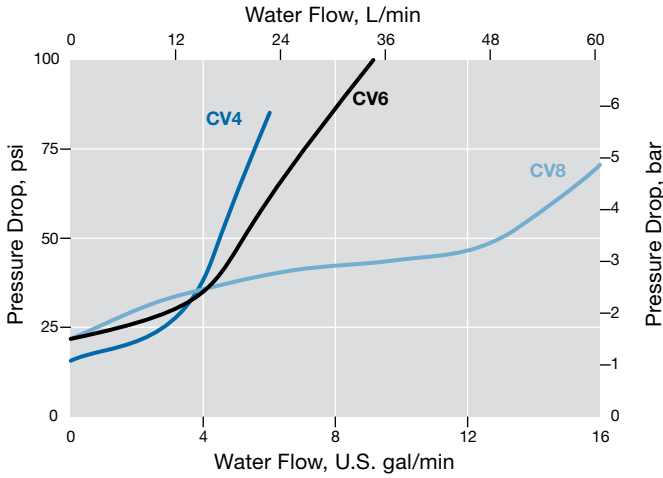

10 000 psig (689 bar) Pressure Rating, 3/4 and 1 in.

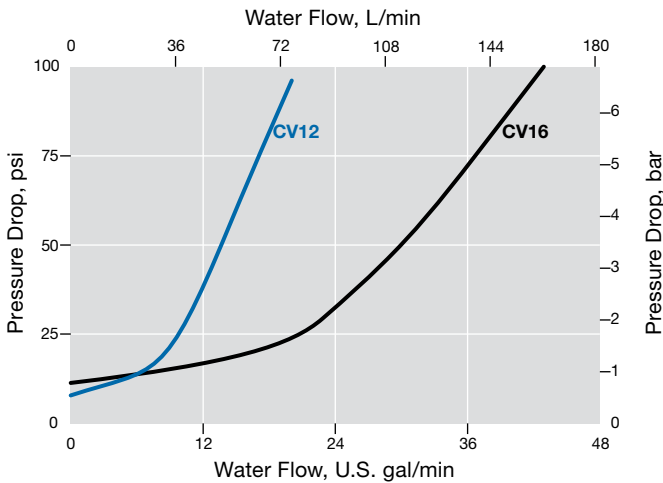

Ordering Information and Dimensions

Dimensions, shown with coned and thread collar and glands finger-tight, are for reference only and are subject to change.

Ordering numbers shown have a standard cracking pressure of 15 psi (1.0 bar) and HNBR O-ring material. See Options to order valves with other cracking pressures and O-ring materials.

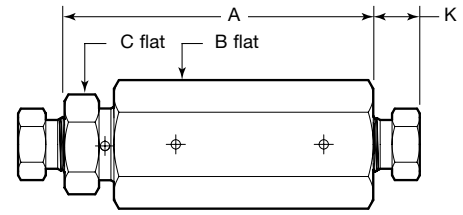

Soft-Seal Poppet Check Valve

End Connections		Ordering Number	C _v	Dimensions in. (mm)			
Type	Size			A	B	C	K
10 000 psig (689 bar)							
Female NPT	3/4 in.	CV12NFS10	2.0	5.94 (151)	1 3/4	1 1/2	—
	1 in.	CV16NFS10	4.2	7.28 (185)	2 1/8	1 3/4	—
15 000 psig (1034 bar)							
Female NPT	1/4 in.	CV4NFS15	0.65	2.91 (73.8)	3/4	3/4	—
	3/8 in.	CV6NFS15	0.91	3.55 (90.2)	1 1/8	1	—
	1/2 in.	CV8NFS15	1.9	4.62 (117)	1 3/8	1 3/8	—
20 000 psig (1378 bar)							
Female Cone and Thread	1/4 in.	CV4MFS20	0.20	2.94 (74.7)	1	7/8	0.38 (9.7)
	3/8 in.	CV6MFS20	0.77	3.13 (79.5)	1 1/8	7/8	0.48 (12.2)
	9/16 in.	CV9MFS20	1.2	4.22 (107)	1 3/8	1 3/8	0.68 (17.3)
	3/4 in.	CV12MFS20	1.8	5.89 (150)	1 3/4	1 3/8	0.59 (15.0)
	1 in.	CV16MFS20	4.5	6.49 (165)	2 1/8	1 3/4	0.74 (18.8)
60 000 psig (4134 bar)							
Female Cone and Thread	1/4 in.	CV4HFS60	0.11	3.33 (84.6)	1 1/8	7/8	0.59 (15.0)
	3/8 in.	CV6HFS60	0.23	3.75 (95.3)	1 3/8	1 1/8	0.72 (18.3)
	9/16 in.	CV9HFS60	0.51	4.60 (117)	1 1/2	1 3/8	1.00 (25.4)

For valves with Swagelok medium-pressure tube fitting connections, contact your authorized Swagelok representative.

Ball-Seal Poppet Check Valve

Ball-Seal Poppet—Metal-to-metal seat for rapid cycling or severe environments where leak-tight shutoff is not required.

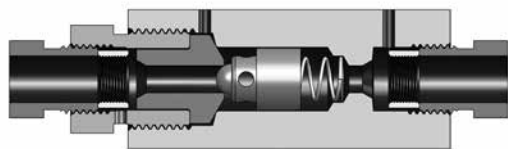

Materials of Construction

Component	Material Grade/ ASTM Specification
1 Body	316 SS/A276 or A479
2 Spring	302 SS/A313
3 Poppet	S17400/A564, Type 630
4 Cover	316 SS/A276 or A479
5 Gland nut	316 SS/A276 or A479
Wetted lubricant	<i>Silicone-based with tungsten disulfide additive</i>
Nonwetted lubricants	Hydrocarbon-based

Wetted components listed in *italics*.

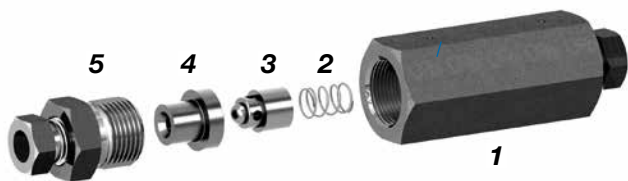

Shown with cone and thread end connections

Water Flow Data at 70°F (20°C)

Ball-Seal Poppet—Female C&T Connections

20 000 psig (1378 bar) Pressure Rating, 1/4 and 3/8 in.

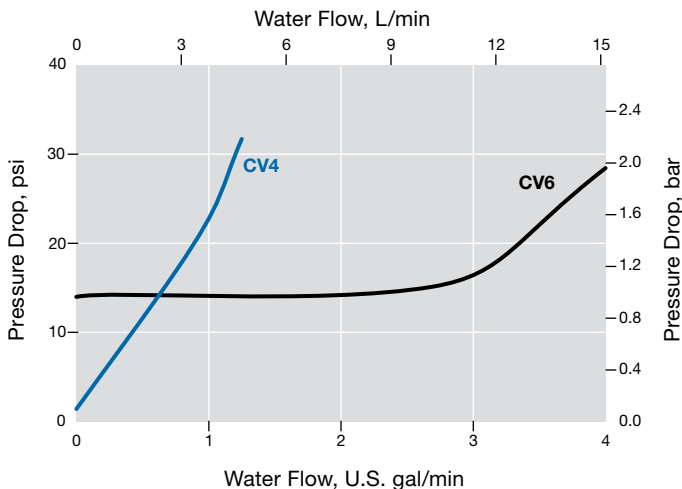

20 000 psig (1378 bar) Pressure Rating, 9/16 to 1 in.

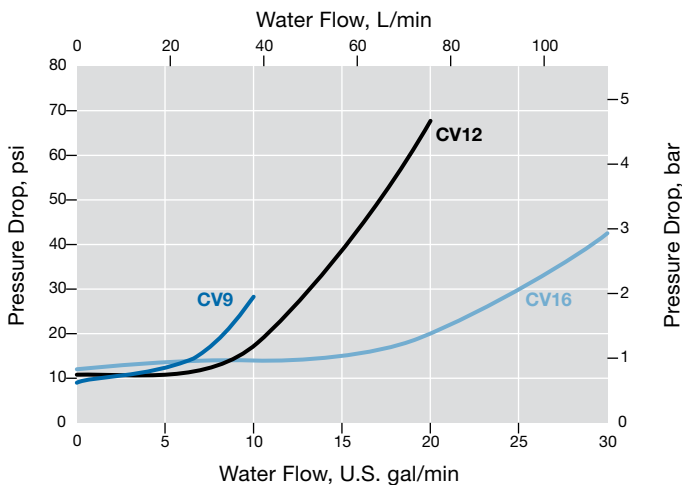

60 000 psig (4134 bar) Pressure Rating, 1/4 to 9/16 in.

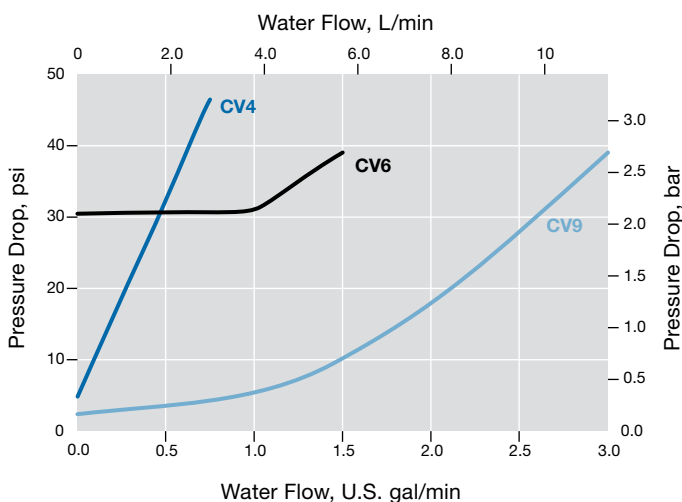

Water Flow Data at 70°F (20°C)

Ball-Seal Poppet—Female NPT Connections

15 000 psig (1034 bar) Pressure Rating, 1/4 to 1/2 in.

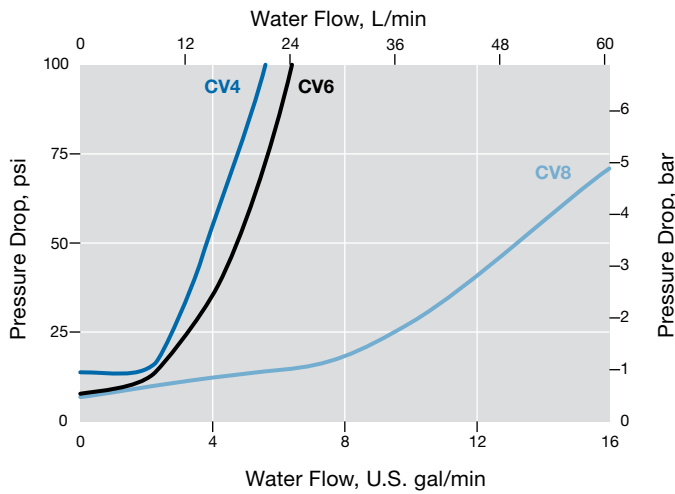

10 000 psig (689 bar) Pressure Rating, 3/4 and 1 in.

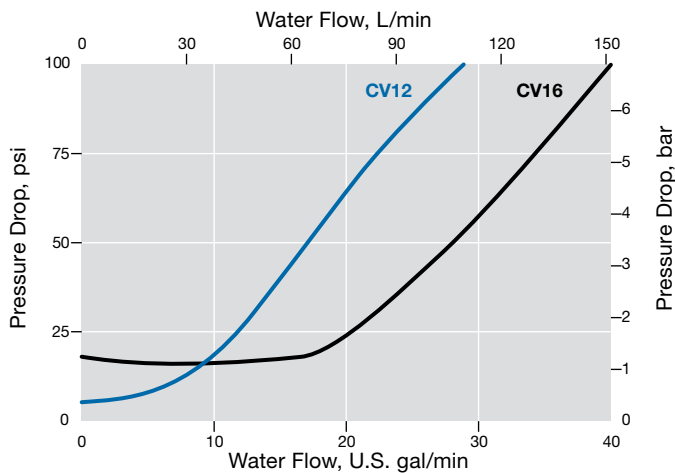

Ordering Information and Dimensions

Dimensions, shown with coned and thread collars and glands finger-tight, are for reference only and are subject to change.

Ordering numbers shown have a standard cracking pressure of 15 psi (1.0 bar). See Options to order valves with other cracking pressures.

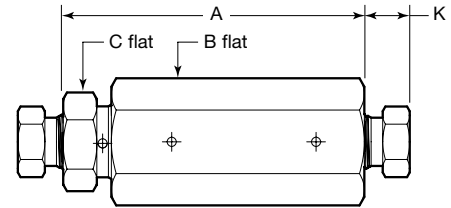

Ball-Seal Poppet Check Valve

End Connections		Ordering Number	C _v	Dimensions in. (mm)			
Type	Size			A	B	C	K
10 000 psig (689 bar)							
Female NPT	3/4 in.	CV12NFB10	2.8	5.88 (149)	1 3/4	1 1/2	—
	1 in.	CV16NFB10	4.0	7.28 (185)	2 1/8	1 3/4	—
15 000 psig (1034 bar)							
Female NPT	1/4 in.	CV4NFB15	0.56	2.91 (73.9)	3/4	3/4	—
	3/8 in.	CV6NFB15	0.61	3.54 (89.9)	1 1/8	1	—
	1/2 in.	CV8NFB15	1.9	4.59 (117)	1 3/8	1 3/8	—
20 000 psig (1378 bar)							
Female Cone and Thread	1/4 in.	CV4MFB20	0.22	2.92 (74.2)	1	7/8	0.38 (9.7)
	3/8 in.	CV6MFB20	0.25	3.12 (79.2)	1 1/8	7/8	0.48 (12.2)
	9/16 in.	CV9MFB20	1.8	4.22 (107)	1 3/8	1 3/8	0.68 (17.3)
	3/4 in.	CV12MFB20	2.4	5.89 (150)	1 3/4	1 3/8	0.59 (15.0)
	1 in.	CV16MFB20	4.6	6.49 (165)	2 1/8	1 3/4	0.74 (18.8)
60 000 psig (4134 bar)							
Female Cone and Thread	1/4 in.	CV4HFB60	0.11	3.31 (84.1)	1 1/8	7/8	0.59 (15.0)
	3/8 in.	CV6HFB60	0.24	3.74 (95.0)	1 3/8	1 1/8	0.72 (18.3)
	9/16 in.	CV9HFB60	0.48	4.57 (116)	1 1/2	1 3/8	1.00 (25.4)

For valves with Swagelok medium-pressure tube fitting connections, contact your authorized Swagelok representative.

Dual-Seal Ball Check Valve

Dual-Seal Ball—Leak-tight sealing on the glass-filled PTFE seat, backed by metal-to-metal sealing for durability.

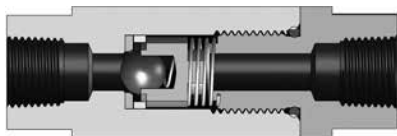

Materials of Construction

Component	Material Grade/ ASTM Specification
1 Body	316 SS/A276 or A479
2 Seat	Reinforced PTFE
3 Retaining ring	316 SS/A276 or A479
4 Ball	316 SS/A493
5 Ball spring	302 SS/ A313
6 Ball retainer	316 SS/A276 or A479
7 Retaining spring	302 SS/ A313
8 Spring retainer	316 SS/A276 or A479
9 Snap ring (except CV4)	15-7 SS/ASME B18.27.1
10 O-ring (CV4 only)	Fluorocarbon FKM
11 Gland (CV4 only)	316 SS/A276 or A479
Wetted lubricants	Silicone-based with tungsten disulfide additive
Nonwetted lubricants	Hydrocarbon-based

Wetted components listed in *italics*.

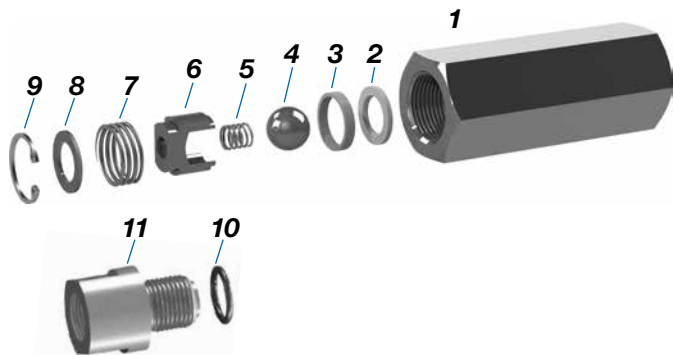

Water Flow Data at 70°F (20°C)

Dual-Seal Ball—Female NPT Connections

**10 000 psig (689 bar) and 15 000 psig (1034 bar)
Pressure Rating**

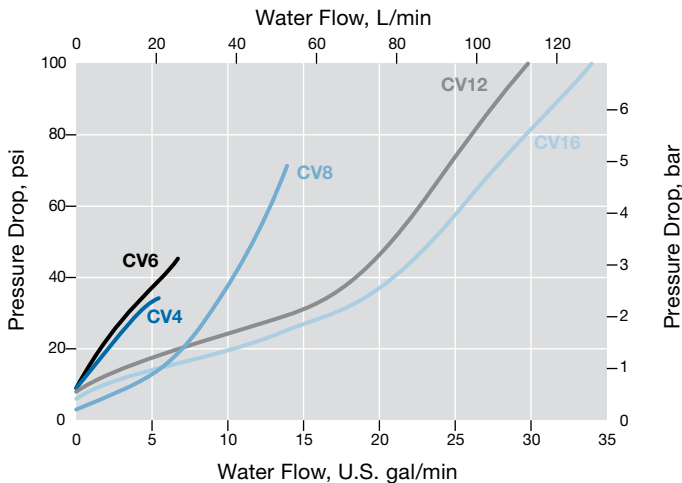

Ordering Information and Dimensions

Dimensions, shown with coned and thread fitting nuts finger-tight, are for reference only and are subject to change.

Ordering numbers shown have a standard cracking pressure of 15 psi (1.0 bar) and for the CV4 only, a fluorocarbon FKM O-ring.

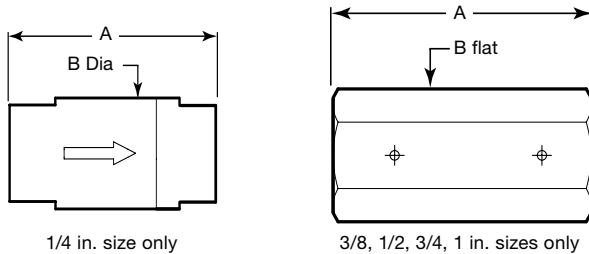

Dual-Seal Ball Check Valve

End Connections		Ordering Number	C _v	Dimensions in. (mm)	
Type	Size			A	B
10 000 psig (689 bar)					
Female NPT	3/4 in.	CV12NFD10	2.9	3.25 (82.6)	1 3/8
	1 in.	CV16NFD10	3.4	4.25 (108)	1 3/4
15 000 psig (1034 bar)					
Female NPT	1/4 in.	CV4NFD15	0.93	3.00 (76.2)	1
	3/8 in.	CV6NFD15	1.0	2.75 (69.8)	1
	1/2 in.	CV8NFD15	1.6	3.12 (79.2)	1 3/16

Testing

Every CV series check valve is tested with water at the maximum working pressure for 60 seconds. Shell testing is performed to a requirement of no visible leakage.

Cleaning and Packaging

Every CV series check valve is cleaned in accordance with Swagelok *Standard Cleaning and Packaging (SC-10)* (MS-06-62), page 1174.

Options

Cracking Pressures

Standard cracking pressure of soft-seal and ball-seal poppet check valves is 15 psi (1.0 bar). Optional cracking pressures of 25 psi (1.7 bar), 50 psi (3.4 bar), 75 psi (5.2 bar) and 100 psi (6.9 bar) are available, except for all 1/4 in. check valves and dual-seal ball check valves of any size.

To order, add **-25**, **-50**, **-75**, or **-100** to the ordering number.

Examples

Soft-seal check valve: CV12NFS10-**25**

Ball-seal check valve: CV12NFB10-**50**

O-Ring Materials

Optional O-ring materials are available for the soft-seal poppet check valves and dual-seal ball check valves (CV4 only).

O-Ring Material	Temperature Rating °F (°C)	Soft-Seal	Dual-Seal (CV4 Only)	Designator
Fluorocarbon FKM	0 to 250 (-17 to 121)	Optional	Standard	-F
HNBR	0 to 250 (-17 to 121)	Standard	Optional	-H
Perfluorocarbon FFKM	20 to 185 (-6 to 85)	Optional	Optional	-C

Ordering Information

If the O-ring materials is shown as standard for the check valve model, no designator is required. If the O-ring material is shown as optional for the check valve model, add the material designator to the check valve ordering number.

Examples

Soft-seal check valve with optional fluorocarbon FKM

O-ring: CV9MFS20-**F**

Dual-seal check valve (CV4) with optional HNBR O-ring:

CV4NFD15-**H**

NACE-Compliant Valves for Sour Gas Service

Ball Seal and Soft Seal Check valves are available for sour gas service. Materials are selected in accordance with NACE MR0175/ISO 15156. For more information on valves for sour gas service, contact your authorized Swagelok representative.

Maintenance Kit

Poppet and Spring Kit

Kit contains poppet and spring. To order, use **RK-** followed by the complete check valve ordering number.

Example: **RK-CV4MFB20**

Proportional Relief Valves— IPT Series

For Pressures up to 20 000 psig
(1378 bar)



- 316 stainless steel construction
- Working pressures up to 20 000 psig (1378 bar)
- Set pressures from 1000 to 20 000 psig (68.9 to 1378 bar)
- Temperatures up to 250°F (121°C)
- Female NPT end connection size: 3/4 in. (outlet)
- Cone and thread end connection 3/8 and 9/16 in. (inlet)
- Swagelok medium-pressure tube fitting (FK) 3/8, 1/2 and 9/16 in.
- For liquid service

Features

- Proportional relief valve; opens gradually as pressure increases.
- Choice of set or adjustable pressure operation.
- Adjustable pressure relief valves are available with a choice of 2 spring ranges: 1000 to 10 000 psig (68.9 to 689 bar) and 10 000 to 20 000 psig (689 to 1378 bar).
- Set pressure relief valves are available factory-set to a specified set pressure from 1000 to 20 000 (68.9 to 1378 bar) in 100 psig (6.9 bar) increments.

Pressure-Temperature Ratings

Temperature °F (°C)	316 Stainless Steel with Fluorocarbon FKM O-Rings		
	Working Pressure psig (bar) ^{①②}	Set Pressure psig (bar)	Back Pressure psig (bar)
0 (-17) to 250 (121)	20 000 (1378)	1000 to 20 000 (68.9 to 1378)	500 (34.4)

① Working pressure determined based on ASME B31.3 Process Piping, Chapter IX High Pressure Piping.

② Pressure ratings may derate based upon the chosen end connection.

Applications

IPT series relief valves are proportional relief valves that open gradually as the pressure increases. Consequently, they do not have a capacity rating at a given pressure rise (accumulation), and they are not certified to ASME or any other codes.

- ⚠ **Some system applications require relief valves to meet specific safety codes. The system designer and user must determine when such codes apply and whether these relief valves conform to them.**
- ⚠ **Swagelok proportional relief valves should never be used as ASME Boiler and Pressure Vessel Code safety relief devices.**
- ⚠ **Swagelok proportional relief valves are not “Safety Accessories” as defined in the Pressure Equipment Directive 97/23/EC.**

Operation

IPT series relief valves OPEN when system pressure reaches or exceeds the set pressure and CLOSE when system pressure falls below the set pressure.

- Each valve must have its own isolated exhaust and cannot be plumbed in series.

Set Pressure and Resealing Pressure

- Set pressure is the upstream pressure at which the first indication of flow occurs.
- Resealing pressure is the upstream pressure at which there is no indication of flow. Resealing pressure is always lower than set pressure.
- Pressure-temperature ratings are based upon laboratory testing to ensure that the crack pressure does not deviate more than 25% from the initial room-temperature set pressure.

- ⚠ **For valves not actuated for a period of time, initial relief pressure may be higher than the set pressure.**

Features

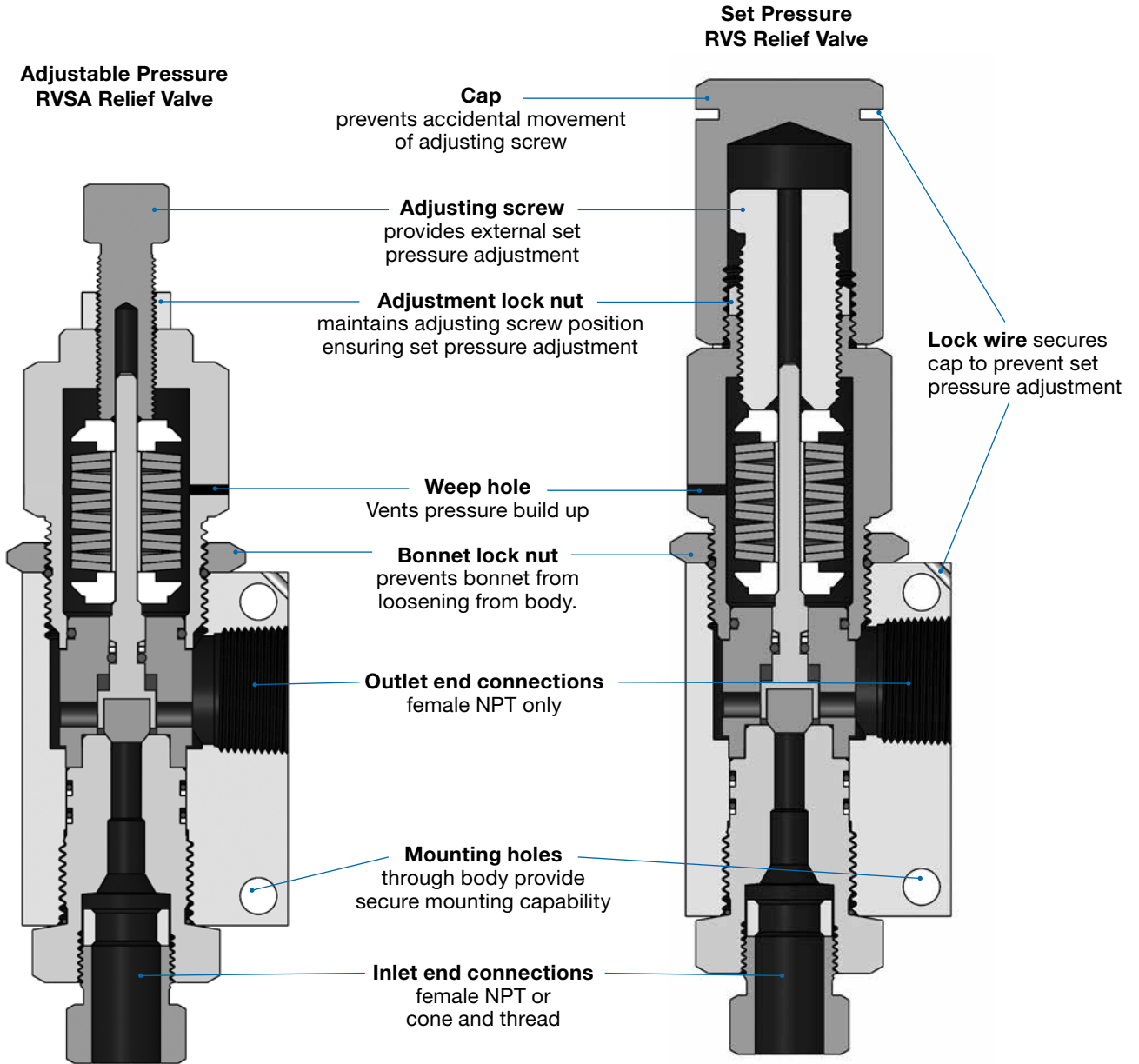

Testing

Every IPT series proportional relief valve is tested with water at the maximum set pressure to a requirement of no visible leakage past the seat.

Cleaning and Packaging

Every IPT series relief valve is cleaned in accordance with Swagelok *Standard Cleaning and Packaging (SC-10)* (MS-06-62), page 1174.

Material of Construction

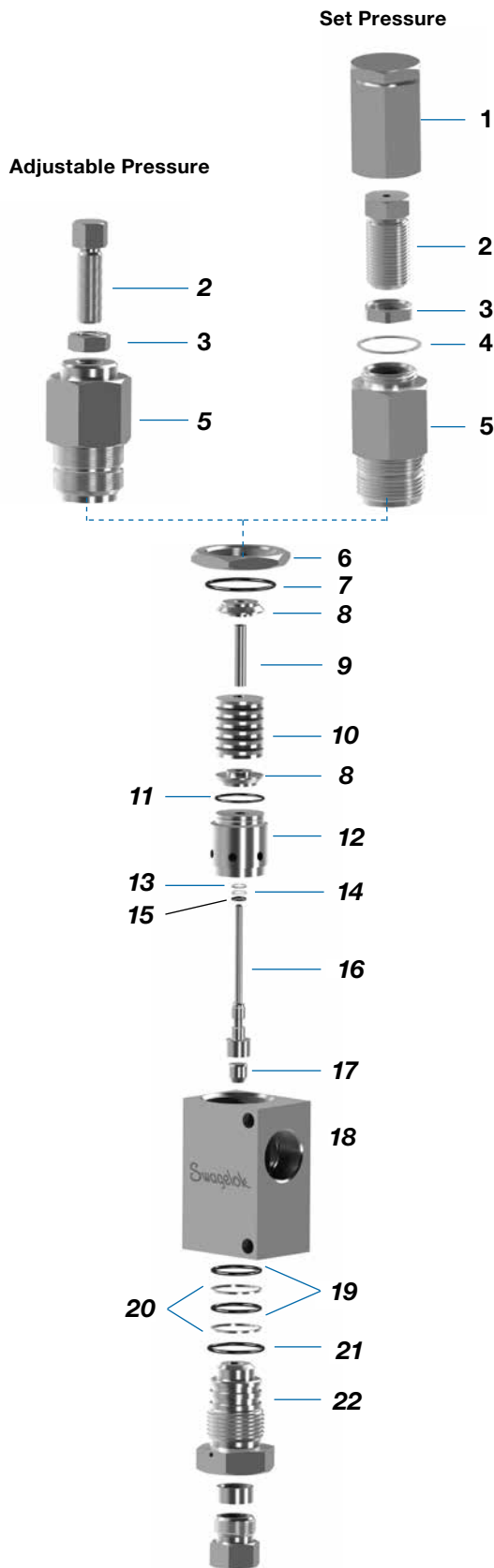

Shown with cone and thread inlet connection

Component	Material Grade/ ASTM Specification
1 Cap	316 SS/A276 or A479
2 Adjusting screw	316 SS/A276 or A479
3 Adjustment lock nut	316 SS/A276 or A479
4 Gasket	316L SS/A276
5 Bonnet	316 SS/A276 or A479
6 Bonnet lock nut	316 SS/A276 or A479
7 O-ring	Fluorocarbon FKM
8 Spring retainer	316 SS/A276 or A479
9 Spring guide	LDPE
10 Spring washer	300 Series SS/A506
11 O-ring	Fluorocarbon FKM
12 Guide	316 SS/A276 or A479
13 Primary stem backup ring	Polyetheretherketone (PEEK)
14 Secondary stem backup ring	Reinforced PTFE
15 O-ring	Fluorocarbon FKM
16 Stem	S17400/A564, Type 630
17 Seat	Reinforced PEEK
18 Body	316 SS/A276 or A479
19 O-ring	Fluorocarbon FKM
20 Backup ring	Reinforced PTFE
21 O-ring	Fluorocarbon FKM
22 Nozzle	316 SS/A276 or A479
Lubricants	Silicone-based with tungsten disulfide additive and hydrocarbon-based

Wetted components listed in *italics*.

Options

O-Ring Materials

Optional O-ring materials are available for IPT series relief valves shown below. To order, add the optional O-ring material designator to the valve ordering number.

Examples:

Optional HNBR O-ring: RVSA6MF12NF1-10-H

Optional perfluorocarbon FFKM O-ring: RVS6MF12NF-C

O-Ring Material	Temperature Rating °F (°C)	Designator
HNBR	0 to 250 (-17 to 121)	-H
Perfluorocarbon FFKM	20 to 185 (-6 to 85)	-C

Maintenance Kits

Seal and Spring Kits

Kit contains seat seal, stem, O-rings, spring, washer and lubricant. Ordering numbers are:

RK-RVS for RVS valve with set pressure

RK-RVAA for RVSA valve with adjustable pressure

Kits are available for legacy relief valves, e.g. RVA9MF12NF10-20 and RV9MF12NF10.2. The kits contain seat seal, stem, O-rings, spring, washer, and lubricant. Ordering numbers are:

RK-RV-MS for RV valve with set pressure

RK-RVA for RVA valve with adjustable pressure

Dimensions and Ordering Information

Dimensions are for reference only and are subject to change.

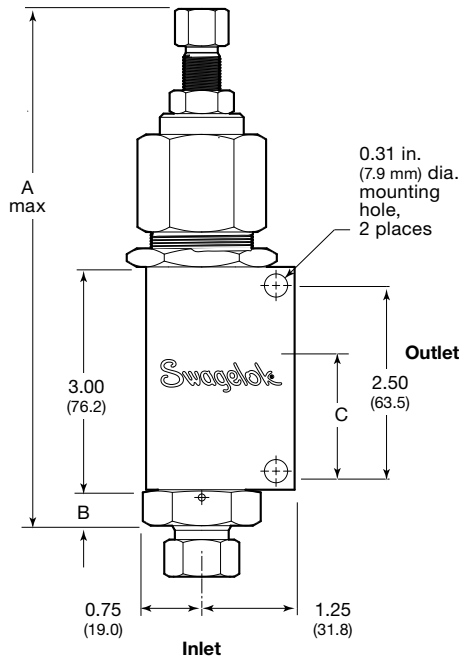

Adjustable Pressure RVA Relief Valve

Valve includes spring washers; set pressure must be adjusted.

Select a valve ordering number.

End Connection		Adjustable Pressure Range psig (bar)	Ordering Number	Dimensions in. (mm)			
Inlet	Outlet			Orifice	A	B	C
3/8 MP cone and thread	3/4 in. female NPT	1 000 to 10 000 (68.9 to 689)	RVSA6MF12NF1-10	0.25 (6.4)	7.05 (179)	0.48 (12.2)	1.75 (44.4)
		10 000 to 20 000 (689 to 1378)	RVSA6MF12NF10-20	0.25 (6.4)	7.05 (179)	0.48 (12.2)	1.75 (44.4)
9/16 MP cone and thread	3/4 in. female NPT	1 000 to 10 000 (68.9 to 689)	RVSA9MF12NF1-10	0.25 (6.4)	7.55 (192)	0.98 (24.9)	1.75 (44.4)
		10 000 to 20 000 (689 to 1378)	RVSA9MF12NF10-20	0.25 (6.4)	7.55 (192)	0.98 (24.9)	1.75 (44.4)

For valves with Swagelok medium-pressure tube fitting connections, contact your authorized Swagelok representative.

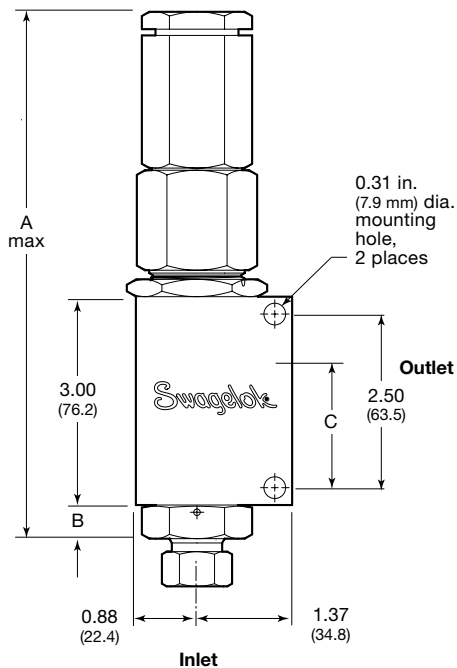

Set Pressure RV Relief Valve

Valve includes spring washers, and is factory-set to the specified set pressure.

To order, add the desired set pressure designator (in *ksi* units) to the basic ordering number as shown below.

End Connection		Basic Ordering Number	Dimensions in. (mm)			
Inlet	Outlet		Orifice	A	B	C
3/8 MP cone and thread	3/4 in. female NPT	RVS6MF12NF_	0.25 (6.4)	8.09 (205)	0.98 (24.9)	1.75 (44.4)
		RVS9MF12NF_	0.25 (6.4)	7.59 (193)	0.48 (12.2)	1.75 (44.4)

Example: RVS6MF12NF2 is a relief valve with a set pressure of 2 *ksi* or 2000 psig (138 bar).

- Set pressures are available from 1000 to 20 000 psig (68.9 to 1378 bar, 1 to 20 *ksi*) in 100 psig (6.9 bar, 0.1 *ksi*) increments
- Set pressures are designated in *ksi* units: 1000 psig = 1 *ksi*, 1500 psig = 1.5 *ksi*, 15 000 psig = 15 *ksi*.

For valves with Swagelok medium-pressure tube fitting connections, contact your authorized Swagelok representative.

Related Products

Tube Fittings

See the Swagelok *Gaugeable Tube Fittings and Adapter Fittings* catalog (MS-01-140), page 2 for more information.



Needle Valves

See the Swagelok *Severe-Service Union-Bonnet Needle Valves—N Series and HN Series* catalog (MS-01-168), page 666 for more information.



Alloy 2507 Tube Fittings

See the Swagelok *Gaugeable Alloy 2507 Super Duplex Tube Fittings* catalog (MS-01-174), page 72 for more information.



Lubricants and Sealants

See the Swagelok *Leak Detectors, Lubricants, and Sealants* catalog (MS-01-91), page 105 for more information.



Pipe Fittings

See the Swagelok *Pipe Fittings* catalog (MS-01-147), page 166 for more information.



Medium- and High-Pressure – Special Alloys

See the Swagelok *Medium- and High-Pressure Fittings and Adapters—Alloy Materials* catalog, MS-02-474, for more information.



Caution: Do not mix or interchange parts with those of other manufacturers.

About this document

Thank you for downloading this electronic catalog, which is part of General Product catalog Swagelok published in print. This type of electronic catalog is updated as new information arises or revisions, which may be more current than the printed version.

Swagelok Company is a major developer and provider of fluid system solutions, including products, integration solutions and services for industry research, instrumentation, pharmaceutical, oil and gas, power, petrochemical, alternative fuels, and semiconductor. Our manufacturing facilities, research, service and distribution facilities support a global network of more than 200 authorized sales and service centers in 57 countries.

Visit www.swagelok.com to locate your Swagelok representative and obtain any information on features, technical information and product references, or to learn about the variety of services available only through authorized sales centers and service Swagelok.

Safe Product Selection

When selecting a product, the total system design must be considered to ensure safe, trouble-free performance. Function, material compatibility, adequate ratings, proper installation, operation, and maintenance are the responsibilities of the system designer and user.

Warranty Information

Swagelok products are backed by The Swagelok Limited Lifetime Warranty. For a copy, visit your Swagelok Web site or contact your authorized Swagelok representative.

Swagelok, Ferrule-Pak, Goop, Hinging-Colleting, IGC, Kenmac, Micro-Fit, Nupro, Snoop, Sno-Trik, SWAK, VCO, VCR, Ultra-Torr, Whitey—TM Swagelok Company
Aflas—TM Asahi Glass Co. Ltd.
AL-6XN—TM Allegheny Ludlum Corporation
AutoCAD—TM Autodesk, Inc.
CSA—TM Canadian Standards Association
DeviceNet—TM ODVA
Kalrez, Krytox—TM DuPont
Elgiloy—TM Elgiloy Specialty Metals
FM—TM FM Global
Grafoil—TM GrafTech International Holdings, Inc.
MAC—TM MAC Valves Inc.
Microsoft, Windows—TM Microsoft Corp.
NACE—TM NACE International
Nitronic—TM AK Steel Corporation
picofast—TM HansTurck KG
Pillar—TM Nippon Pillar Packing Company, Ltd.
Rapid Tap—TM Relton Corporation
15-7 PH, 17-7 PH—TM AK Steel Corp.
Sandvik—TM SandvikAB
Silconert—TM Silcotek Corporation
Simriz—TM Freudenberg-NOK
SolidWorks—TM SolidWorks Corporation