

Tubing Data

Contents

Tubing Selection	224
Tubing Handling	224
Gas Service	225
Tubing Installation	225
Suggested Allowable Working Pressure Tables	
Carbon Steel Tubing	226
Stainless Steel Tubing	227
Copper Tubing	229
Aluminum Tubing	230
Alloy 400 Tubing	231
Alloy C-276 Tubing	232
Alloy 20 Tubing	232
Alloy 600 Tubing	233
Grade 2 Titanium Tubing	233
Alloy 2507 Super Duplex Tubing	234
Alloy 825 Tubing	235
Alloy 625 Tubing	236
Alloy 254 Tubing	237
Elevated Temperature Factors	238

Tubing Selection

Proper selection, handling, and installation of tubing, when combined with proper selection of Swagelok® tube fittings, are essential to reliable tubing systems.

The following variables should be considered when ordering tubing for use with Swagelok tube fittings:

- Surface finish
- Material
- Hardness
- Wall thickness.

Tubing Surface Finish

Many ASTM specifications cover the above requirements, but they often are not very detailed on surface finish. For example, ASTM A450, a general tubing specification, reads:

11. Straightness and Finish
 - 11.1 Finished tubes shall be reasonably straight and have smooth ends free of burrs. They shall have a workmanlike finish. Surface imperfections (Note) may be removed by

grinding, provided that a smooth curved surface is maintained, and the wall thickness is not decreased to less than that permitted by this or the product specification. The outside diameter at the point of grinding may be reduced by the amount so removed.

Note: An imperfection is any discontinuity or irregularity found in the tube.

Tubing Material

Our suggested ordering instructions for each type of tubing are shown under the respective tables.

Tubing Outside Diameter Hardness

The key to selecting proper tubing for use with metal Swagelok tube fittings is that the tubing must be softer than the fitting material. Swagelok tube fittings are designed to work properly with the tubing that is suggested in the ordering instructions.

Swagelok stainless steel tube fittings have been repeatedly tested successfully with tubing with hardness up to 200 HV and 90 HRB.

Tubing Wall Thickness

The accompanying tables show working pressure ratings of tubing in a wide range of wall thicknesses. Except as noted, allowable pressure ratings are calculated from S values as specified by ASME B31.3, Process Piping.

Swagelok tube fittings have been repeatedly tested in both the minimum and maximum wall thicknesses shown.

Swagelok tube fittings are not recommended for tube wall thicknesses outside the ranges shown in the accompanying tables for each size.

Tubing Handling

Good handling practices can greatly reduce scratches on tubing and protect the good surface finish that reliable tube manufacturers supply.

- Tubing should never be dragged out of a tubing rack or across a rough surface.
- Tube cutters or hacksaws should be sharp. Do not take deep cuts with each turn of the cutter or stroke of the saw.
- Tube ends should be deburred. This helps to ensure that the tubing will go all the way through the ferrules without damaging the ferrule sealing edge.

Gas Service

Gases (air, hydrogen, helium, nitrogen, etc.) have very small molecules that can escape through even the most minute leak path. Some surface defects on the tubing can provide such a leak path. As tube outside diameter (OD) increases, so does the likelihood of a scratch or other surface defect interfering with proper sealing.

The most successful connection for gas service will occur if all installation instructions are carefully followed and the heavier wall thicknesses of tubing on the accompanying tables are selected.

A heavy-wall tube resists ferrule action more than a thin-wall tube, allowing the ferrules to coin out minor surface imperfections. A thin-wall tube offers less resistance to ferrule action during installation, reducing the chance of coining out surface defects, such as scratches. Within the applicable suggested allowable working pressure table, select a tube wall thickness whose working pressure is *outside* of the shaded areas.

Tubing Installation

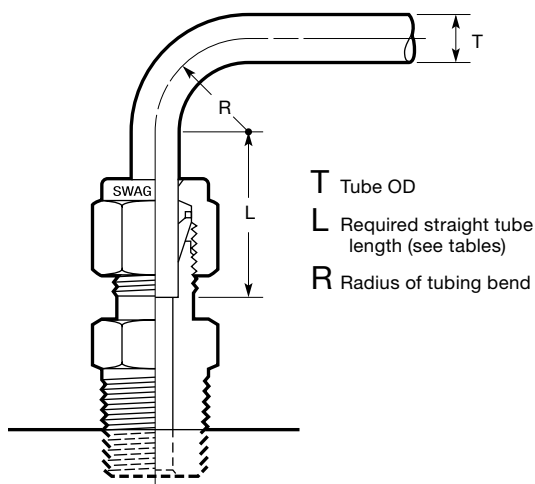

Tubing properly selected and handled, combined with properly installed Swagelok tube fittings, will give you a leak-tight system and provide reliable service in a wide variety of applications.

For maximum assurance of reliable performance, use:

- properly selected and handled high-quality tubing—such as provided by Swagelok
- Swagelok tube fittings assembled in accordance with catalog instructions
- an appropriate tube support system to limit the movement of tubing and fluid system components.

When installing fittings near tube bends, there must be a sufficient straight length of tubing to allow the tube to be bottomed in the Swagelok fitting (see tables).

Fractional, in.	
T Tube OD	L ^①
1/16	1/2
1/8	23/32
3/16	3/4
1/4	13/16
5/16	7/8
3/8	15/16
1/2	1 3/16
5/8	1 1/4
3/4	
7/8	1 5/16
1	1 1/2
1 1/4	2
1 1/2	2 13/32
2	3 1/4

① Required straight tube length.

Metric, mm	
T Tube OD	L ^①
3	19
6	21
8	23
10	25
12	31
14	32
15	
16	
18	34
20	
22	
25	40
28	46
30	50
32	54
38	63
50	80

Hydraulic Swaging Unit

A Swagelok multihead hydraulic swaging unit (MHSU) **must** be used to install 1 1/4, 1 1/2, and 2 in. and 28, 30, 32, 38, and 50 mm Swagelok tube fittings. For more information, see the *Gageable Tube Fittings and Adapter Fittings* catalog (MS-01-140), page 57.

Suggested Allowable Pressure Tables

Figure and tables are for reference only. No implication is made that these values can be used for design work. Applicable codes and practices in industry should be considered. ASME Codes are the successor to and replacement of ASA Piping Codes.

- All pressures are calculated from equations in ASME B31.3, Process Piping. See factors for calculating working pressures in accordance with ASME B31.1, Power Piping.

- Calculations are based on maximum OD and minimum wall thickness, except as noted in individual tables.

Example: 1/2 in. OD × 0.035 in. wall stainless steel tubing purchased to ASTM A269:

OD Tolerance ± 0.005 in. / Wall Thickness ± 10 %

Calculations are based on 0.505 in. OD × 0.0315 in. wall tubing.

- No allowance is made for corrosion or erosion.

Suggested Allowable Working Pressure for Carbon Steel Tubing

Table 1—Fractional Carbon Steel Tubing

Allowable working pressures are calculated from an S value of 15 700 psi (108.2 MPa) for ASTM A179 tubing at –20 to 100°F (–28 to 37°C), as listed in ASME B31.3. For working pressure in accordance with ASME B31.1, multiply by 0.85.

Tube OD in.	Tube Wall Thickness, in.													Swagelok Fitting Series
	0.028	0.035	0.049	0.065	0.083	0.095	0.109	0.120	0.134	0.148	0.165	0.180	0.220	
	Working Pressure, psig Note: For gas service, select a tube wall thickness outside of the shaded area. (See Gas Service , page 225.)													
1/8	8000	10 200												200
3/16	5100	6 600	9600											300
1/4	3700	4 800	7000	9600										400
5/16		3 700	5500	7500										500
3/8		3 100	4500	6200										600
1/2		2 300	3200	4500	5900									810
5/8		1 800	2600	3500	4600	5300								1010
3/4			2100	2900	3700	4300	5100							1210
7/8			1800	2400	3200	3700	4300							1410
1			1500	2100	2700	3200	3700	4100						1610
1 1/4				1600	2100	2500	2900	3200	3600	4000	4600	5000		2000
1 1/2					1800	2000	2400	2600	2900	3300	3700	4100	5100	2400
2						1500	1700	1900	2100	2400	2700	3000	3700	3200

TUBING
DATA

Suggested Ordering Information

High-quality, soft annealed seamless carbon steel hydraulic tubing, ASTM A179 or equivalent. Hardness not to exceed 72 HRB or 130 HV. Tubing to be free of scratches, suitable for bending and flaring.

Table 2—Metric Carbon Steel Tubing

Allowable working pressures are based on equations from ASME B31.3 for DIN 2391 tubing, using a stress value of 113 MPa (16 300 psi) and tensile strength of 340 MPa (49 300 psi).

Tube OD mm	Tube Wall Thickness, mm													Swagelok Fitting Series
	0.8	1.0	1.2	1.5	1.8	2.0	2.2	2.5	2.8	3.0	3.5	4.0	4.5	
	Working Pressure, bar Note: For gas service, select a tube wall thickness outside of the shaded area. (See Gas Service , page 225.)													
3	630	790												3M0
6	290	370	460	590										6M0
8		270	330	430										8M0
10		210	260	330										10M0
12		170	210	270	330	380	420							12M0
14		150	180	230	280	320	350							14M0
15		140	170	210	260	290	330							15M0
16		130	150	200	240	270	300	350						16M0
18			140	170	210	240	270	310						18M0
20			120	160	190	210	240	270	310					20M0
22			110	140	170	190	210	240	280					22M0
25			100	120	150	170	180	210	240	260				25M0
28						150	160	190	210	230	270			28M0
30						140	150	170	200	210	250			30M0
32						130	140	160	180	200	230	270		32M0
38							120	130	150	160	190	230	260	38M0

Suggested Ordering Information

High-quality, soft annealed carbon steel tubing, DIN 2391 or equivalent. Hardness not to exceed 72 HRB or 130 HV. Tubing to be free of scratches, suitable for bending or flaring.

Suggested Allowable Working Pressure for Stainless Steel Tubing

Table 3—Fractional Stainless Steel Seamless Tubing

Allowable working pressures are calculated from an S value of 20 000 psi (137.8 MPa) for ASTM A269 tubing at -20 to 100°F (-28 to 37°C), as listed in ASME B31.3 and ASTM A213 tubing at -20 to 100°F (-28 to 37°C), as listed in ASME B31.1, except as noted.

For Welded Tubing

For welded and drawn tubing, a derating factor must be applied for weld integrity:

- for double-welded tubing, multiply working pressure by 0.85
- for single-welded tubing, multiply working pressure by 0.80.

Tube OD in.	Tube Wall Thickness, in.																Swagelok Fitting Series	
	0.010	0.012	0.014	0.016	0.020	0.028	0.035	0.049	0.065	0.083	0.095	0.109	0.120	0.134	0.156	0.188		
	Working Pressure, psig Note: For gas service, select a tube wall thickness outside of the shaded area. (See Gas Service, page 225.)																	
1/16	5600	6800	8100	9400	12 000													100
1/8						8500	10 900											200
3/16						5400	7 000	10 200										300
1/4						4000	5 100	7 500	10 200 ^①									400
5/16							4 000	5 800	8 000									500
3/8							3 300	4 800	6 500	7500 ^{①②}								600
1/2							2 600	3 700	5 100	6700								810
5/8								2 900	4 000	5200	6000							1010
3/4								2 400	3 300	4200	4900	5800						1210
7/8								2 000	2 800	3600	4200	4800						1410
1									2 400	3100	3600	4200	4700					1610
1 1/4										2400	2800	3300	3600	4100	4900			2000
1 1/2											2300	2700	3000	3400	4000	4900		2400
2												2000	2200	2500	2900	3600		3200

① For higher pressures, see the Swagelok *Medium-Pressure Fittings* catalog, MS-02-335, or the Swagelok *High-Pressure Fittings* catalog, MS-01-34.

② Rating based on repeated pressure testing of the Swagelok tube fitting with a 4:1 design factor based upon hydraulic fluid leakage.

Suggested Ordering Information

High-quality, fully annealed (Type 304, 304/304L, 316, 316/316L, 317, 317/317L, 321, 347) (seamless or welded and drawn) stainless steel hydraulic tubing, ASTM A269 and A213, or equivalent. Hardness not to exceed 90 HRB or 200 HV. Tubing to be free of scratches, suitable for bending and flaring. OD tolerances not to exceed ± 0.003 in. for 1/16 in. OD tubing.

Note: Certain austenitic stainless tubing has an allowable ovality tolerance double the OD tolerance and may not fit into Swagelok precision tube fittings. Dual-certified grades such as 304/304L, 316/316L, and 317/317L meet the minimum chemistry and the mechanical properties of both alloy grades.

TUBING DATA

Suggested Allowable Working Pressure for Stainless Steel Tubing

Table 4—Metric Stainless Steel Seamless Tubing

Allowable working pressures are calculated from an S value of 137.8 MPa (20 000 psi) for EN ISO 1127 tubing (D4, T4 tolerance for 3 to 12 mm; D4, T3 tolerance 14 to 50 mm), at –28 to 37°C (–20 to 100°F), as listed in ASME B31.3 and ASTM A213 tubing at –28 to 37°C (–20 to 100°F), as listed in ASME B31.1, except as noted.

For Welded Tubing

For welded and drawn tubing, a derating factor must be applied for weld integrity:

- for double-welded tubing, multiply working pressure by 0.85
- for single-welded tubing, multiply working pressure by 0.80.

Tube OD mm	Tube Wall Thickness, mm														Swagelok Fitting Series	
	0.8	1.0	1.2	1.5	1.8	2.0	2.2	2.5	2.8	3.0	3.5	4.0	4.5	5.0		
	Working Pressure, bar Note: For gas service, select a tube wall thickness outside of the shaded area. (See Gas Service , page 225.)															
3	670															3M0
6	310	420	540	710												6M0
8		310	390	520												8M0
10		240	300	400	510	580										10M0
12		200	250	330	410	470										12M0
14		160	200	270	340	380	430									14M0
15		150	190	250	310	360	400									15M0
16			170	230	290	330	370	400 ^①								16M0
18			150	200	260	290	320	370								18M0
20			140	180	230	260	290	330	380							20M0
22			140	160	200	230	260	300	340							22M0
25					180	200	230	260	290	320						25M0
28						180	200	230	260	280	330					28M0
30						170	180	210	240	260	310					30M0
32						160	170	200	220	240	290	330				32M0
38							140	160	190	200	240	270	310			38M0
50										150	180	210	240	270		50M0

^① Rating based on repeated pressure testing of the Swagelok tube fitting with a 4:1 design factor based upon hydraulic fluid leakage.

Suggested Ordering Information

High-quality, fully annealed (Type 304, 304/304L, 316, 316/316L, 317, 317/317L, 321, 347) stainless steel tubing, EN ISO 1127 or equivalent. Hardness not to exceed 90 HRB or 200 HV. Tubing to be free of scratches, suitable for bending or flaring. OD tolerances not to exceed ± 0.076 mm for 3 mm OD tubing.

Note: Dual-certified grades such as 304/304L, 316/316L, and 317/317L meet the minimum chemistry and the mechanical properties of both alloy grades.

Suggested Allowable Working Pressure for Copper Tubing

Table 5—Fractional Copper Tubing

Allowable working pressures are calculated from an S value of 6000 psi (41.3 MPa) for ASTM B75 and ASTM B88 tubing at -20 to 100°F (-28 to 37°C), as listed in ASME B31.3 and ASME B31.1.

Tube OD in.	Tube Wall Thickness, in.										Swagelok Fitting Series
	0.028	0.030	0.035	0.049	0.065	0.083	0.095	0.109	0.120	0.134	
	Working Pressure, psig Note: For gas service, select a tube wall thickness outside of the shaded area. (See Gas Service , page 225.)										
1/8	2700	3000	3600								200
3/16	1800	1900	2300	3400							300
1/4	1300	1400	1600	2500	3500						400
5/16			1300	1900	2700						500
3/8			1000	1600	2200						600
1/2			800	1100	1600	2100					810
5/8				900	1200	1600	1900				1010
3/4				700	1000	1300	1500	1800			1210
7/8				600	800	1100	1300	1500			1410
1				500	700	900	1100	1300	1500		1610
1 1/8					600	800	1000	1100	1300	1400	1810

Suggested Ordering Information

High-quality, soft annealed seamless copper tubing, ASTM B75 or equivalent. Also soft annealed (Temper O) copper water tube, type K or type L to ASTM B88.

Table 6—Metric Copper Tubing

Allowable working pressures are calculated from an S value of 41.3 MPa (6000 psi) for ASTM B75, ASTM B88, and EN 1057 tubing at -28 to 37°C (-20 to 100°F), as listed in ASME B31.3 and ASME B31.1.

Tube OD mm	Tube Wall Thickness, mm										Swagelok Fitting Series
	0.8	1.0	1.2	1.5	1.8	2.0	2.2	2.5	2.8	3.0	
	Working Pressure, bar Note: For gas service, select a tube wall thickness outside of the shaded area. (See Gas Service , page 225.)										
6	110	140	170	220							6M0
8		100	120	160							8M0
10		80	100	130							10M0
12		60	80	100	130	140					12M0
14		50	60	90	110	120					14M0
15			60	80	100	110	120				15M0
16				70	90	100	110	120			16M0
18				60	80	90	100	110			18M0
20				60	70	80	90	100	110		20M0
22				50	60	70	80	90	100		22M0
25				40	50	60	70	80	90	100	25M0
28					40	50	60	70	80	90	28M0

Suggested Ordering Information

High-quality, soft annealed seamless copper tubing, ASTM B75 and EN 1057 or equivalent. Also soft annealed (Temper O) copper water tube, type K or type L to ASTM B88.

Suggested Allowable Working Pressure for Aluminum Tubing

Table 7—Fractional Aluminum Tubing

Allowable working pressures are calculated from an S value of 14 000 psi (96.5 MPa) for ASTM B210, Type 6061-T6 tubing at –20 to 100°F (–28 to 37°C), as listed in ASME B31.3. For working pressure in accordance with ASME B31.1, multiply by 0.85.

Tube OD in.	Tube Wall Thickness, in.					Swagelok Fitting Series
	0.035	0.049	0.065	0.083	0.095	
	Working Pressure, psig Note: For gas service, select a tube wall thickness outside of the shaded area. (See Gas Service , page 225.)					
1/8	8600					200
3/16	5600	8000				300
1/4	4000	5900				400
5/16	3100	4600				500
3/8	2600	3700				600
1/2	1900	2700	3700			810
5/8	1500	2100	2900			1010
3/4		1700	2400	3100		1210
1		1300	1700	2300	2700	1610

TUBING
DATA

Suggested Ordering Information

High-quality aluminum alloy drawn seamless tubing, ASTM B210 (Type 6061-T6) or equivalent.

Table 8—Metric Aluminum Tubing

Allowable working pressures are calculated from an S value of 96.5 MPa (14 000 psi) for ASTM B210, Type 6061-T6 tubing at –28 to 37°C (–20 to 100°F), as listed in ASME B31.3. For working pressure in accordance with ASME B31.1, multiply by 0.85.

Tube OD mm	Tube Wall Thickness, mm							Swagelok Fitting Series
	1.0	1.2	1.5	1.8	2.0	2.2	2.5	
	Working Pressure, bar Note: For gas service, select a tube wall thickness outside of the shaded area. (See Gas Service , page 225.)							
6	340	400						6M0
8	240	300						8M0
10	190	230						10M0
12	160	190	240	250				12M0
14	130	160	200	220				14M0
15	120	150	190	200				15M0
16	110	140	170	190				16M0
18		120	150	190	210			18M0
25			110	130	150	170	180	25M0

Suggested Ordering Information

High-quality aluminum alloy drawn seamless tubing, ASTM B210 (Type 6061-T6) or equivalent.

Suggested Allowable Working Pressure for Additional Alloys

A limited amount of test data is available on Swagelok tube fittings used with special alloy tubing. For sizes not listed in the following tables, we recommend that a sample of the tubing be provided for evaluation before installation. Please include all pertinent information relating to system parameters. Give tubing sample to your authorized Swagelok representative to forward to the factory.

Table 9—Fractional Alloy 400 Tubing

Allowable working pressures are calculated from an S value of 18 700 psi (128.9 MPa) for ASTM B165 tubing at -20 to 100°F (-28 to 37°C), as listed in ASME B31.3 and ASME B31.1.

Tube OD in.	Tube Wall Thickness, in.								Swagelok Fitting Series
	0.028	0.035	0.049	0.065	0.083	0.095	0.109	0.120	
	Working Pressure, psig Note: For gas service, select a tube wall thickness outside of the shaded area. (See Gas Service , page 225.)								
1/8	7900	10 100							200
1/4	3700	4 800	7000	9500					400
5/16		3 700	5400	7300					500
3/8		3 100	4400	6100					600
1/2		2 300	3200	4400					810
3/4			2200	3000	4000	4600			1210
1				2200	2900	3400	3900	4300	1610

Suggested Ordering Information

High-quality, fully annealed seamless alloy 400 hydraulic tubing, ASTM B165 or equivalent. Hardness not to exceed 75 HRB or 137 HV. Tubing to be free of scratches, suitable for bending and flaring. OD tolerances not to exceed ± 0.005 in.

Table 10—Metric Alloy 400 Tubing

Allowable working pressures are calculated from an S value of 128.9 MPa (18 700 psi) for ASTM B165 tubing at -28 to 37°C (-20 to 100°F), as listed in ASME B31.3 and ASME B31.1.

Tube OD mm	Tube Wall Thickness, mm										Swagelok Fitting Series
	0.8	1.0	1.2	1.5	1.8	2.0	2.2	2.5	2.8	3.0	
	Working Pressure, bar Note: For gas service, select a tube wall thickness outside of the shaded area. (See Gas Service , page 225.)										
6	310	390	490	620							6M0
8		290	350	450							8M0
10		220	280	350							10M0
12		180	230	290							12M0
14		160	190	240	270						14M0
18			150	200	240	270	300				18M0
20				180	210	240	270	290			20M0
25					170	190	210	240	270	290	25M0

Suggested Ordering Information

High-quality, fully annealed seamless alloy 400 hydraulic tubing, ASTM B165 or equivalent. Hardness not to exceed 75 HRB or 137 HV. Tubing to be free of scratches, suitable for bending and flaring. OD tolerances not to exceed ± 0.13 mm.

TUBING DATA

Suggested Allowable Working Pressure for *Additional Alloys*

Table 11—Fractional Alloy C-276 Tubing

Allowable working pressures are based on equations from ASME B31.3 and ASME B31.1 for a maximum S value of 20 000 psi (137.8 MPa).

Tube OD in.	Tube Wall Thickness, in.				Swagelok Fitting Series
	0.028	0.035	0.049	0.065	
	Working Pressure, psig Note: For gas service, select a tube wall thickness outside of the shaded area. (See Gas Service , page 225.)				
1/4	4000	5100	7500	10 200	400
5/16		4000	5800	7 800	500
3/8		3300	4800	6 500	600
1/2		2600	3700	5 100	810

Suggested Ordering Information

High-quality, fully annealed alloy C-276 tubing, ASTM B622 or equivalent. Hardness not to exceed 100 HRB or 248 HV. Tubing to be free of scratches, suitable for bending and flaring. OD tolerances not to exceed ± 0.005 in.

Table 12—Metric Alloy C-276 Tubing

Allowable working pressures are based on equations from ASME B31.3 and ASME B31.1 for a maximum S value of 137.8 MPa (20 000 psi).

Tube OD mm	Tube Wall Thickness, mm				Swagelok Fitting Series
	0.8	1.0	1.2	1.5	
	Working Pressure, bar Note: For gas service, select a tube wall thickness outside of the shaded area. (See Gas Service , page 225.)				
6	310	420	520	670	6M0
8		310	390	500	8M0
10		240	300	380	10M0
12		200	240	310	12M0

Suggested Ordering Information

High-quality, fully annealed alloy C-276 tubing, ASTM B622 or equivalent. Hardness not to exceed 100 HRB or 248 HV. Tubing to be free of scratches, suitable for bending and flaring. OD tolerances not to exceed ± 0.13 mm.

Table 13—Fractional Alloy 20 Tubing

Allowable working pressures are based on equations from ASME B31.3 and ASME B31.1 for a maximum S value of 20 000 psi (137.8 MPa).

Tube OD in.	Tube Wall Thickness, in.				Swagelok Fitting Series
	0.028	0.035	0.049	0.065	
	Working Pressure, psig Note: For gas service, select a tube wall thickness outside of the shaded area. (See Gas Service , page 225.)				
1/4	4000	5100	7500	10 200	400
3/8		3300	4800	6 500	600
1/2		2600	3700	5 100	810

Suggested Ordering Information

High-quality, fully annealed seamless or welded and drawn alloy 20 tubing, ASTM B729, B468 or equivalent. Hardness not to exceed 95 HRB. Tubing to be free of scratches, suitable for bending and flaring. OD tolerances not to exceed ± 0.005 in.

Table 14—Metric Alloy 20 Tubing

Allowable working pressures are based on equations from ASME B31.3 and ASME B31.1 for a maximum S value of 137.8 MPa (20 000 psi).

Tube OD mm	Tube Wall Thickness, mm				Swagelok Fitting Series
	0.8	1.0	1.2	1.5	
	Working Pressure, bar Note: For gas service, select a tube wall thickness outside of the shaded area. (See Gas Service , page 225.)				
6	310	420	520	670	6M0
10		240	300	380	10M0
12		200	240	310	12M0

Suggested Ordering Information

High-quality, fully annealed seamless or welded and drawn alloy 20 tubing, ASTM B729, B468 or equivalent. Hardness not to exceed 95 HRB. Tubing to be free of scratches, suitable for bending and flaring. OD tolerances not to exceed ± 0.13 mm.

Suggested Allowable Working Pressure for Additional Alloys

Table 15—Fractional Alloy 600 Tubing

Allowable working pressures are based on equations from ASME B31.3 and ASME B31.1 for a maximum S value of 20 000 psi (137.8 MPa).

Tube OD in.	Tube Wall Thickness, in.				Swagelok Fitting Series
	0.028	0.035	0.049	0.065	
	Working Pressure, psig Note: For gas service, select a tube wall thickness outside of the shaded area. (See Gas Service , page 225.)				
1/4	4000	5100	7500	10 200	400
3/8		3300	4800	6 500	600
1/2		2600	3700	5 100	810

Suggested Ordering Information

High-quality, fully annealed, cold drawn #1 temper alloy 600 seamless alloy tubing, ASTM B167 or equivalent. Hardness not to exceed 92 HRB or 198 HV. Tubing to be free of scratches, suitable for bending and flaring. Order to outside diameter and wall thickness only, not to inside diameter, average wall specification. OD tolerances not to exceed ± 0.005 in.

Table 16—Metric Alloy 600 Tubing

Allowable working pressures are based on equations from ASME B31.3 and ASME B31.1 for a maximum S value of 137.8 MPa (20 000 psi).

Tube OD mm	Tube Wall Thickness, mm				Swagelok Fitting Series
	0.8	1.0	1.2	1.5	
	Working Pressure, bar Note: For gas service, select a tube wall thickness outside of the shaded area. (See Gas Service , page 225.)				
6	310	420	520	670	6M0
10		240	300	380	10M0
12		200	240	310	12M0

Suggested Ordering Information

High-quality, fully annealed, cold drawn #1 temper alloy 600 seamless alloy tubing, ASTM B167 or equivalent. Hardness not to exceed 92 HRB or 198 HV. Tubing to be free of scratches, suitable for bending and flaring. Order to outside diameter and wall thickness only, not to inside diameter, average wall specification. OD tolerances not to exceed ± 0.13 mm.

Table 17—Fractional Grade 2 Titanium Tubing

Allowable working pressures are based on equations from ASME B31.3 and a maximum S value of 16 700 psi (115.1 MPa) for ASTM B338 tubing at –20 to 100°F (–28 to 37°C). For working pressure in accordance with ASME B31.1, multiply by 0.85.

Tube OD in.	Tube Wall Thickness, in.				Swagelok Fitting Series
	0.028	0.035	0.049	0.065	
	Working Pressure, psig Note: For gas service, select a tube wall thickness outside of the shaded area. (See Gas Service , page 225.)				
1/4	3500	4500	6700	9100	400
3/8		2900	4200	5800	600
1/2		2100	3100	4200	810

Suggested Ordering Information

High-quality, fully annealed seamless or welded and drawn grade 2 titanium tubing, ASTM B338 or equivalent. Tubing to be free of scratches, suitable for bending. OD tolerances not to exceed ± 0.005 in.

Table 18—Metric Grade 2 Titanium Tubing

Allowable working pressures are based on equations from ASME B31.3 and a maximum S value of 115.1 MPa (16 700 psi) for ASTM B338 tubing at –28 to 37°C (–20 to 100°F). For working pressure in accordance with ASME B31.1, multiply by 0.85.

Tube OD mm	Tube Wall Thickness, mm				Swagelok Fitting Series
	0.8	1.0	1.2	1.5	
	Working Pressure, bar Note: For gas service, select a tube wall thickness outside of the shaded area. (See Gas Service , page 225.)				
6	290	380	470	600	6M0
10		210	260	340	10M0
12		180	220	280	12M0

Suggested Ordering Information

High-quality, fully annealed seamless or welded and drawn grade 2 titanium tubing, ASTM B338 or equivalent. Tubing to be free of scratches, suitable for bending. OD tolerances not to exceed ± 0.13 mm.

TUBING DATA

Suggested Allowable Working Pressure for *Additional Alloys*

Table 19—Fractional Alloy 2507 Super Duplex Tubing

Allowable working pressures are calculated from an S value of 38 700 psi (266.8 MPa) for ASTM A789 tubing at –20 to 100°F (–28 to 37°C), as listed in ASME B31.3. For tubing suitable for Alloy 2507 super duplex weld fittings with working pressures calculated based on ASME B31.3 Chapter IX, see the Swagelok *Alloy 2507 Super Duplex Weld Fittings* catalog (MS-01-173), page 128. For tubing use at temperatures below –20°F (–28°C), see the Swagelok *Alloy 2507 Super Duplex Tube Fittings* catalog (MS-01-174), page 72.

Tube OD in.	Tube Wall Thickness, in.					Swagelok Fitting Series
	0.035	0.049	0.065	0.083	0.095	
	Working Pressure, psig Note: For gas service, select a tube wall thickness outside of the shaded area. (See Gas Service , page 225.)					
1/4	10 000	15 000 ^①				400
3/8	6 500	10 100 ^①	12 700			600
1/2	5 000	7 200	10 100 ^①	12 900		810
5/8		5 800	7 600	10 100		1010
3/4		4 700	6 300	8 500 ^①	10 000 ^①	1210

^① Pressure ratings based on special wall thickness tolerance for Swagelok Alloy 2507 tubing.

Suggested Ordering Information

High-quality, fully annealed Alloy 2507 super duplex tubing, ASTM A789 or equivalent. Hardness not to exceed 32 HRC. Tubing to be free of scratches, suitable for bending and flaring.

Suggested Allowable Working Pressure for Additional Alloys

Table 20—Fractional Alloy 825 Tubing

Allowable working pressures are calculated from an S value of 23 300 psi (160.6 MPa) for ASTM B163 and ASTM B423 seamless tubing at -20 to 100°F (-28 to 37°C), as listed in ASME BPV 2007 Section II, Part D or ASME B31.3. For ASTM B704, Class 1 or equivalent welded and drawn tubing, multiply working pressure by 0.85.

Tube OD in.	Tube Wall Thickness, in.					Swagelok Fitting Series
	0.035	0.049	0.065	0.083	0.095	
	Working Pressure, psig Note: For gas service, select a tube wall thickness outside of the shaded area. (See Gas Service , page 225.)					
1/4	6400	9300	11 600 ^①			400
3/8	4100	5900	8 200			600
1/2	3000	4300	5 900			800
3/4			3 800	4900	5800	1210
1			2 800	3600	4200	1610

^① Based on repeated pressure testing of the Swagelok tube fitting with 4:1 design factor based upon hydraulic fluid leakage.

Suggested Ordering Information

High-quality, fully annealed seamless alloy 825 tubing, ASTM B163, ASTM B423, or equivalent. Fully annealed welded alloy 825 tubing, ASTM B704, class 1 or equivalent. Hardness not to exceed HR_{15T}90 or 201 HV. Tubing to be free of scratches, suitable for bending and flaring. Wall thickness tolerances not to exceed ± 10 %.

Table 21—Metric Alloy 825 Tubing

Allowable working pressures are calculated from an S value of 160.6 MPa (23 300 psi) for ASTM B163 and ASTM B423 seamless tubing at -28 to 37°C (-20 to 100°F), as listed in ASME BPV 2007 Section II, Part D or ASME B31.3. For ASTM B704, Class 1 or equivalent welded and drawn tubing, multiply working pressure by 0.85.

Tube OD mm	Tube Wall Thickness, mm								Swagelok Fitting Series
	0.8	1.0	1.2	1.5	1.8	2.0	2.2	2.5	
	Working Pressure, bar								
6	410	530	660						6M0
10		300	370	480					10M0
12		250	300	390	480				12M0
18				240	300	340	380	400 ^①	18M0
25						240	260	300	25M0

^① Based on repeated pressure testing of the Swagelok tube fitting with 4:1 design factor based upon hydraulic fluid leakage.

Suggested Ordering Information

High-quality, fully annealed seamless alloy 825 tubing, ASTM B163, ASTM B423, or equivalent. Fully annealed welded alloy 825 tubing, ASTM B704, class 1 or equivalent. Hardness not to exceed HR_{15T}90 or 201 HV. Tubing to be free of scratches, suitable for bending and flaring. Wall thickness tolerances not to exceed ± 10 %.

Suggested Allowable Working Pressure for *Additional Alloys*

Table 22—Fractional Alloy 625 Tubing

Allowable working pressures are calculated from an S value of 26 700 psi (184.1 MPa) for ASTM B444 Grade 2 tubing at –20 to 100°F (–28 to 37°C), as listed in ASME BPV 2007 Section II, Part D, Table 1B; tubing outside diameter and wall thickness tolerances from ASTM B444 for small-diameter tube.

Tube OD in.	Tube Wall Thickness, in.			Swagelok Fitting Series
	0.035	0.049	0.065	
	Working Pressure, psig			
1/4	7300	10 700	14 600	400
3/8	4700	6 800	9 400	600
1/2	3500	5 000	6 800	800

Suggested Ordering Information

High-quality, fully annealed seamless alloy 625 tubing, ASTM B444, Grade 1 or 2, or equivalent. Hardness not to exceed 25 HRC or 266 HV. Tubing to be free of scratches, suitable for bending and flaring.

Table 23—Metric Alloy 625 Tubing

Allowable working pressures are calculated from an S value of 184.1 MPa (26 700 psi) for ASTM B444 Grade 2 tubing at –28 to 37°C (–20 to 100°F), as listed in ASME BPV 2007 Section II, Part D, Table 1B; tubing outside diameter and wall thickness tolerances from ASTM B444 for small-diameter tube.

Tube OD mm	Tube Wall Thickness, mm					Swagelok Fitting Series
	0.8	1.0	1.2	1.5	1.8	
	Working Pressure, bar					
6	470	610	750			6M0
10		350	430	550		10M0
12		290	350	450	550	12M0

Suggested Ordering Information

High-quality, fully annealed seamless alloy 625 tubing, ASTM B444, Grade 1 or 2, or equivalent. Hardness not to exceed 25 HRC or 266 HV. Tubing to be free of scratches, suitable for bending and flaring.

Suggested Allowable Working Pressure for Additional Alloys

Table 24—Fractional Alloy 254 Tubing

Allowable working pressures are calculated from an S value of 27 100 psig (186.8 MPa) for ASTM A213 tubing at –20 to 100°F (–28 to 37°C), as listed in ASME B31.3 and ASME B31.1, except as noted.

For Welded Tubing

For welded and drawn tubing, a derating factor must be applied for weld integrity:

- for double-welded tubing, multiply working pressure by 0.85
- for single-welded tubing, multiply working pressure by 0.80.

Tube OD in.	Tube Wall Thickness, in.					Swagelok Fitting Series
	0.028	0.035	0.049	0.065	0.083	
	Working Pressure, psig Note: For gas service, select a tube wall thickness outside of the shaded area. (See Gas Service , page 225.)					
1/4	5400	6900	10 100	13 900		400
3/8		4500	6 500	8 900		600
1/2		3500	5 000	6 900	9000	800

Suggested Ordering Information

High-quality, fully annealed seamless or welded and drawn alloy 254 hydraulic tubing, ASTM A269 or ASTM A213, or equivalent. Hardness not to exceed 96 HRB. Tubing to be free of scratches, suitable for bending and flaring.

Table 25—Metric Alloy 254 Tubing

Allowable working pressures are calculated from an S value of 186.8 MPa (27 100 psig) for ASTM A213 tubing at –20 to 100°F (–28 to 37°C), as listed in ASME B31.3 and ASME B31.1, except as noted.

For Welded Tubing

For welded and drawn tubing, a derating factor must be applied for weld integrity:

- for double-welded tubing, multiply working pressure by 0.85
- for single-welded tubing, multiply working pressure by 0.80.

Tube OD mm	Tube Wall Thickness, mm						Swagelok Fitting Series
	0.8	1.0	1.2	1.5	1.8	2.0	
	Working Pressure, bar						
6	430	580	740	980			6M0
8		420	530	710			8M0
10		330	420	550	700	790	10M0
12		270	340	450	570	650	12M0

Suggested Ordering Information

High-quality, fully annealed seamless or welded and drawn alloy 254 hydraulic tubing, ASTM A269 or ASTM A213, or equivalent. Hardness not to exceed 96 HRB. Tubing to be free of scratches, suitable for bending and flaring.

Pressure Ratings at Elevated Temperatures

Table 26—Elevated Temperature Factors

Temperature		Tubing Materials							
°F	°C	Aluminum	Copper	Carbon Steel ^①	304, 304/304L ^②	316, 316/316L ^②	317, 317/317L ^②	321 ^③	347 ^③
200	93	1.00	0.80	0.95	1.00	1.00	1.00	1.00	1.00
400	204	0.40	0.50	0.87 ^①	0.93	0.96	0.96	0.96	0.96
600	315				0.82	0.85	0.85	0.85	0.85
800	426				0.76	0.79	0.79	0.79	0.79
1000	537				0.69	0.76	0.76	0.76	0.76

Temperature		Tubing Materials								
°F	°C	Alloy 400	Alloy 20 ^③	Alloy C-276 ^③	Alloy 600 ^③	Ti	Alloy 2507	Alloy 825	Alloy 625	Alloy 254
200	93	0.87	1.00	1.00	1.00	0.86	0.90	1.00	0.93	0.90
400	204	0.79	0.96	0.96	0.96	0.61	0.82 ^④	0.90	0.85	0.74
600	315	0.79	0.85	0.85	0.85	0.45		0.84	0.79	0.67
800	426	0.75	0.79	0.79	0.79			0.81	0.75	
1000	537			0.76	0.35				0.73	

① Based on 375°F (190°C) max.

② Dual-certified grades such as 304/304L, 316/316L, and 317/317L meet the requirements for the lower maximum carbon content of the L grades and the higher minimum yield and tensile strength of the non-L grades.

③ Based on the lower derating factor for stainless steel, in accordance with ASME B31.3.

④ Use of 2507 super duplex stainless steel at temperatures above 482°F (250°C) causes microstructural changes that lead to embrittlement and loss of corrosion resistance. Derating factor at 482°F (250°C) is 0.81.

To determine allowable working pressure at elevated temperatures, multiply allowable working pressures from Tables 1 through 25 by a factor shown in Table 26.

Example: Type 316 stainless steel 1/2 in. OD × 0.035 in. wall at 1000°F

1. The allowable working pressure at -20 to 100°F (-28 to 37°C) is 2600 psig (Table 3, page 227).

2. The elevated temperature factor for 1000°F (537°C) is 0.76 (Table 26, above):

$$2600 \text{ psig} \times 0.76 = 1976 \text{ psig}$$

The allowable working pressure for 316 SS 1/2 in. OD × 0.035 in. wall tubing at 1000°F (537°C) is 1976 psig.

About this document

Thank you for downloading this electronic catalog, which is part of General Product catalog Swagelok published in print. This type of electronic catalog is updated as new information arises or revisions, which may be more current than the printed version.

Swagelok Company is a major developer and provider of fluid system solutions, including products, integration solutions and services for industry research, instrumentation, pharmaceutical, oil and gas, power, petrochemical, alternative fuels, and semiconductor. Our manufacturing facilities, research, service and distribution facilities support a global network of more than 200 authorized sales and service centers in 57 countries.

Visit www.swagelok.com to locate your Swagelok representative and obtain any information on features, technical information and product references, or to learn about the variety of services available only through authorized sales centers and service Swagelok.

Safe Product Selection

When selecting a product, the total system design must be considered to ensure safe, trouble-free performance. Function, material compatibility, adequate ratings, proper installation, operation, and maintenance are the responsibilities of the system designer and user.

Warranty Information

Swagelok products are backed by The Swagelok Limited Lifetime Warranty. For a copy, visit your Swagelok Web site or contact your authorized Swagelok representative.

Swagelok, Ferrule-Pak, Goop, Hinging-Colleting, IGC, Kenmac, Micro-Fit, Nupro, Snoop, Sno-Trik, SWAK, VCO, VCR, Ultra-Torr, Whitey—TM Swagelok Company
Atlas—TM Asahi Glass Co. Ltd.
AL-6XN—TM Allegheny Ludlum Corporation
AutoCAD—TM Autodesk, Inc.
CSA—TM Canadian Standards Association
DeviceNet—TM ODVA
Kalrez, Krytox—TM DuPont
Elgiloy—TM Elgiloy Specialty Metals
FM—TM FM Global
Grafoil—TM GrafTech International Holdings, Inc.
MAC—TM MAC Valves Inc.
Microsoft, Windows—TM Microsoft Corp.
NACE—TM NACE International
picofast—TM HansTurck KG
Pillar—TM Nippon Pillar Packing Company, Ltd.
15-7 PH, 17-7 PH—TM AK Steel Corp.
Sandvik—TM SandvikAB
Silconert—TM Silcotek Corporation
Simriz—TM Freudenberg-NOK
SolidWorks—TM SolidWorks Corporation