



Gas Distribution Program

Improving Safety and Performance of Gas Systems

Backed by 70-plus years of fluid system expertise and a global network of pressure control advisors, Swagelok® is uniquely positioned to provide gas distribution systems and pressure control advisory services that help you ensure your facilities and sites are operating safely and efficiently.

Ensure safety

Designed to reduce the potential for gas leaks and maximize operator safety, Swagelok gas distribution systems are fully assembled and tested by certified fluid system experts. Systems are designed and labeled to be both easy to understand and safe to use.

Improve uptime and reliability

The design and quality of Swagelok gas distribution systems help ensure the reliability and uptime of your instruments. These systems allow ease of maintenance and troubleshooting to keep systems reliably delivering the pressure and flow required for each application.

Reduce cost

Swagelok gas distribution systems help maximize efficiency of gas usage and minimize costly leakage. Assembled prior to delivery with leak-tight Swagelok components and tested, these systems are constructed to provide long-lasting performance while helping you reduce operating costs.

Save time and resources

Certified pressure control experts at Swagelok design, assemble, and test gas distribution systems prior to delivery, limiting the need for you to build systems on site and allowing your specialists to focus their efforts elsewhere. The reliability of these systems can also lead to a reduced need for maintenance, saving you additional time and resources.

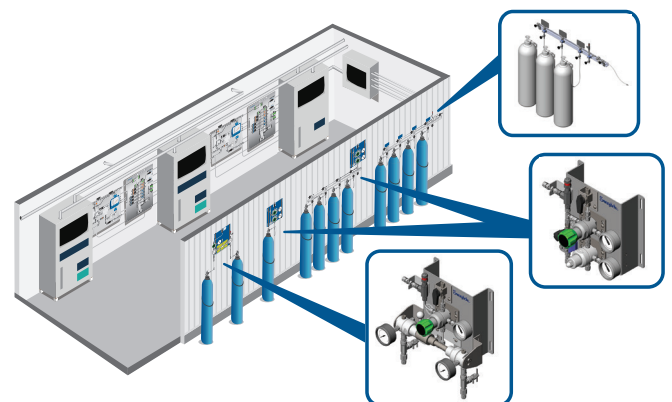

Configurable. Local. Reliable.



Swagelok gas distribution systems are:

- Designed with safety in mind to reduce the potential for gas leaks
- Intended to help maximize gas usage
- Fully assembled and tested prior to delivery to ensure reliable performance
- Easy to maintain and troubleshoot
- Assembled using high-quality, standard Swagelok components to provide reliability and reduce lead times for replacements
- Designed and labeled for standardization to reduce training and make operation safe and easy to understand
- Covered by the Swagelok Limited Lifetime Warranty

Swagelok pressure control service

Our certified pressure control advisors will evaluate your existing gas distribution systems and make recommendations for improvements. We can also help you make the proper pressure regulator selection for existing or future applications. Our fluid system experts can also design and assemble a gas distribution system that meets your site specifications, taking the workload off of your team.

Standard gas distribution assemblies

Swagelok® source inlet (SSI)

Establishes a connection between the high-pressure gas source and the rest of the gas distribution system.

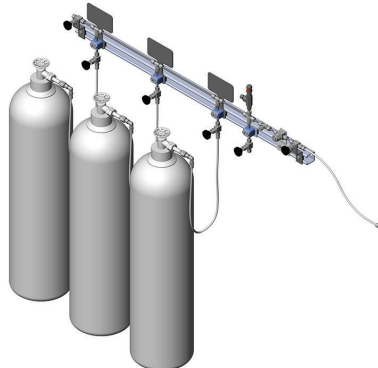

Swagelok® gas panel (SGP)

Completes the first pressure reduction of the source gas to ensure the gas is delivered at the correct pressure within the system-required flow rates to the next stage of the system.

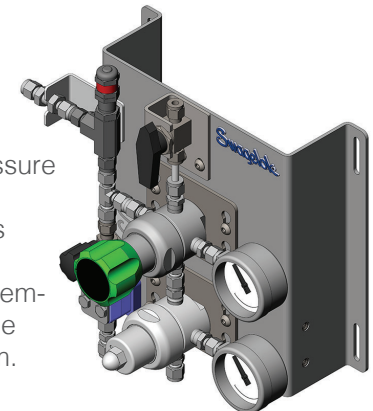

Swagelok® changeover (SCO)

Seamlessly switches from one gas source to another to ensure an uninterrupted supply of gas.

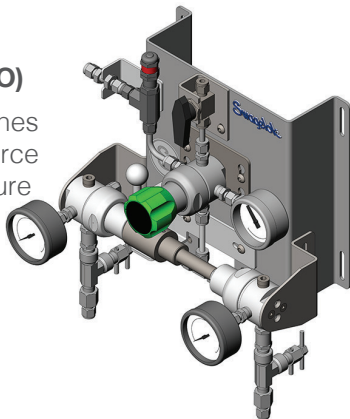

Swagelok® point-of-use (SPU)

Provides the critical last stage of pressure control prior to the gas being used.

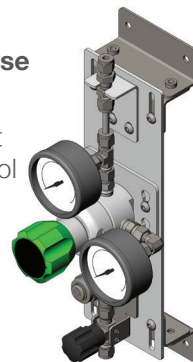

Contact Swagelok Southern Africa to schedule an evaluation of center to schedule an evaluation of your current

SWAGelok SUB-SAHARAN AFRICA

Unit 1, Westlake Park, 38 Avalon Road, Westlake, Modderfontein Gauteng, South Africa
011 609 7925 or 08600 (SWAGELOK)79243 | ssa@swagelok.com | www.swagelok.com

All service marks and trademarks shown are owned and registered by Swagelok Company unless otherwise noted.
© 2020 Swagelok Southern Africa, © 2020 Swagelok Company. swagelok.com CORP-0184-5, Rev-, November 2020

Swagelok

Swagelok Sub-Saharan Africa