

Swagelok® Grab Sampling Systems

Configurable. Local. Reliable.



Swagelok®

What Is Grab Sampling	3	Supply Chain and Quality	18
Specifying a Grab Sampling System	4	Global Distribution Network	19
Why Swagelok for Grab Sampling	6	Inventory and Availability	20
Grab Sampling Solutions	7	Traceability and Quality	21
Grab Sample Module (GSM)	8	Swagelok Promise	22
Grab Sample Liquid (GSL)	9	Contact Us	23
Grab Sampling Cylinders (GSC)	10		
Grab Sampling Accessories	11		
Grab Sampling Support	12		
Assess	13		
Recommend	14		
Configure	15		
Assemble	16		
Train	17		



What Is Grab Sampling?

Grab sampling, also known as lab sampling or spot sampling, is the collecting of a sample of liquid or gas in a pipeline, tank, or system with the intent of transporting the sample to a laboratory for analysis.

When properly conducted using the right equipment, grab sampling can help you:

- Validate process conditions
- Verify whether online analyzers are fit for use
- Ensure end products meet quality specifications
- Determine product quality during custody transfer
- Provide verification of environmental emissions
- Protect against sample evaporation or fractionation during transport



Specifying a Grab Sampling System

There are a variety of approaches that can be used to extract samples. To ensure you receive a representative sample without injury to operators or damage to equipment, consider:

- **Pressure:** Each grab sampling system has a maximum rated pressure not to be exceeded
- **Temperature:** Each grab sampling system has a maximum fluid operating temperature, and some have minimum operating temperatures
- **Process phase:** Some grab sampling assemblies are suitable for either liquid or vapor systems while others are designed only for nonvolatile liquids

[See more >](#)

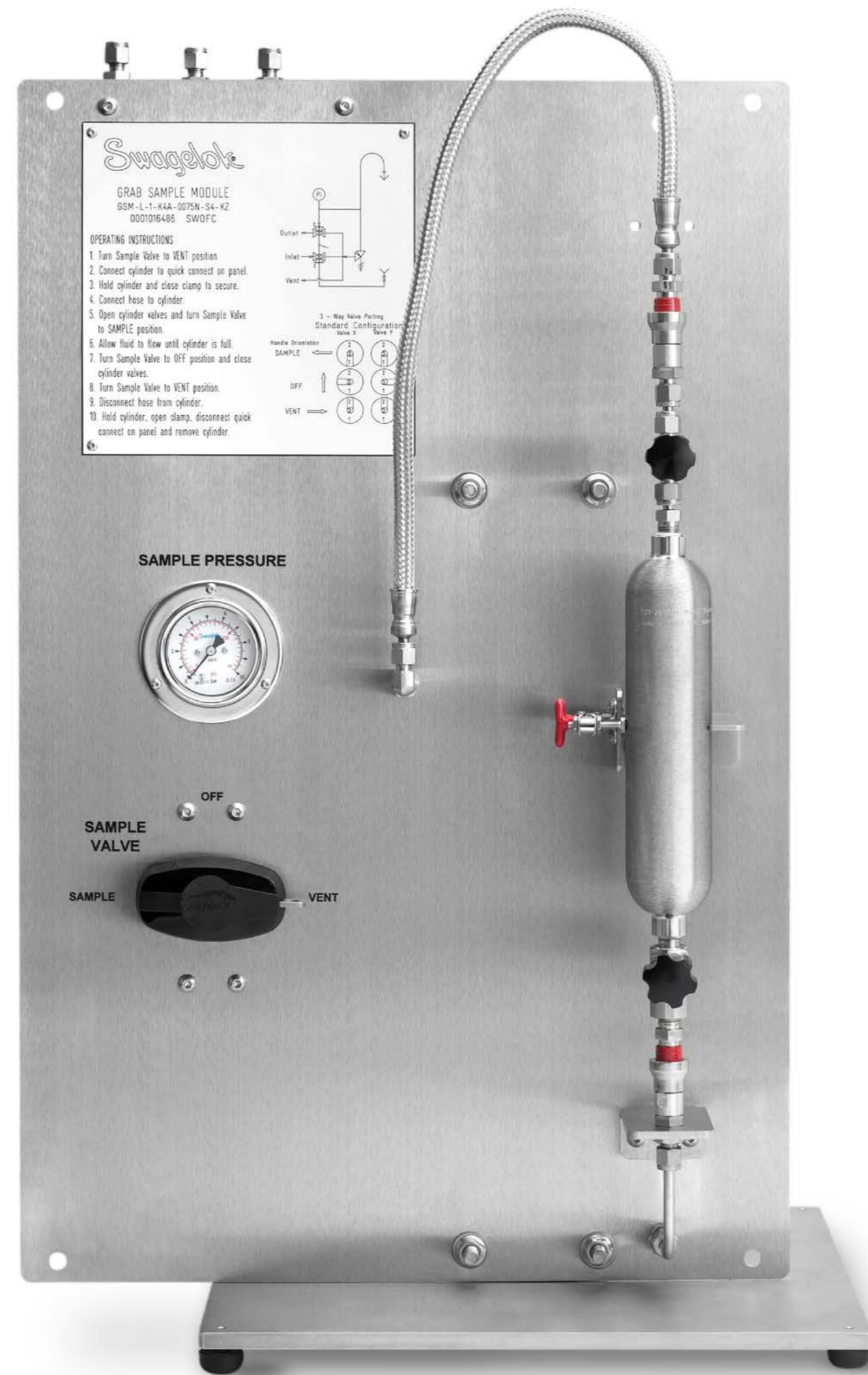

Specifying a Grab Sampling System (continued)

There are a variety of approaches that can be used to extract samples. To ensure you receive a representative sample without injury to operators or damage to equipment, consider:

- **Hazardous or flammable properties:** The sampling system must provide sufficient protection from fluids for the operator and environment
- **Chemical makeup and consistency:** The materials, coatings, and containers used in sampling systems must be compatible with the sample fluid
- **Surface treatment needs:** Electropolished or coated components can reduce the absorption or adsorption of fluid into metal surfaces
- **Purge requirements:** Determine whether a purge fluid will be needed to remove residual contamination from sample lines



Why Swagelok for Grab Sampling?

We understand what it takes to build safety, ease of use, and reliable performance into grab sampling systems, whether that means building assemblies for you or advising on sampling practices. Look to Swagelok for:

- Unparalleled sampling expertise
- Local assembly and support
- A simple, effective way to safely collect samples
- The ability to keep samples in their representative state
- Standard designs built according to best practices
- Configurable to meet system requirements
- Assembly and testing by certified technicians
- Ease of installation, operation, and maintenance
- One supplier for all components and single part numbers for assemblies
- Backed by the Swagelok Limited Lifetime Warranty



Grab Sampling Solutions

Swagelok offers two types of grab sampling systems that provide gas and liquid non-slurry sampling service in consistent, reliable packages.

- The Swagelok® grab sample module (GSM) is a sampling panel that uses sealed, metal, pressure-containing cylinders to capture either liquid or gas
- The Swagelok® grab sample liquid (GSL) is a liquid-only sampling system for drawing fluid into a non-pressure containing bottle with a self-sealing septum cap

Designed for Safety

Both sampling system types are available in fixed-volume versions that separate the process pressure from the sample bottle and user, preventing overfilling and overpressure conditions.



Grab Sample Module (GSM)



Grab Sample Liquid (GSL)

Grab Sample Module (GSM)

The GSM closed-looped sampling system pulls from a positive-pressure process and returns back to the process at a lower pressure location, using differential pressure to drive the fluid through the system.

- The continuous flow configurations allow the sample transport lines to continue flowing while sampling
- The GSM left in the bypass or sample position indefinitely keeps transport lines fresh and ready for sample capture
- A grab sampling cylinder (GSC) is docked, and process fluid is continuously circulated within to maintain process conditions



Front View



Rear View



Two-Valve Switching Valve



Three-Valve Switching Valve

Designed for Reliable Results

GSM panels feature a switching valve configuration with two or three Swagelok® 40G series ball valves, allowing for simultaneous control of fluid routing. These configurations reduce the number of sequencing steps required for sampling and give a clear indication of sequencing to the operator, reducing the likelihood of errors.

Grab Sample Liquid (GSL)

A liquid-only sampling system can be used in liquid applications where the process fluid is not at risk of fractionating when stored at atmospheric pressure.

- The GSL can use lower-cost glass or polyethylene laboratory bottles to draw and store samples
- Using bottles can provide immediate feedback on the visual quality of the sample stream
- Samples can be drawn and transported without the risk of spillage or evaporation

Designed for Ease of Use

Swagelok GSL systems use the same switching valve as a GSM system to provide simplified operation for complex tasks. A spring-return handle on the sample drawing mechanism prevents unintentional dispensing.

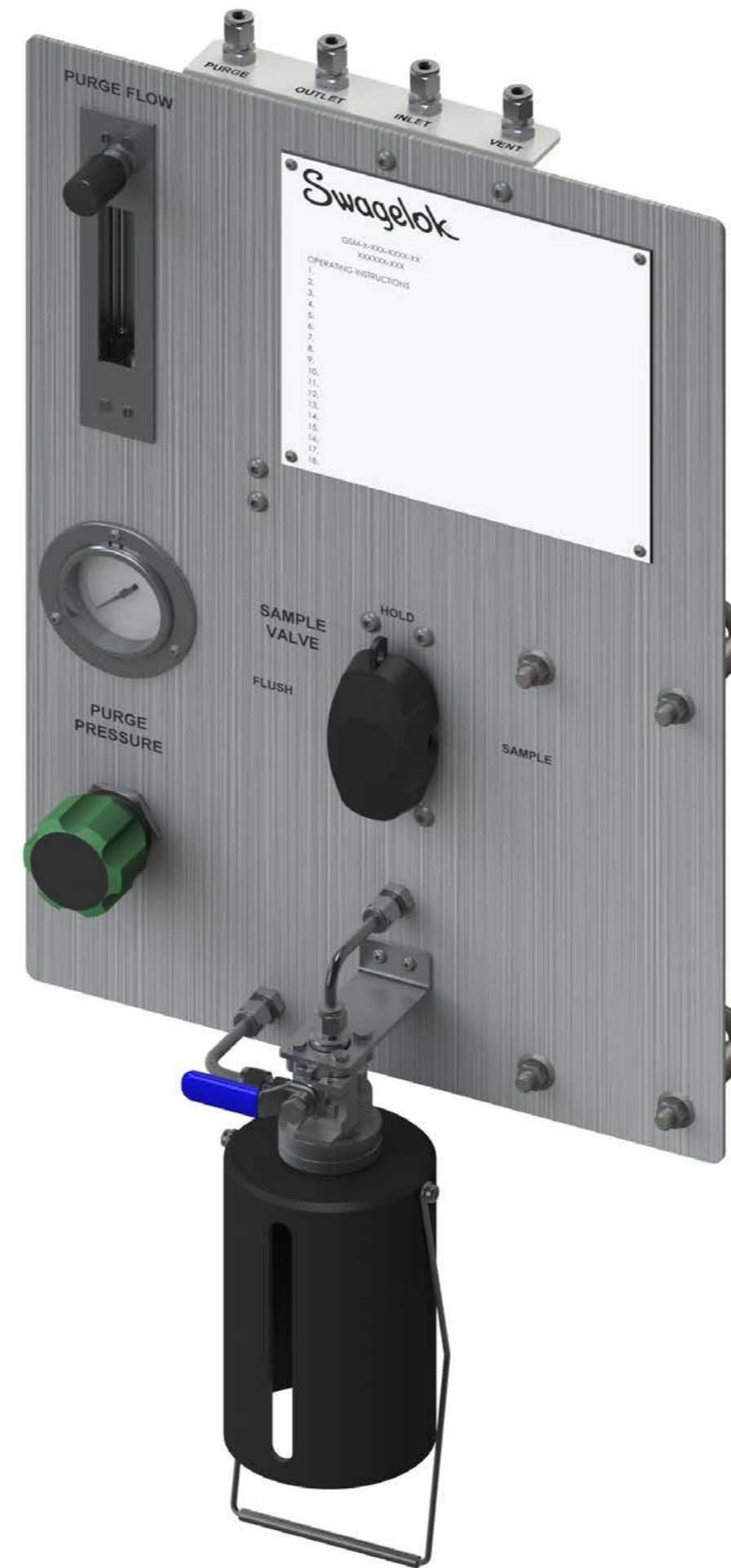

Front View



Rear View

Grab Sampling Cylinders (GSC)

A sample cylinder, which continuously circulates samples to maintain process conditions and increase the chances of a representative sample, is required for every GSM system. Various configurations of these grab sample cylinders (GSC) are available:

- Five standard cylinder sizes (150, 300, 400, 500, and 1000 cm³)
- Multiple cylinder and valve material options
- With or without purge bypass tube
- Cylinder treatment/certification options
- Stem and body protectors
- Choice of quick-connect fittings and accessories (outage tubes, rupture discs, handles)
- PTFE-coated inner wall, SilcoNert[®] coating, or electropolished inner diameter
- DOT- or TPED-approved for transportation

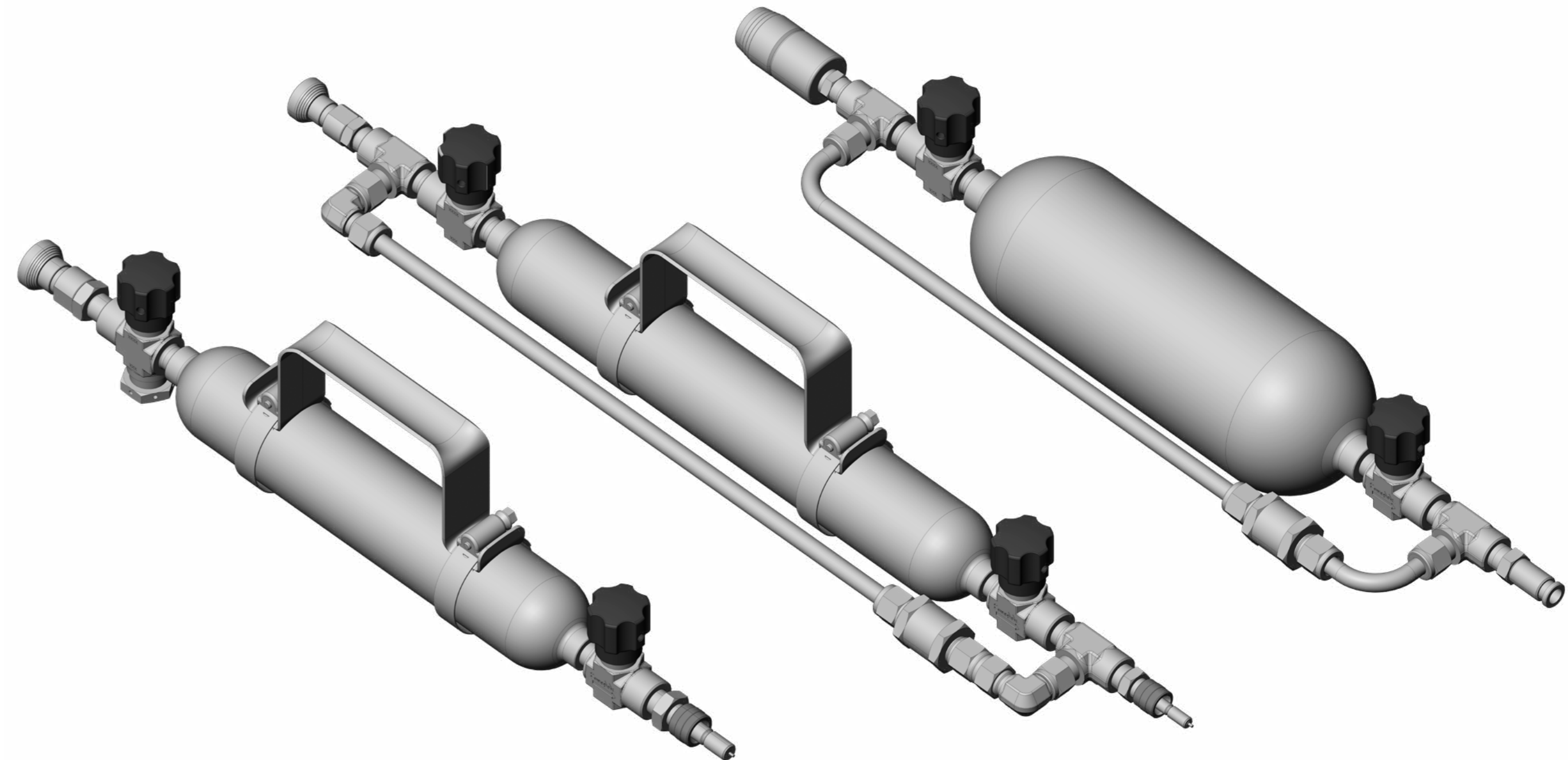

Grab Sampling Accessories

Swagelok® grab sampling systems can be customized with a variety of accessories to suit your operations, including:

- Additional instrumentation (gauges, flowmeters, and transducers)
- Sample coolers
- Process connections (threaded and flanged)
- Enclosures and stands
- Automation
- Exotic alloys (certain components are available in alloy 400, alloy C-276, or alloy 600)
- Outage tubes
- Nonrotating stem needle valves
- Rupture disc units
- Relief valves
- Carrying handles



Grab Sampling Support

Your local authorized Swagelok sales and service center team will work with you to determine the type of panel and the proper configuration to meet your sample system needs. Each grab sampling panel will be built to your specifications at your local Swagelok sales and service center by experienced fluid systems professionals.

To find the right solution for you, we will:



Assess

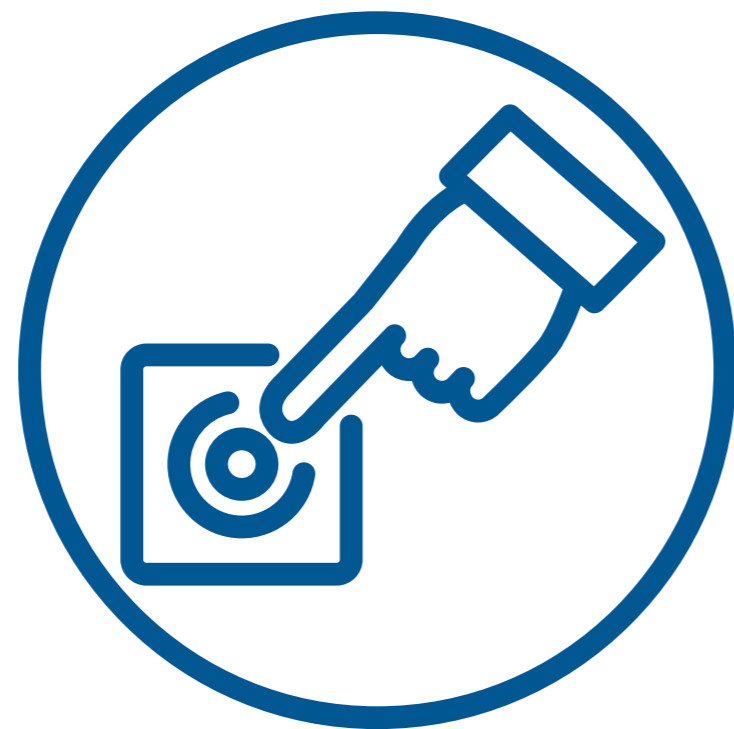

Recommend



Configure



Assemble



Train



We Assess

Our team of highly trained and certified technicians and engineers will evaluate your current sampling system and assess your needs to help you capture representative samples quickly and cost-effectively.

Looking for a more in-depth analysis of your sampling practices and equipment? Through Swagelok® grab sampling evaluation and advisory services, our grab sampling experts can visit your facilities to evaluate your systems and advise on:

- Enhancements that will improve your operational performance
- Ways to eliminate potential safety and environmental concerns
- Opportunities to obtain more representative samples and improve system reliability
- Recommended next steps based on a detailed report of findings





We Recommend

Our team will take you through a checklist of details to ensure you receive a sampling panel that meets your needs. We will evaluate your system parameters, including:

- Temperature
- Pressure
- Phase compatibility
- Container type
- Materials of construction
- Installation location

Based on the established parameters, a certified Swagelok professional will review your information and recommend the right panel for you.

Swagelok Grab Sample System Checklist:
 Swagelok Oklahoma | West Texas

Grab Sampling can validate process conditions, ensure end products meet quality specs, determine product quality during custody transfer and provide verification of environmental emissions.
Trust Swagelok Grab Sampling Systems when capturing a representative sample is essential.
 Please answer with the dropdown menu to the best of your knowledge in regards to your Sample System requirements.

Grab Sample Module (GSM) & Cylinder (GSC)
 Grab Sample Liquid (GSL)
 Quantity

Customer Information:

Company: Project Name: Sales Rep:
 Contact: Email: Phone:
 Today's Date: Date Bid Due: Need by Date:

Process Fluid Data:

Gas Liquid Process Fluid: Fluid Hazard Conditions
 Min/Max Pressure Min/Max Temp
 Inlet Pressure Inlet Temp
 Outlet Pressure Outlet Temp
 Vent/Flare Pressure Viscosity at Temp
 Purge Pressure Tag#'s
 Condensable? Yes No At what Temp? Particulates? Yes No Size?

Materials of Construction:

Panel Components Tubing Seal Material
 Other: Other: Other:

Sample Station Options:

Cylinder	Boston Round Bottle	Media Bottle	Cylinder Material
Quantity: <input type="text"/>	Quantity: <input type="text"/>	Quantity: <input type="text"/>	<input type="text"/>
Size: <input type="text"/>	Size: <input type="text"/>	Size: <input type="text"/>	Bottle Description
Other: <input type="text"/>	Other: <input type="text"/>	Other: <input type="text"/>	<input type="text"/>

Replacing Existing Station	No <input type="checkbox"/>	Yes <input type="checkbox"/>	Supplier	Model
Continuous Flow	No <input type="checkbox"/>	Yes <input type="checkbox"/>		
Purge	No <input type="checkbox"/>	Yes <input type="checkbox"/>		
Relief Valve	No <input type="checkbox"/>	Yes <input type="checkbox"/>		
Check Valves	No <input type="checkbox"/>	Inlet <input type="checkbox"/>	Outlet <input type="checkbox"/>	Vent <input type="checkbox"/> Purge <input type="checkbox"/>
Isolation Valves	No <input type="checkbox"/>	Inlet <input type="checkbox"/>	Outlet <input type="checkbox"/>	Vent <input type="checkbox"/> Purge <input type="checkbox"/>
Block Valves	No <input type="checkbox"/>	Inlet <input type="checkbox"/>	Outlet <input type="checkbox"/>	
Flowmeter	No <input type="checkbox"/>	Yes <input type="checkbox"/>		
Outage Tube	No <input type="checkbox"/>	Yes <input type="checkbox"/>	Minimum Outage	<input type="text"/> %
Rupture Disc	No <input type="checkbox"/>	Yes <input type="checkbox"/>		
Gauges	No <input type="checkbox"/>	Pressure <input type="checkbox"/>	Temp <input type="checkbox"/>	General Industrial <input type="checkbox"/> Safety <input type="checkbox"/> Process <input type="checkbox"/>
Inlet/Outlet Connections	1/4" <input type="checkbox"/>	3/8" <input type="checkbox"/>	Other	<input type="text"/>
Sample Cooler	No <input type="checkbox"/>	Yes <input type="checkbox"/>	Cooling Media	<input type="text"/> Operating Temp <input type="text"/>
Mounting	Wall <input type="checkbox"/>	Pipe <input type="checkbox"/>	Stand Qty	<input type="text"/>
Enclosure	No <input type="checkbox"/>	Yes <input type="checkbox"/>	Insulated <input type="checkbox"/>	Heated? <input type="checkbox"/> Steam <input type="checkbox"/> Electric Material <input type="checkbox"/>
Panel Material	SS <input type="checkbox"/>	Aluminum <input type="checkbox"/>	Other	<input type="text"/> Decal <input type="text"/>
Quick Connects	No <input type="checkbox"/>	QC4 <input type="checkbox"/>	QTM2 <input type="checkbox"/>	QC6 <input type="checkbox"/> Other <input type="text"/>

Swagelok Oklahoma | West Texas
[SUBMIT RESULTS HERE](#)





We Configure

Using our standard panel designs as a platform, we can work with your team to:

- Substitute comparable Swagelok and non-Swagelok products
- Add products within the existing schematics (sample coolers, flowmeters, shutoff valves, drain valves, etc.)
- Make changes in layout
- Make structural changes/additions (panel/bracket materials, enclosures, etc.)
- Convert to larger/smaller tube size (or metric)
- Suggest alternative materials of construction
- Discuss flow/pressure drop calculations (and make changes based on results)
- Suggest sizing of sample coolers/heaters and enclosure heaters





We Assemble

We take the work of sampling system assembly off your team, fabricating the system and testing for reliability. Every local Swagelok technician undergoes comprehensive training and certification to ensure your sample panel adheres to strict guidelines and to your specifications.

Our certified engineer will monitor each step of the process to ensure quality and consistency.

- Every Swagelok GSM and GSL is shell tested at the selected gauge pressure of the assembly, up to a maximum of 1000 psig (69 bar)
- Additional testing is available upon request
- Fabrication inspectors perform first-piece, in-process, and final inspection of orders
- All Swagelok products are backed by the [Swagelok Limited Lifetime Warranty](#)





We Train

We are committed to helping you work safer and smarter, providing hands-on training on grab sampling system use and maintenance for your technicians once your panels are assembled.

Interested in further training on industrial sampling systems? We can help there, too. Further equip your team with the knowledge to prevent, diagnose, and eliminate costly issues with Swagelok® sampling system training that is based on the teaching of industry expert Tony Waters:

[Process Analyzer Sampling System \(PASS\) Training](#)

[Process Analyzer Sampling System \(PASS\) Subsystem Training](#)

[Sample System Problem Solving and Maintenance \(SSM\)](#)



Our Supply Chain and Quality

We are positioned to support your success wherever your operations take place.

- Our global distribution network operates in 70 countries from 225 sales and service centers, 20 manufacturing facilities, and 5 global tech centers
- Our local associates know the culture, speak the language, and understand the region, getting you what you need when you need it
- Approximately 7800 associates across the globe provide the manufacturing, field engineering, technical services, logistical support, and special expertise you need

With our inventory availability and interconnected global team, you are never far from the products you need.



Global Distribution Network

We know that consistent inventory availability is crucial to keep your operations running smoothly and on budget, and we have built our global distribution base to deliver under pressure:

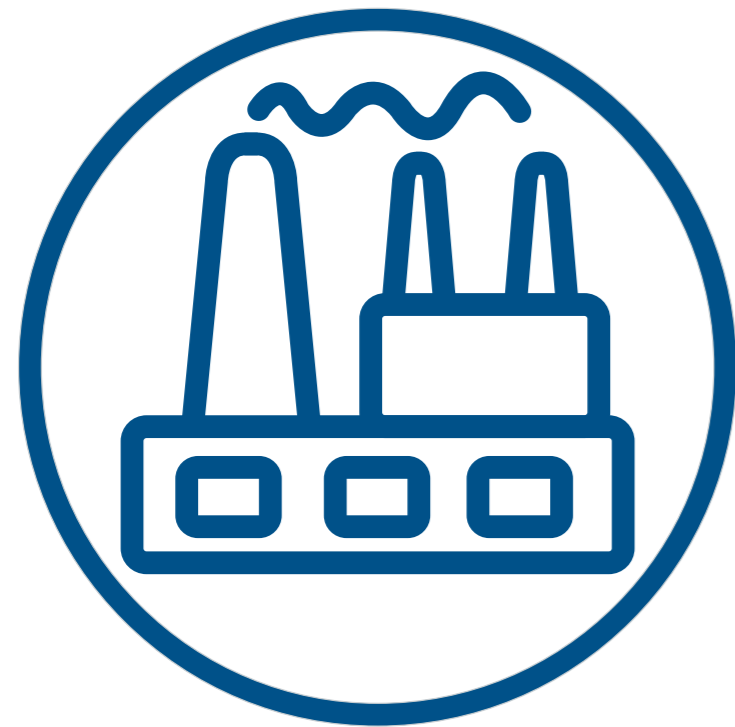

20 Manufacturing Centers

The Swagelok advantage starts with highly reliable components machined from high-quality raw materials



Distribution Warehouses

Deliver direct to your local sales and service center with 99% inventory and shipping accuracy



225 Sales and Service Centers

Autoreplenishment and sales forecasting support regional inventory levels so you have access to what you need



100 000s of Customers Worldwide

Enjoy fast access to the products that keep plants and processes running safely and reliably

Inventory and Availability

Availability is a critical part of our brand promise. We ensure our sales and service centers have the right level of inventory for the products you need immediately:

- Thousands of standard products in inventory
- Over 6800 line items shipped daily
- 99% shipping and inventory accuracy

We also collaborate with key customers to supply:

- Short lead times on assemble-to-order (ATO) products
- A robust supply of make-to-order (MTO) products
- Engineer-to-order products (ETOP) for unique needs

It's Only Fitting

Swagelok keeps significant amounts of raw materials in case of supply chain interruption. We also have a team of 35 professionals working with our suppliers to overcome any issues.



Traceability and Quality

Raw material traceability is an integral part of Swagelok's overall quality system throughout all phases of material receipt, manufacturing, processing, storage, and delivery. All fittings are marked with the Swagelok name, material type, and trace identifier.

The quality system our fittings are manufactured under has been approved by:

- ISO 9001:2000
- UN/ECE R110
- METI/KHK
- Canadian Registrations
- CSA NGV 3.1 and 4.6
- ASME N and NPT
- The U.S. Navy
- DNV GL (Det Norske Veritas)
- American Bureau of Shipping
- The Bureau Veritas
- Lloyd's Register



A Promise As Strong As Our Products

The Swagelok Limited Lifetime Warranty demonstrates our relentless commitment to quality and our customers. Every Swagelok product is backed by this promise for the life of the product, so you can rest assured that your fluid system investment is protected.

[Learn more about our warranty](#)



Contact Us

Whether you need reliable grab sampling assemblies, supporting services to optimize your sampling processes, or training to help you cost-effectively manage your sampling processes, we can help.

[INSERT YOUR LOCAL CONTACT INFORMATION HERE](#)

