

Swagelok Hose Quick Reference Guide

Considerations for Selecting a Hose Assembly Solution

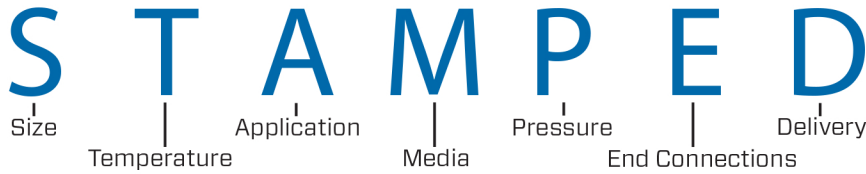

Temperature: What are the min. and max. temperatures the hose will be exposed to with regard to the media and environment?

Pressure: What are the the min. and max. pressures (or vacuum) within and outside the hose assembly?

Desired Flow: Consider desired flow. Hose connection size, core tube construction, and routed installation may all impact flow.

Material: Identify the system media and the environment. This will help determine the materials of construction.

Movement: Will the hose be installed in a dynamic application? If so, this will require different considerations.

Drainability: Consider core construction as this will impact drainability.

Length: Determine the most likely route for installation of the hose, and use this to identify length requirements.

Orientation: Clarify any space constraints. Hose assemblies with elbows and union ball joints may help resolve these issues.

Special Markings: Are any special markings required, such as tagging?

Series	Nominal Hose Size, in.										Temperature Range °F (°C)
	Working Pressure at 70°F (20°C), psig (bar)										
	1/8	3/16	1/4	3/8	1/2	3/4	1	1 1/4	1 1/2	2	
Metal Hose											
FM	—	—	3100 (213)	2000 (137)	1800 (124)	1500 (103)	1200 (82.6)	950 (65.4)	900 (62.0)	500 (34.4)	-325 to 850 (-200 to 454)
FJ	—	—	1600 (110)	1470 (101)	1110 (76.4)	860 (59.2)	680 (46.8)	680 (46.8)	520 (35.8)	450 (31.0)	-325 to 800 (-200 to 426)
Fluoropolymer (Teflon) Hose											
T	—	—	3000 ^① (206)	2500 (172)	2000 (137)	1500 (103)	1000 (68.9)	—	—	—	-65 to 450 ^② (-53 to 230)
C	—	—	—	—	1500 (103)	1100 (75.7)	750 (51.6)	—	700 (48.2)	525 (36.1)	
X	—	—	3500 (241)	3000 (206)	1800 (124)	1250 (86.1)	1000 (68.9)	—	—	—	
S	3000 (206)	—	3500 (241)	3000 (206)	1800 (124)	1250 (86.1)	1000 (68.9)	—	—	—	

① T series hose with alloy 400 braid is rated to 1500 psig (103 bar).

② C series hose is rated from -20 to 340°F (-28 to 171°C) in the 1 1/2 and 2 in. nominal hose sizes.

Industry	Value Proposition	Series	Key Feature(s)	Patented	Pressure Range PSI (BAR)	Size	Inner-core	Cover
General Industrial	The flexibility of the X series product is far better than other competitive smoothbore PTFE stainless steel braided designs	X	Flexibility	Yes	1000 - 3500 (68.9 - 241)	1/4 - 1 inch	Smoothbore PTFE	Stainless
	FJ/FM are flexible solutions for gas applications where permeability and/or temperature is a concern	FJ/FM	Permeation Resistance/Temp	No	450 - 3100 (31.0 - 213)	1/4" - 2 inch	Convuluted Metal	Stainless
Chemical	The convoluted inner core design offers extreme flexibility with the benefits of PTFE's compatibility. Larger sizes hoses are often required in chemical; > 3/4 inch	C	Flexibility	No	525 - 1500 (36.1 - 103)	1/2 - 2 inch	Convuluted PTFE	Stainless
Pharm/Biotech	Smoothbore PTFE is required because of purity requirements, but PTFE is typically not flexible. The U & S series hoses offer superb flexibility and come with smooth silicone covers for external cleanability. S series is good in 1/8 thru 3/4 inch sizes. U series is recommended in 1 thru 2 inch sizes. Ideal for load cell / weigh scale applications and steam lines where exterior insulating protection may be required	S	Flexibility/smooth silicone cover/cleanable	Yes	1000 - 3000 (68.9 - 206)	1/8 - 1 inch	Smoothbore PTFE/PFA	Silicone
		U			150 - 300 (10.3 - 20.6)	1/2 - 2 inch		
Laboratory	The availability of these products in 1/8 inch size makes them ideal for laboratory lines. Benefits of Teflon with extreme flexibility	S	Available in 1/8 inch size	Yes	1,000 - 3,000 (68.9 - 206)	1/8 inch	Smoothbore PTFE	Silicone

Swagelok Hose Quick Reference Guide

Swagelok Hose and Flexible Tubing Installation and Use Guide

Inspection

Establish an inspection schedule based on system application and replacement history.

Electrostatic Discharge

Static electricity can be generated by fluid passing through the hose. Select hose with sufficient conductivity to ground the static electric charge and allow static dissipation. If static electricity generation is possible within an application, choose static dissipative hose and properly ground to earth.

Vibration

Evaluate amount of system vibration when selecting hose. Metal hose may not be appropriate for systems with constant or severe vibration.

Length

Take into consideration hose movement, system pressurization, and thermal expansion when determining hose length. Installing hose that does not have sufficient length to accommodate these factors may reduce hose life.

Minimum Bend Radius

Follow minimum bend radius requirements for your hose. Installing hose with smaller bends may kink hose and reduce hose life.

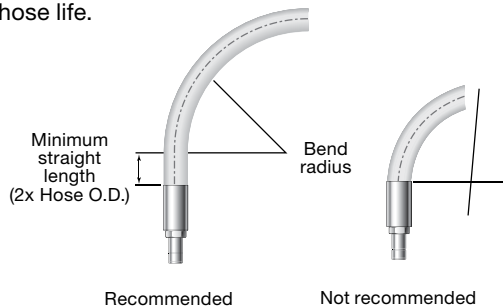

Hose rupture or leakage may result from bending too close to the hose/fitting connection.

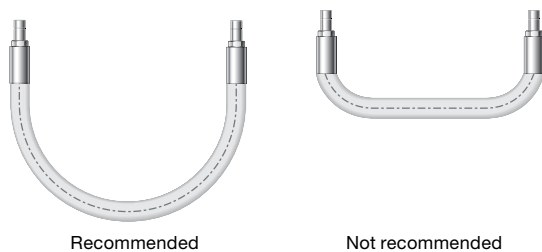

Hose Strain

Elbows and adapters can be used to relieve hose strain.

Motion Absorption

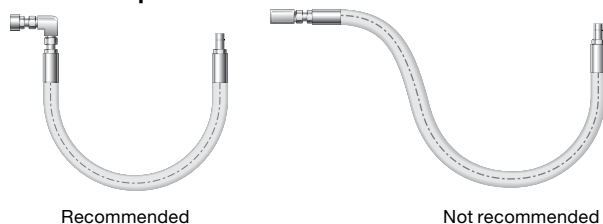

For additional information, see SAE J1273, *Recommended Practices for Hydraulic Hose Assemblies*.

Distribute movement and prevent bends smaller than the hose's minimum bend radius by providing sufficient hose length.

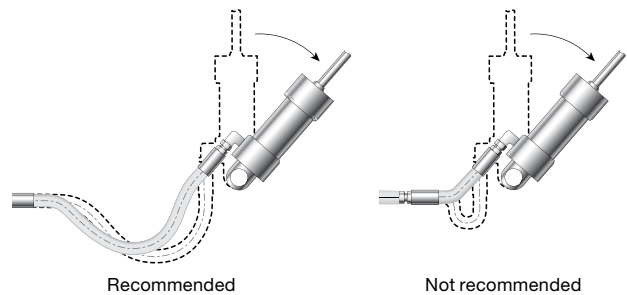

Machine Tolerance

Allow for changes in length resulting from machine motion and tolerances.

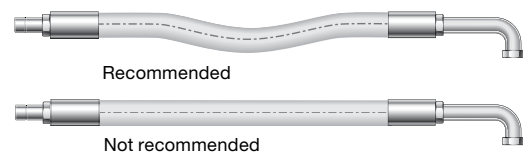

System Pressure Changes

Allow sufficient hose length to accommodate changing system pressures. Do not connect high- and low pressure hoses.

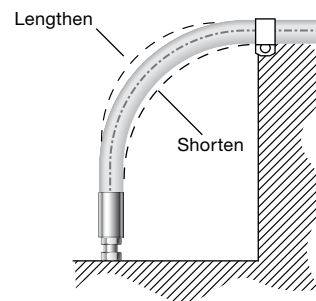

Bending in One Plane

Avoid twisting the hose by bending it in one plane only. For a compound bend, use multiple hose pieces or other isolation methods.

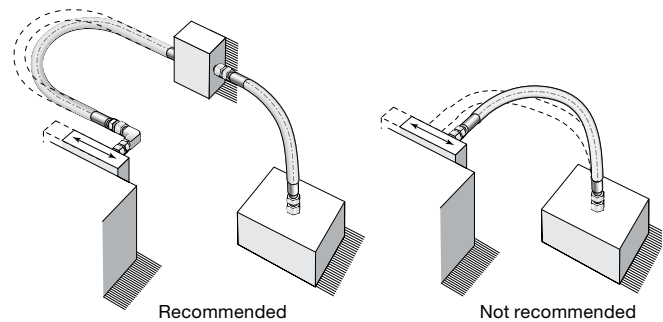

Images on this page reprinted with permission from SAE J1273.
© 2009 SAE International.
F-HOSE-002-V1

