

# Mechanical Seal Support Systems

API 682 Seal Plans

Application Guide

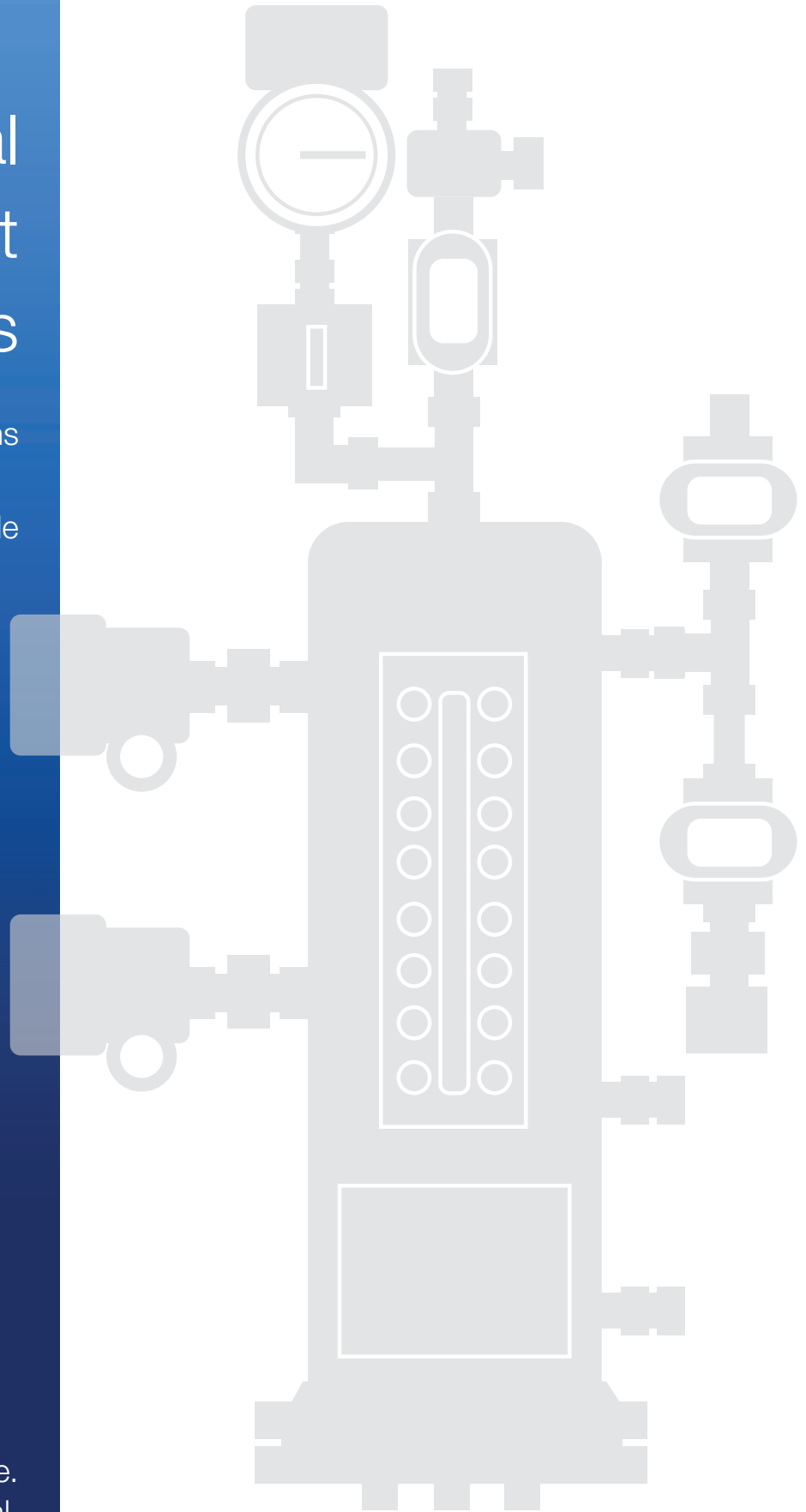

Configurable.  
Local.  
Reliable.

Swagelok®

## Contents

<b>What is a Seal Support System?</b> .....	3	<b>Between Seal Plans</b>	
<b>API 682</b> .....	3	<i>Plan 52 Buffer Fluid Seal Pot</i> .....	31
<b>Seal System Design Principles</b> .....	3	<i>Plan 53A Barrier Fluid Seal Pot Pressurized by Nitrogen</i> .....	35
<b>Swagelok Seal Support Systems</b> .....	5	<i>Plan 53B Barrier Fluid Pressurized by Bladder Accumulator</i> .....	39
<b>Schematic Symbol Definitions</b> .....	6	<i>Plan 53C Barrier Fluid Pressurized by Piston Accumulator</i> .....	43
<b>Swagelok Seal Plan Components</b> .....	7	<i>Plan 54 Barrier Fluid Pressurized by External System</i> .....	47
<b>Process Side Plans</b>		<i>Plan 55 Buffer Fluid Circulated by External System</i> .....	51
<i>Plan 11 Flush</i> .....	11	<i>Plan 72 Buffer Gas</i> .....	55
<i>Plan 12 Flush with Strainer</i> .....	13	<i>Plan 74 Barrier Gas</i> .....	59
<i>Plan 13 Flush from Chamber to Suction</i> .....	15	<i>Plan 75 Condensing Leakage Collection</i> .....	63
<i>Plan 14 Flush, Combination of Plans 11 and 13</i> .....	17	<i>Plan 76 Noncondensing Leakage Collection</i> .....	67
<i>Plan 21 Cooled Flush</i> .....	19	<i>Plan 72/76 Buffer Gas and Noncondensing Leakage Collection</i> .....	71
<i>Plan 22 Cooled Flush with Strainer</i> .....	21	<b>Atmospheric Side Plans</b>	
<i>Plan 23 Cooled Flush, Recirculated through Seal Chamber</i> .....	23	<i>Plan 51 Quench from Reservoir</i> .....	75
<i>Plan 31 Flush with Cyclone Separator</i> .....	25	<i>Plan 62 Quench from External Source</i> .....	77
<i>Plan 32 External Flush</i> .....	27	<i>Plan 65A Leakage Collection with Reservoir</i> .....	79
<i>Plan 41 Cooled Flush with Cyclone Separator</i> .....	29	<i>Plan 65B Leakage Collection with Reservoir</i> .....	81
		<b>Glossary</b>	
		<i>Swagelok Component Literature</i>	
		<i>Reference</i> .....	83

## What is a Seal Support System?

Seal Support Systems are each designed for a specific mechanical seal and set of process conditions. These systems supply either a gas or a liquid to the mechanical seal to regulate the environment in which the seal operates, protecting rotating equipment from damage. These systems have four main functions:

- Provide lubrication to seal faces
- Control pressure and temperature in the seal chamber and seal
- Flush the seal of contamination and/or residue build up
- Prevent system process fluid from leaking to atmosphere

## API 682

Guided by API 682: *Pumps - Shaft Sealing Systems for Centrifugal and Rotary Pumps*, Swagelok seal support system designs avoid pipe threads and limit the number of connections wherever possible. Based on the fourth edition, the standard design for each plan includes the minimum arrangement of components as detailed in API 682.

## Seal System Design Principles

Where beneficial for system troubleshooting, maintenance, or safety, additional options are available for Swagelok seal support systems. The addition of isolation valves, bypass loops, and instrumentation are available to assist the pump operator in both maintaining the system and monitoring the health of the seal.

## Reliability and Maintenance

Proper system start-up and commissioning are critical for the operation of mechanical seals and their associated support systems. The inclusion of air within the system at start-up can lead to issues with the seal support system. Flow can be disrupted or stopped in systems with chillers or seal pots. Air inclusions can also prevent the support system from providing the desired rate of cooling. Including high-point vents in the seal support system allows the system to be vented and cleared of entrapped air.

System maintenance during turnarounds and projects requires seal support systems to be drained for servicing. When taking a pump out of service, low point drains allow the system to be purged of buffer, barrier, or flush fluids, quickly and safely.

Pressure and temperature measurement devices help plant personnel understand what is happening in the seal chamber and seal support system. Many Swagelok seal support systems offer additional instrumentation options at points where measuring either pressure or temperature would assist in troubleshooting an issue or provide other operational benefit.



Fig. 1  
API Plan 52

## Appropriate Flow

Whether the system delivers a flush fluid to the inboard seal or buffer and barrier fluids are circulated between seals in a dual seal arrangement, maintaining proper flow and circulation through the support system and seal chamber is a requirement for effective seal operation. A common flow issue is clogged orifices, which can cause a loss of flush fluid to the seal chamber, resulting in seal failure. Additionally, improper circulation of buffer and barrier fluids can also cause operational issues due to lack of appropriate system cooling.

When designing seal support systems, it is important to have pressure drop and flow control happen at appropriately engineered locations, such as orifices and flow control valves. Components such as filters and strainers can become clogged and create unwanted flow restrictions in seal support systems. These serviceable items should be located in areas that are easy to access and maintain. Additional options such as bypass loops can be added to the system to ensure a continued supply of flush fluid when a filter or strainer element is being replaced or cleaned.

In addition to individual system components that will need to be serviced, the design of tubing runs should be considered critical to the effectiveness of seal support systems. All tubing runs should be sloped, especially those running to and from the seal. A half inch per foot (40 mm per meter) of slope is recommended. One-half inch (12 mm) OD tubing is acceptable for differential pressure or pumped flow systems, while three-quarter inch (18 mm) tubing is recommended for systems utilizing a pumping ring or a thermo-siphon effect. It is best practice to eliminate the use of elbow fittings and to use large-radius bends in the tubing to further assist flow.

## System Safety

API 682 recommends specific wall thicknesses for 1/2 inch (12 mm) to 1 inch (25 mm) OD tubing. While thinner-walled tubing, such as that used in general instrumentation installations, is often sufficient to handle the pressure and temperature of seal support systems, heavier-wall tubing provides extra rigidity in high-vibration service. Tubing with a heavier wall also creates systems that are more robust in areas where large pieces of equipment are being maintained and personnel may inadvertently come into contact with the tubing.

In contrast to larger liquid systems which mainly use 1/2 inch (12 mm) and 3/4 inch (18 mm) tubing, API 682 offers no guidance regarding tubing wall thickness for systems under 1/2 inch (12 mm). Tubing wall thickness for 1/4 inch (6 mm) and 3/8 inch (8 mm/10 mm) systems can be selected from Swagelok's *Tubing Data Sheet*, MS-01-107, based on the pressure and temperature of the service. These systems are typically nitrogen filtering and regulating systems for gas seal plans. Swagelok recommends these API gas plans are mounted on a panel with commonly serviced items such as filters and regulators placed with ease of maintenance in mind.

One final safety consideration when choosing the appropriate design for an API plan is the incorporation of block-and-bleed valves on all instruments, including gauges. This recommendation by API adds an additional level of safety for items that need to be calibrated or removed for servicing. Wherever practical, Swagelok seal support systems offer options for including 2-valve manifolds or other appropriate isolation on instruments.



## Swagelok Seal Support Systems

Swagelok seal support systems are offered as kits and assemblies.

### Seal Plan Kits

Seal plan kits (SPK) are a collection of components that are used to connect the seal support plan to the pump.

Due to the simplicity of the arrangement, the following API plans are offered only as a kit of components that are ready for field installation. These kits include all the necessary components to complete the plan:

- Process side plans: 11, 12, 13, 14, 21, 22, 23, 31, and 41
- Atmospheric side plans: 51, 62, 65A, and 65B

### Seal Plan Assemblies

Seal plan assemblies (SPA) are panels, seal pots, or skid systems that comprise the majority of each API seal support plan. The seal plan assembly ordering numbering structure allows for users to select a variety of configurations and additional system components to meet specific site or application requirements. Options and configurations not listed in the ordering numbering structure are also available. To configure those systems, please contact your authorized Swagelok sales and service center.































Seal plan assemblies can be ordered alone or with the associated field installation kit to provide a standard installation for site personnel. The following plans are offered fully assembled with a corresponding field installation kit also available for connecting the assembly to the pump:

- Process side plan 32
- Between seal plans 52, 53A, 53B, 53C, 54, 55, 72, 74, 75, 76, and 72/76

When procuring seal plan assemblies for pump installations or retrofits, please contact your authorized Swagelok sales and service center to ensure the proper amount of tubing and tube support materials are provided for a safe and effective installation.

## Schematic Symbol Definitions

The following symbols are used in the P&IDs of the API plans described in this application guide. Optional components will be shown in red in the P&IDs. Please use this page for reference.

	Open Needle Valve		Flow Orifice
	Closed Needle Valve		Y Strainer
	Open Ball Valve		Flowmeter with Control Valve
	Closed Ball Valve		Pressure-reducing Regulator
	Relief Valve		Filter
	Check Valve		Cyclone Separator
	Differential Pressure Indicator		2-Valve Manifold
	Differential Pressure Transmitter		Quick-connect
	Pressure Gauge		Level Gauge
	Pressure Transmitter		Cooling Coil
	Level Transmitter		Heat Exchanger
	Level Switch		Gear Pump
	Thermometer		Bladder Accumulator
	Temperature Transmitter		Diaphragm Accumulator
	Steam Trap Test Station		
	3-way Ball Valve		
	Piston Accumulator		

## Swagelok Seal Plan Components

Swagelok seal plan components help keep your rotating equipment running efficiently, with less downtime and fewer leaks. Our 2-inch and under components replace traditional threaded and welded pipe connections with bent tubing, tube fittings, and other quality parts<sup>1</sup>, like the components shown here. Custom configurations and critical spares are available through your local Swagelok sales and service center.

<sup>1</sup>API 682, 4th edition supports the use of tubing for mechanical seal support systems.

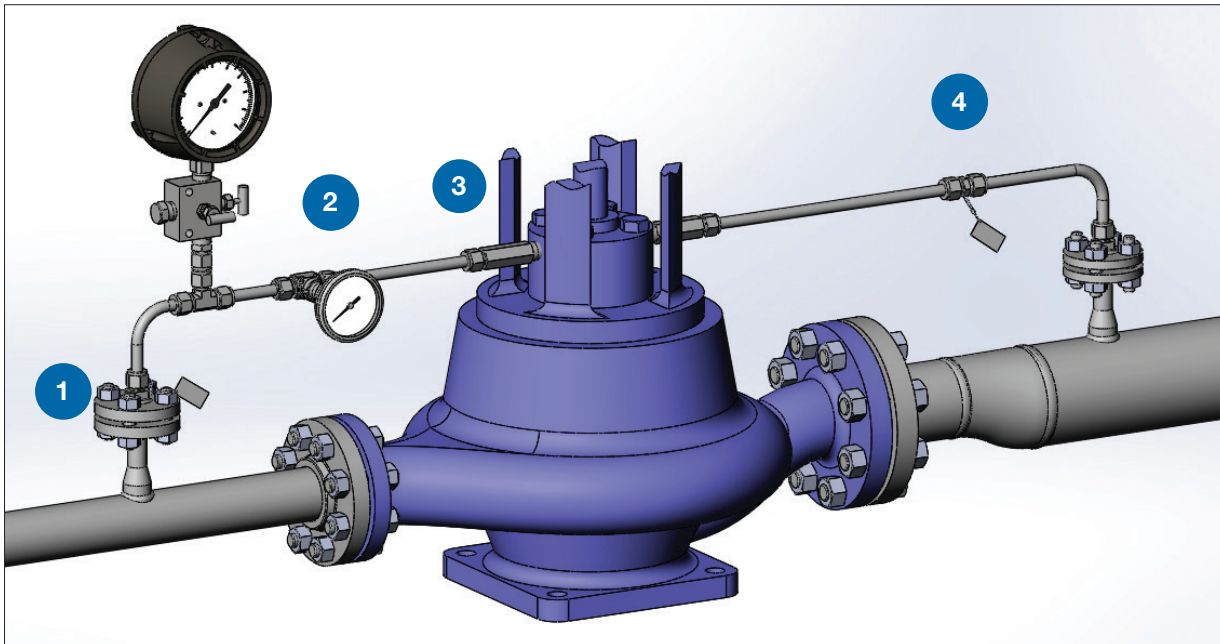

### 1 Integral Orifice Flange Adapter

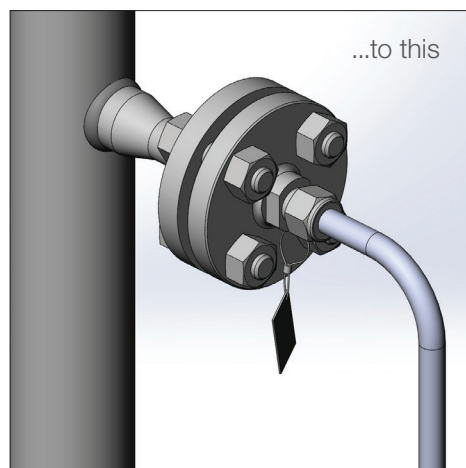
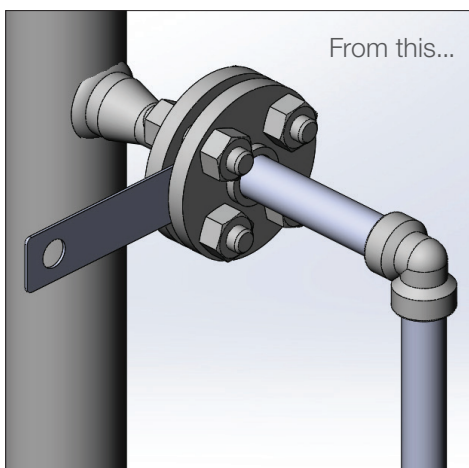

Replace threaded or welded flange assemblies with a one-piece flange adapter with an integral orifice.



**Integral Orifice Class 300 ANSI Flange Adapter with Tag Ordering Information**

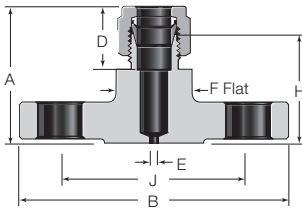

Tube OD	Flange Size	Ordering Number	Dimensions							Pressure Rating
			A	B	D	E	F	H	J	
<b>Dimensions, in. (mm)</b>										<b>psig (bar)</b>
1/2	3/4	SS-810-F12-300-43359	1.96 (49.8)	4.62 (117)	0.90 (22.9)	0.125 (3.2)	1.06 (26.9)	1.56 (39.6)	3.25 (82.6)	720 (49.6)
	1/2	SS-810-F8-300-43359	1.90 (48.3)	3.75 (95.3)				1.50 (38.1)	2.62 (66.5)	
3/4	3/4	SS-1210-F12-300-43359	2.04 (51.8)	4.62 (117)	0.96 (24.4)	1.50 (38.1)	1.64 (41.7)	3.25 (82.6)		
<b>Dimensions, mm (in.)</b>										
12	3/4	SS-12MO-F12-300-43359	49.8 (1.96)	117 (4.62)	22.9 (0.90)	3.2 (0.125)	26.9 (1.06)	39.6 (1.56)	82.6 (3.25)	49.6 (720)

**2 Thermowell Tee**

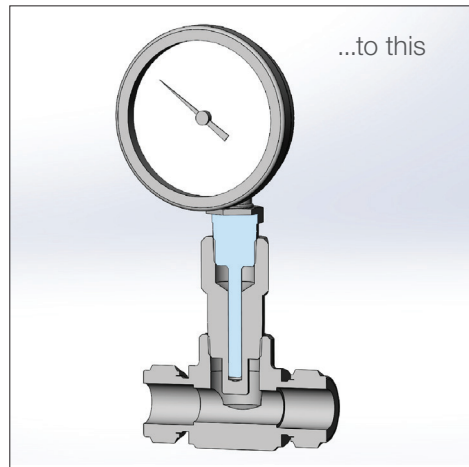
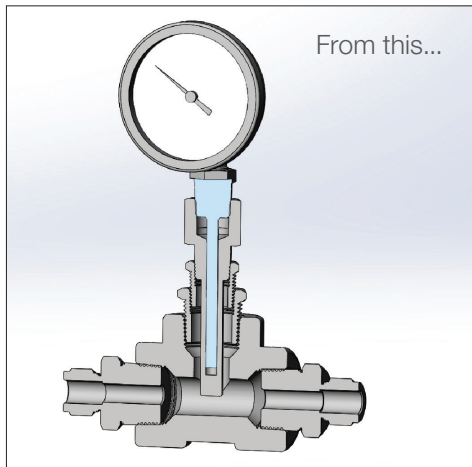

Reduce threaded connections and monitor temperature with integrated thermowell pre-welded into tube fitting tee for ease of installation.

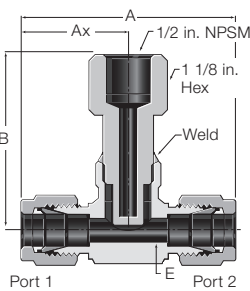

**Straight Pattern**

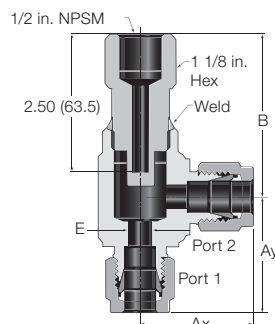

**Angle Pattern**

**Thermowell Tee Ordering Information**

Tube OD	Ordering Number	Dimensions					Pressure Rating
		A	Ax	Ay	B	E	
<b>Dimensions, in. (mm)</b>							<b>psig (bar)</b>
3/8	SS-TTW-S6	2.84 (72.1)	1.42 (36.1)	2.86 (72.7)	0.28 (7.1)	4900 (337)	
1/2	SS-TTW-S8 <sup>①</sup>	3.06 (77.7)	1.53 (38.9)				0.41 (10.4)
3/4	SS-TTW-S12 <sup>①</sup>	3.52 (89.4)	1.76 (44.7)	1.76 (44.7)	0.62 (15.7)	4600 (316)	
<b>Dimensions, mm (in.)</b>							<b>bar (psig)</b>
12	SS-TTW-S12MM <sup>①</sup>	77.7 (3.06)	38.9 (1.53)	72.7 (2.86)	9.5 (0.73)	337 (4900)	
16	SS-TTW-S16MM <sup>①</sup>				12.7 (0.50)		
18	SS-TTW-S18MM	89.4 (3.52)	44.7 (1.76)	75.2 (2.96)	15.0 (0.59)	316 (4600)	

① To order an angle-pattern Thermowell Tee, add -A to the ordering number.

Example: SS-TTW-S6-A

Refer to *Temperature Measurement Devices, Bimetal Thermometers and Thermowells* catalog, MS-02-353, for additional information.

**3 Extended Male Connector**

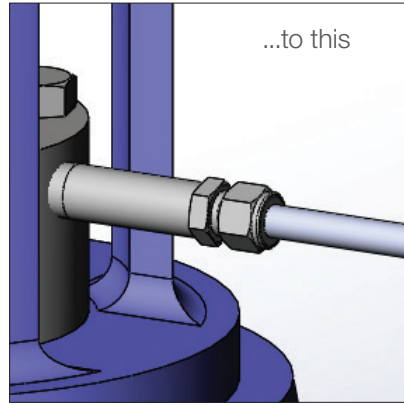
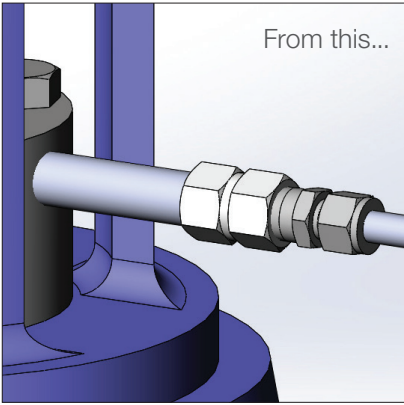

Eliminate threaded pipe and potential leak points with a single fitting. Available in 4- and 6- inch lengths, to allow you to clear the shroud and go straight from the gland to your tubing run in one piece.



**Extended Male Connector Hex Shank Ordering Information**

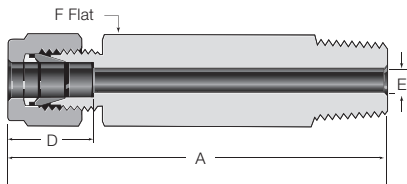

Tube OD	NPT Size	Ordering Number	Dimensions				Pressure Rating
			A	D	E	F	
<b>Dimensions, in. (mm)</b>							psig (bar)
3/8	3/8	SS-600-1-6-50553	4.00 (102)	0.66 (16.8)	0.28 (7.1)	11/16	7500 (516)
		SS-600-1-6-49485	6.00 (152)				
1/2	1/2	SS-810-1-8-50553	4.00 (102)	0.90 (22.9)	0.41 (10.4)	7/8	6700 (461)
		SS-810-1-8-49485	6.00 (152)				
3/4	1/2	SS-1210-1-8-50553	4.00 (102)	0.96 (24.4)	0.63 (16.0)	1 1/16	5800 (399)
		SS-1210-1-8-49485	6.00 (152)				
	3/4	SS-1210-1-12-50553	4.00 (102)				
		SS-1210-1-12-49485	6.00 (152)				
<b>Dimensions, mm (in.)</b>							bar (psig)
12	1/2	SS-12M0-1-8-50553	102 (4.00)	22.8 (0.90)	9.5 (0.37)	22	470 (6821)
		SS-12M0-1-8-49485	152 (6.00)				

**Extended Male Connector Machined Shank Ordering Information**

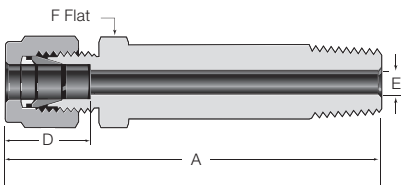

Tube OD	NPT Size	Ordering Number	Dimensions				Pressure Rating
			A	D	E	F	
<b>Dimensions, in. (mm)</b>							psig (bar)
3/8	3/8	SS-600-1-6-52166	4.00 (102)	0.66 (16.8)	0.28 (7.1)	11/16	7500 (516)
		SS-600-1-6-52167	6.00 (152)				
1/2	1/2	SS-810-1-6-52166	4.00 (102)	0.90 (22.9)	0.41 (10.4)	7/8	6700 (461)
		SS-810-1-6-52167	6.00 (152)				
3/4	1/2	SS-810-1-8-52166	4.00 (102)	0.96 (24.4)	0.63 (16.0)	1 1/16	5800 (399)
		SS-810-1-8-52167	6.00 (152)				
	3/4	SS-1210-1-12-52166	4.00 (102)				
		SS-1210-1-12-52167	6.00 (152)				
<b>Dimensions, mm (in.)</b>							bar (psig)
12	1/2	SS-12M0-1-8-52166	102 (4.00)	22.8 (0.90)	9.5 (0.37)	22	470 (6821)
		SS-12M0-1-8-52167	152 (6.00)				
18	3/4	SS-18M0-1-12-52166	102 (4.00)	24.4 (0.96)	11.9 (0.47)	27	370 (5370)
		SS-18M0-1-12-52167	152 (6.00)				

**4 Orifice Union**

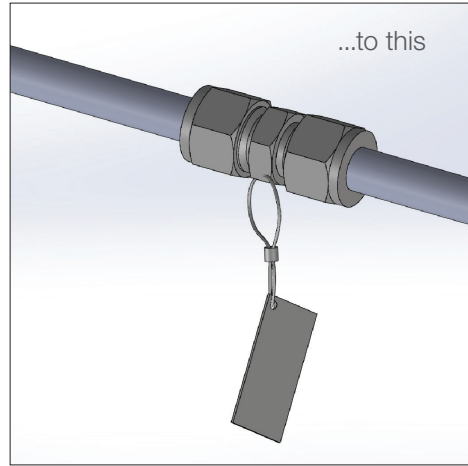
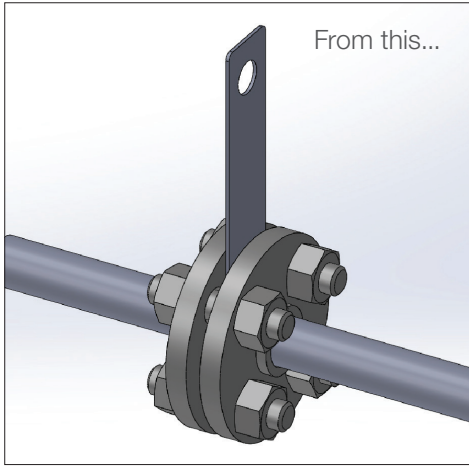

Easily add an orifice to a flush system with the orifice union. This fitting makes welding bulky flange assemblies unnecessary. Tagged for visual identification.



**Orifice Union Adapter with Lanyard**

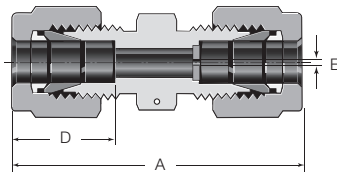

Tube OD	Ordering Number	Dimensions			Pressure Rating
		A	D	E	
Dimensions, in. (mm)					psig (bar)
1/2	SS-810-6PD-50174	2.02 (51.3)	0.90 (22.9)	0.125 (3.2)	6700 (461)
3/4	SS-1210-6PD-50174	2.11 (53.6)	0.96 (24.2)		5800 (399)

Please include E-dimension at time of order. E-dimension will be between 0.125 in. (0.3 mm) and maximum E-dimension for size of tube fitting.

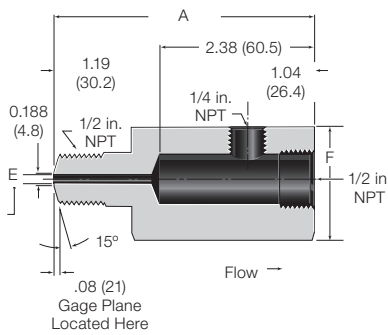

**Orifice Adapter**

Tube OD	Female NPT	Ordering Number	Dimensions			Pressure Rating
			A	E	F	
Dimensions, in. (mm)						psig (bar)
1/2	1/2	SS-8-A-08097	4.00 (102)	0.125 (3.2)	1 5/8	4900 (337)
3/4		SS-12-R8-8-08096			1 1/16	

## Process Side Plans

### API Plan 11 Flush

API Plan 11 recirculates flow from a high-pressure section of the pump, typically the discharge piping, through a flow control orifice to the seal. Plan 11 is the default flush plan for most pumps.

Plan 11

- Removes heat from the seal chamber
- Ensures proper pressure in the seal chamber in order to prevent pumped fluid from vaporizing
- Allows seal chamber to be self-venting when used with horizontal pumps

Plan 11 is available as a kit of components ready for field assembly.

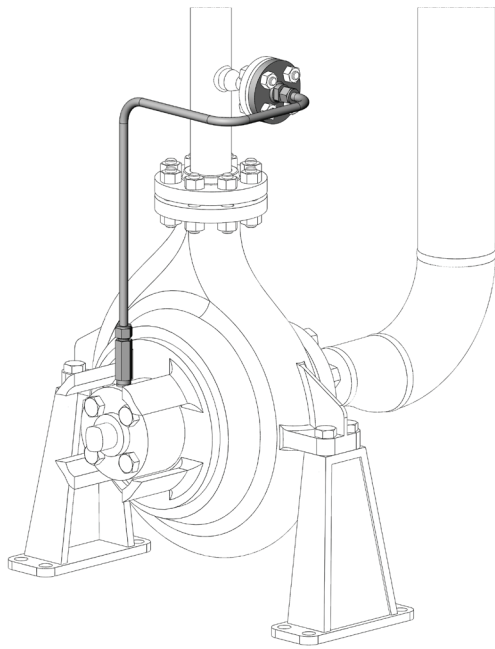

**Fig. 2 API Plan 11**

Kit components shown solid and include some optional components.

*Kit contents may include:*

- Swagelok tube fittings
- Flange adapters
- Pipe fittings
- V series 2-valve manifold
- Bimetal thermometer
- TTW series thermowell tee
- PGI series gauges
- Tubing
- Pressure transmitter
- Pipe nipple

See page 83 for additional information on individual components.

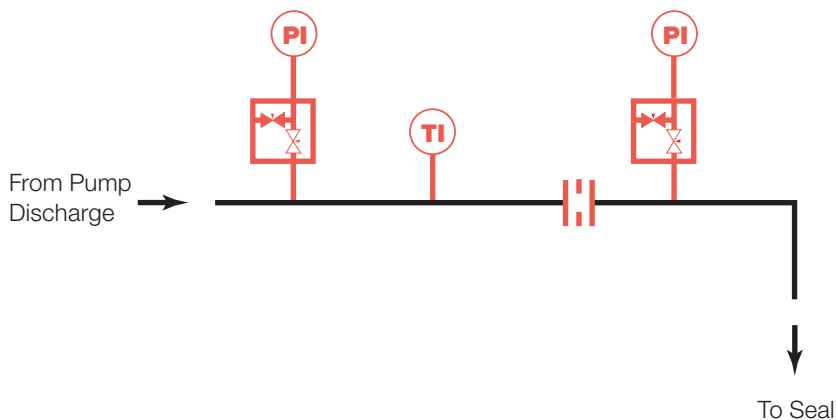

**Fig. 3 API Plan 11 P&ID**

Optional components shown in red.

Contact your authorized Swagelok sales and service center for information on optional components.

**API Plan 11 continued****Ordering Information**

Build an ordering number by combining the designators in the sequence shown below.

**Plan 11 Kit**

SPK11 - **1** - **2** **3** **4** **5** **6** **7**  
**C** - **C** **4** **1** - **C** **1** **1**

**1 Primary Tubing Size**

**C** = 1/2 in.  
**K** = 12 mm

**2 Seal Connection (Flush)**

**B** = 3/8 in. female NPT  
**C** = 1/2 in. female NPT  
**D** = 3/4 in. female NPT  
**H** = G 3/8  
**J** = G 1/2  
**K** = G 3/4

**3 Seal Connector Type (Flush)**

**1** = Standard female connector<sup>①</sup>  
**2** = Standard male connector  
**3** = 4 in. extended male connector, hex  
**4** = 6 in. extended male connector, hex  
**5** = 4 in. extended male connector, machined  
**6** = 6 in. extended male connector, machined

<sup>①</sup> Installation will require use of pipe nipple (included in kit when female connector selected).

**4 Seal Connection Instrumentation (Flush)**

**1** = None  
**2** = Pressure gauge  
**3** = Pressure transmitter

**5 Pump Discharge Connector Type**

**C** = 1/2 in. female NPT  
**D** = 3/4 in. female NPT  
**M** = 1/2 in. Class 150 ANSI flange  
**N** = 1/2 in. Class 300 ANSI flange  
**P** = 3/4 in. Class 150 ANSI flange  
**Q** = 3/4 in. Class 300 ANSI flange

**6 Pump Discharge Instrumentation**

**1** = None  
**2** = Pressure gauge  
**3** = Pressure transmitter  
**4** = Thermometer  
**5** = Pressure gauge and thermometer  
**6** = Pressure transmitter and thermometer

**7 Flow Control Orifice**

**1** = None  
**2** = Tube fitting union  
**3** = Integral to flange adapter<sup>①</sup>  
**4** = Orifice plate<sup>①</sup>

<sup>①</sup> Not compatible with pump discharge instrumentation pressure gauge or pressure transmitter. Must select an ANSI flange pump discharge connector with this option.



## API Plan 12 Flush with Strainer

API Plan 12 recirculates flow from a high-pressure section of the pump, typically the discharge piping, through a flow control orifice to the seal. In order to remove particulate in the flush stream and prevent clogging, flow passes through a strainer placed prior to the flow control orifice. The addition of pressure gauges on either side of the strainer allows the strainer to be monitored for servicing.

Plan 12

- Prevents orifice clogging through the addition of a strainer
- Removes heat and flushes particulate from the seal chamber
- Ensures proper pressure in the seal chamber to prevent pumped fluid from vaporizing
- Allows the seal chamber to be self-venting when used with horizontal pumps

Plan 12 is available as a kit of components ready for field assembly.

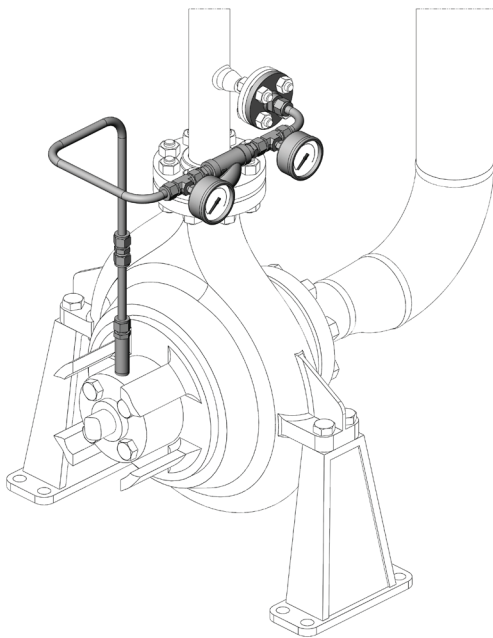

**Fig. 4 API Plan 12**

Kit components shown solid and include some optional components.

*Kit contents may include:*

- Swagelok tube fittings
- Flange adapters
- Pipe fittings
- V series 2-valve manifold
- Bimetal thermometer
- TTW series thermowell tee
- PGI series gauges
- Tubing Pressure transmitter
- Pipe nipple
- Y strainer

See page 83 for additional information on individual components.

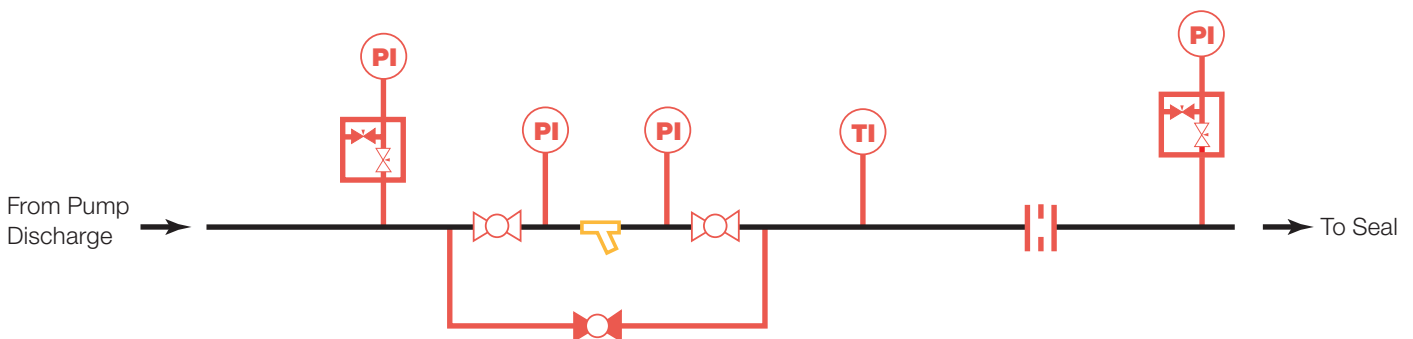

**Fig. 5 API Plan 12 P&ID**

Optional components shown in red.

Contact your authorized Swagelok sales and service center for information on optional components.

**API Plan 12 continued****Ordering Information**

Build an ordering number by combining the designators in the sequence shown below.

**Plan 12 Kit**

SPK12 - **1** - **2** **3** **4** **5** **6** **7** **8**  
**C** - **C** **4** **1** - **C** **1** **B** - **A**

**1 Primary Tubing Size**

**C** = 1/2 in.  
**K** = 12 mm

**2 Seal Connection (Flush)**

**B** = 3/8 in. female NPT  
**C** = 1/2 in. female NPT  
**D** = 3/4 in. female NPT  
**H** = G 3/8  
**J** = G 1/2  
**K** = G 3/4

**3 Seal Connector Type (Flush)**

**1** = Standard female connector<sup>①</sup>  
**2** = Standard male connector  
**3** = 4 in. extended male connector, hex  
**4** = 6 in. extended male connector, hex  
**5** = 4 in. extended male connector, machined  
**6** = 6 in. extended male connector, machined

<sup>①</sup> Installation will require use of pipe nipple (included in kit when female connector selected).

**4 Seal Connection Instrumentation (Flush)**

**1** = None  
**2** = Pressure gauge  
**3** = Pressure transmitter

**5 Pump Discharge Connector Type**

**C** = 1/2 in. female NPT  
**D** = 3/4 in. female NPT  
**M** = 1/2 in. Class 150 ANSI flange  
**N** = 1/2 in. Class 300 ANSI flange  
**P** = 3/4 in. Class 150 ANSI flange  
**Q** = 3/4 in. Class 300 ANSI flange

**6 Pump Discharge Instrumentation**

**1** = None  
**2** = Pressure gauge  
**3** = Pressure transmitter  
**4** = Thermometer  
**5** = Pressure gauge and thermometer  
**6** = Pressure transmitter and thermometer

**7 Pump Discharge Orifice**

**1** = None  
**2** = Tube fitting union

**8 Filtration**

**A** = Filter only  
**C** = Manual bypass valves  
**D** = Inlet/outlet gauges  
**G** = Manual bypass valves with inlet/outlet gauges

## API Plan 13 Flush, from Chamber to Suction

API Plan 13 recirculates flow from the seal chamber to the suction side of the pump. This plan is common for vertical pumps.

### Plan 13

- Removes heat and flushes particulate from the seal chamber
- Allows the seal chamber to be self-venting when used with horizontal pumps

Plan 13 is available as a kit of components ready for field assembly.

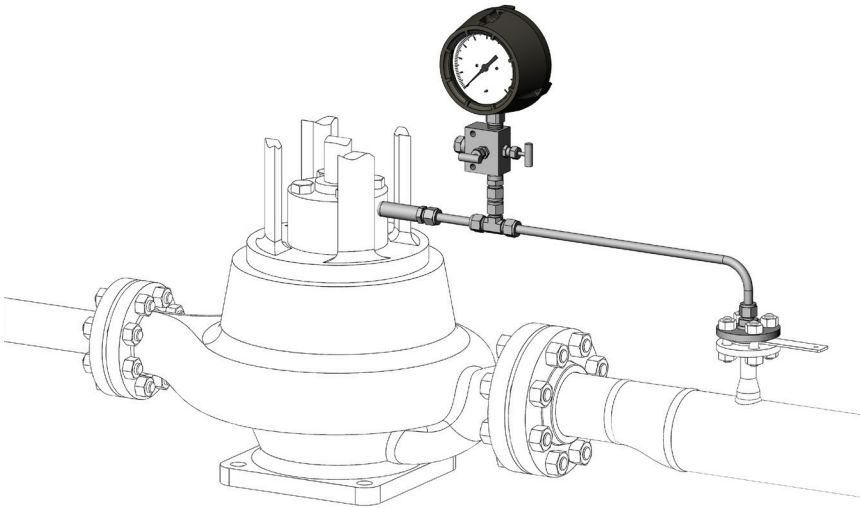

**Fig. 6 API Plan 13**

Kit components shown solid and include some optional components.

*Kit contents may include:*

- Swagelok tube fittings
- Flange adapters
- Pipe fittings
- V series 2-valve manifold
- Bimetal thermometer
- TTW series thermowell tee
- PGI series gauges
- Tubing
- Pressure transmitter
- Pipe nipple

See page 83 for additional information on individual components.

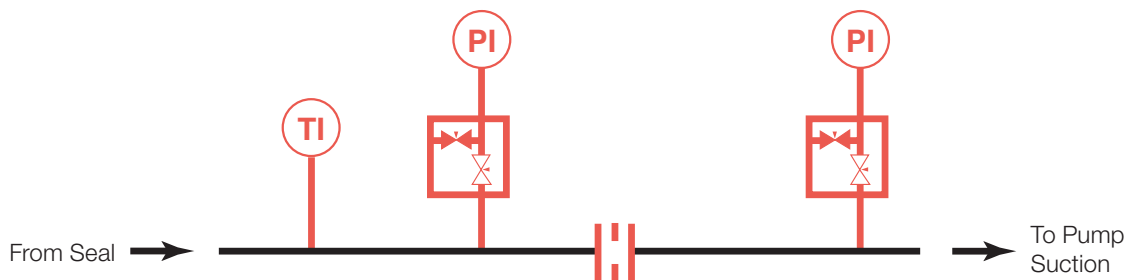

**Fig. 7 API Plan 13 P&ID**

Optional components shown in red.

Contact your authorized Swagelok sales and service center for information on optional components.

**API Plan 13 continued****Ordering Information**

Build an ordering number by combining the designators in the sequence shown below.

**Plan 13 Kit**

SPK13 - **1** - **2** **3** **4** **1** - **5** **6** **7**  
**C** - **C** **4** **1** - **C** **1** **1**

**1 Primary Tubing Size**

- C** = 1/2 in.
- K** = 12 mm

**2 Seal Connection (Flush)**

- B** = 3/8 in. female NPT
- C** = 1/2 in. female NPT
- D** = 3/4 in. female NPT
- H** = G 3/8
- J** = G 1/2
- K** = G 3/4

**3 Seal Connector Type (Flush)**

- 1** = Standard female connector<sup>①</sup>
- 2** = Standard male connector
- 3** = 4 in. extended male connector, hex
- 4** = 6 in. extended male connector, hex
- 5** = 4 in. extended male connector, machined
- 6** = 6 in. extended male connector, machined

<sup>①</sup> Installation will require use of pipe nipple (included in kit when female connector selected).

**4 Seal Connection Instrumentation (Flush)**

- 1** = None
- 2** = Pressure gauge
- 3** = Pressure transmitter
- 4** = Thermometer
- 5** = Pressure gauge and thermometer
- 6** = Pressure transmitter and thermometer

**5 Pump Suction Connector Type**

- C** = 1/2 in. female NPT
- D** = 3/4 in. female NPT
- M** = 1/2 in. Class 150 ANSI flange
- N** = 1/2 in. Class 300 ANSI flange
- P** = 3/4 in. Class 150 ANSI flange
- Q** = 3/4 in. Class 300 ANSI flange

**6 Pump Suction Instrumentation**

- 1** = None
- 2** = Pressure gauge
- 3** = Pressure transmitter

**7 Pump Suction Orifice**

- 1** = None
- 2** = Tube fitting union
- 3** = Integral to flange adapter<sup>①</sup>
- 4** = Orifice plate<sup>①</sup>

<sup>①</sup> Not compatible with pump suction instrumentation pressure gauge or pressure transmitter. Must select an ANSI flange pump suction connector with this option.

## API Plan 14 Flush, Combination of Plans 11 and 13

API Plan 14 combines Plan 11 and Plan 13. Flow is recirculated from the pump discharge into the seal chamber and from the seal chamber to the pump suction. Fluid flow is increased since the seal chamber is continuously vented, leading to higher cooling capacity.

### Plan 14

- Removes heat and flushes particulate from the seal chamber
- Controls seal chamber pressure on vertical pumps

Plan 14 is available as a kit of components ready for field assembly.

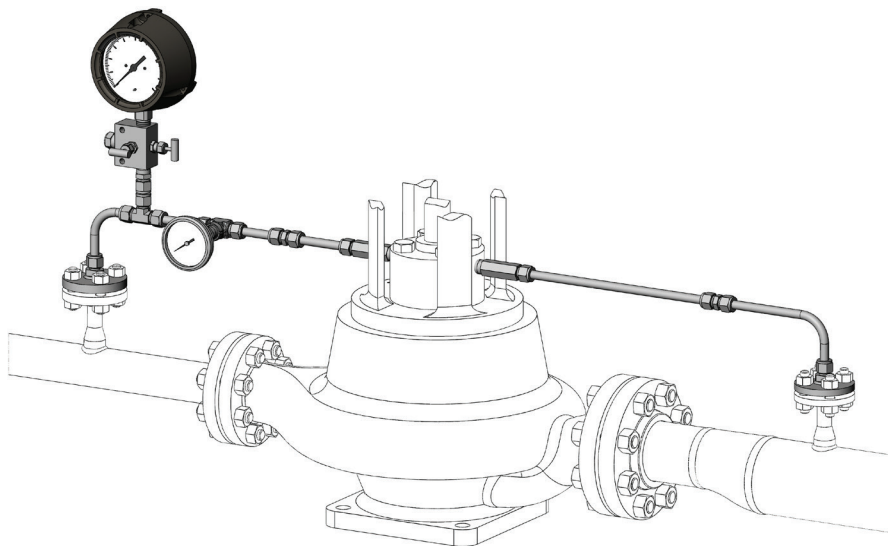

**Fig. 8 API Plan 14**

Kit components shown solid and include some optional components.

*Kit contents may include:*

- Swagelok tube fittings
- Flange adapters
- Pipe fittings
- V series 2-valve manifold
- Bimetal thermometer
- TTW series thermowell tee
- PGI series gauges
- Tubing
- Pressure transmitter
- Pipe nipple

See page 83 for additional information on individual components.



**Fig. 9 API Plan 14 P&ID**

Optional components shown in red.

Contact your authorized Swagelok sales and service center for information on optional components.

## API Plan 14 continued

## Ordering Information

Build an ordering number by combining the designators in the sequence shown below.

## Plan 14 Kit

SPK14 - **1** - **2** **3** - **4** **5** **6** - **7** **8** **9** - **10** **11** **12**

**C** - **C** **4** - **C** **4** **1** - **C** **1** **2** - **C** **1** **2**

**1 Primary Tubing Size**

- C** = 1/2 in.
- K** = 12 mm

**2 Seal Connection (Flush Inlet)**

- B** = 3/8 in. female NPT
- C** = 1/2 in. female NPT
- D** = 3/4 in. female NPT
- H** = G 3/8
- J** = G 1/2
- K** = G 3/4

**3 Seal Connector Type (Flush Inlet)**

- 1** = Standard female connector<sup>①</sup>
- 2** = Standard male connector
- 3** = 4 in. extended male connector, hex
- 4** = 6 in. extended male connector, hex
- 5** = 4 in. extended male connector, machined
- 6** = 6 in. extended male connector, machined

<sup>①</sup> Installation will require use of pipe nipple (included in kit when female connector selected).

**4 Seal Connection (Flush Outlet)**

- B** = 3/8 in. female NPT
- C** = 1/2 in. female NPT
- D** = 3/4 in. female NPT
- H** = G 3/8
- J** = G 1/2
- K** = G 3/4

**5 Seal Connector Type (Flush Outlet)**

- 1** = Standard female connector<sup>①</sup>
- 2** = Standard male connector
- 3** = 4 in. extended male connector, hex
- 4** = 6 in. extended male connector, hex
- 5** = 4 in. extended male connector, machined
- 6** = 6 in. extended male connector, machined

<sup>①</sup> Installation will require use of pipe nipple (included in kit when female connector selected).

**6 Seal Connection Instrumentation (Flush Outlet)**

- 1** = None
- 2** = Pressure gauge
- 3** = Pressure transmitter
- 4** = Thermometer
- 5** = Pressure gauge and thermometer
- 6** = Pressure transmitter and thermometer

**7 Pump Discharge Connector Type**

- C** = 1/2 in. female NPT
- D** = 3/4 in. female NPT
- M** = 1/2 in. Class 150 ANSI flange
- N** = 1/2 in. Class 300 ANSI flange
- P** = 3/4 in. Class 150 ANSI flange
- Q** = 3/4 in. Class 300 ANSI flange

**8 Pump Discharge Instrumentation**

- 1** = None
- 2** = Pressure gauge
- 3** = Pressure transmitter
- 4** = Thermometer
- 5** = Pressure gauge and thermometer
- 6** = Pressure transmitter and thermometer

**9 Flow Control Orifice (from discharge)**

- 1** = None
- 2** = Tube fitting union
- 3** = Integral to flange adapter<sup>①</sup>
- 4** = Orifice plate<sup>①</sup>

<sup>①</sup> Not compatible with pump suction instrumentation pressure gauge or pressure transmitter. Must select an ANSI flange pump suction connector with this option.

**10 Pump Suction Connector Type**

- C** = 1/2 in. female NPT
- D** = 3/4 in. female NPT
- M** = 1/2 in. Class 150 ANSI flange
- N** = 1/2 in. Class 300 ANSI flange
- P** = 3/4 in. Class 150 ANSI flange
- Q** = 3/4 in. Class 300 ANSI flange

**11 Pump Suction Instrumentation**

- 1** = None
- 2** = Pressure gauge
- 3** = Pressure transmitter
- 4** = Thermometer
- 5** = Pressure gauge and thermometer
- 6** = Pressure transmitter and thermometer

**12 Flow Control Orifice (to suction)**

- 1** = None
- 2** = Tube fitting union
- 3** = Integral to flange adapter<sup>①</sup>
- 4** = Orifice plate<sup>①</sup>

<sup>①</sup> Not compatible with pump suction instrumentation pressure gauge or pressure transmitter. Must select an ANSI flange pump suction connector with this option.

## API Plan 21 Cooled Flush

API Plan 21 adds a cooler to Plan 11 for applications requiring better control of flush vapor margin. Flow is routed from the discharge side of the pump through an orifice and a cooler before being returned to the seal chamber.

Plan 21

- Provides cooled flush fluid to the process side of the seal
- Removes heat and flushes particulate from the seal chamber
- Improves fluid vapor margin in the seal chamber

Plan 21 is available as a kit of components ready for field assembly.

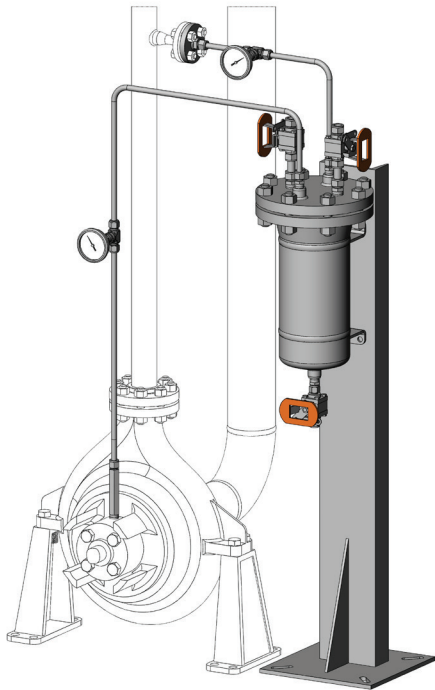

**Fig. 10 API Plan 21**

Kit components shown solid and include some optional components.

Kit contents may include:

- Swagelok tube fittings
- Flange adapters
- Pipe fittings
- V series 2-valve manifold
- 63 series ball valve
- Bimetal thermometer
- TTW series thermowell tee
- PGI series gauges
- Tubing
- Pressure transmitter
- Heat exchanger
- Heat exchanger stand
- Pipe nipple

See page 83 for additional information on individual components.

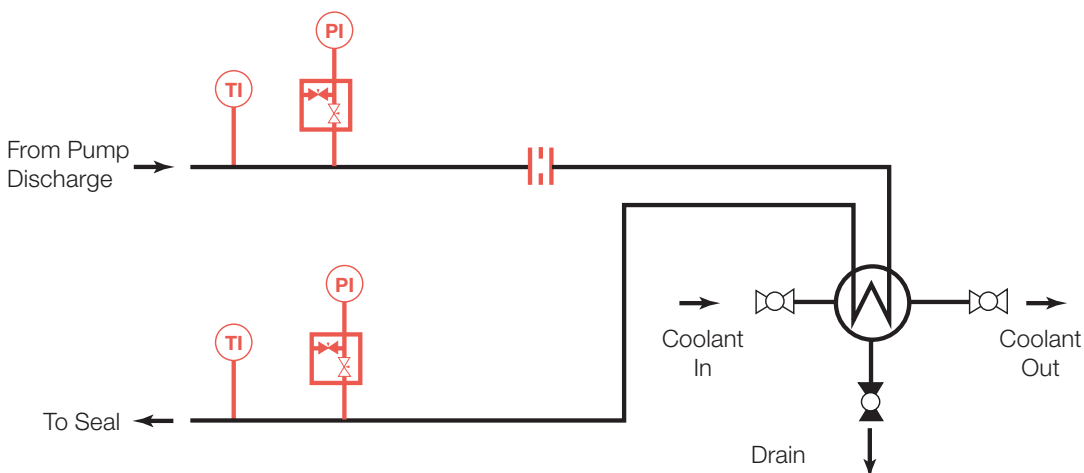

**Fig. 11 API Plan 21 P&ID**

Optional components shown in red.

Contact your authorized Swagelok sales and service center for information on optional components.

**API Plan 21 continued****Ordering Information**

Build an ordering number by combining the designators in the sequence shown below.

**Plan 21 Kit**

SPK21 - **1** - **2** **3** **4** **1** - **5** **6** **7**  
**C** - **C** **4** **1** - **C** **1** **1**

**1 Primary Tubing Size**

**C** = 1/2 in.  
**K** = 12 mm

**2 Seal Connection (Flush)**

**B** = 3/8 in. female NPT  
**C** = 1/2 in. female NPT  
**D** = 3/4 in. female NPT  
**H** = G 3/8  
**J** = G 1/2  
**K** = G 3/4

**3 Seal Connector Type (Flush)**

**1** = Standard female connector<sup>①</sup>  
**2** = Standard male connector  
**3** = 4 in. extended male connector, hex  
**4** = 6 in. extended male connector, hex  
**5** = 4 in. extended male connector, machined  
**6** = 6 in. extended male connector, machined  
<sup>①</sup> Installation will require use of pipe nipple (included in kit when female connector selected).

**4 Seal Connection Instrumentation (Flush)**

**1** = None  
**2** = Pressure gauge  
**3** = Pressure transmitter  
**4** = Thermometer  
**5** = Pressure gauge and thermometer  
**6** = Pressure transmitter and thermometer

**5 Pump Discharge Connector Type**

**C** = 1/2 in. female NPT  
**D** = 3/4 in. female NPT  
**M** = 1/2 in. Class 150 ANSI flange  
**N** = 1/2 in. Class 300 ANSI flange  
**P** = 3/4 in. Class 150 ANSI flange  
**Q** = 3/4 in. Class 300 ANSI flange

**6 Pump Discharge Instrumentation**

**1** = None  
**2** = Pressure gauge  
**3** = Pressure transmitter  
**4** = Thermometer  
**5** = Pressure gauge and thermometer  
**6** = Pressure transmitter and thermometer

**7 Pump Discharge Orifice**

**1** = None  
**2** = Tube fitting union  
**3** = Integral to flange adapter<sup>①</sup>  
**4** = Orifice plate<sup>①</sup>

<sup>①</sup> Not compatible with pump discharge instrumentation pressure gauge or pressure transmitter. Must select an ANSI flange pump discharge connector with this option.



## API Plan 22 Cooled Flush with Strainer

API Plan 22 adds a strainer to Plan 21. Flow is routed from the discharge side of the pump, through a strainer, an orifice, and a cooler before being returned to the seal chamber. The addition of pressure gauges on either side of the strainer allows the strainer to be monitored for servicing. In dry climates, air-cooled tubing arrangements are preferred to reduce common issues associated with water cooled systems.

### Plan 22

- Prevents orifice clogging through the addition of a strainer
- Provides cooled flush fluid to the process side of the seal
- Removes heat and flushes particulate from the seal chamber
- Improves vapor pressure margin in the seal chamber

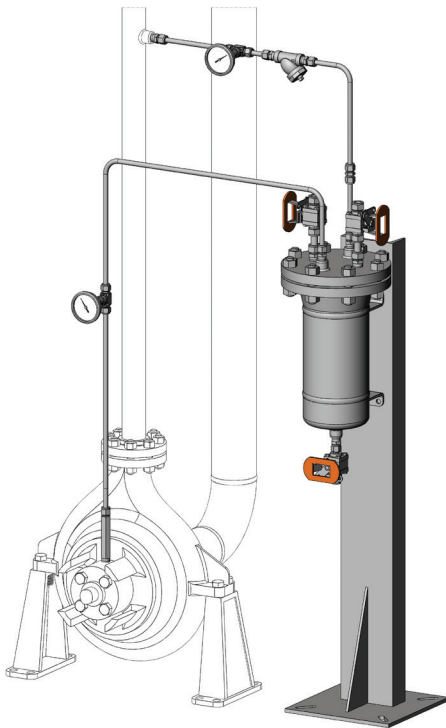

**Fig. 12 API Plan 22**

Kit components shown solid and include some optional components.

Plan 22 is available as a kit of components ready for field assembly.

*Kit contents may include:*

- Swagelok tube fittings
- Flange adapters
- Pipe fittings
- V series 2-valve manifold
- 63 series ball valve
- Bimetal thermometer
- TTW series thermowell tee
- PGI series gauges
- Tubing
- Pressure transmitter
- Heat exchanger
- Heat exchanger stand
- Y strainer
- Pipe nipple

See page 83 for additional information on individual components.

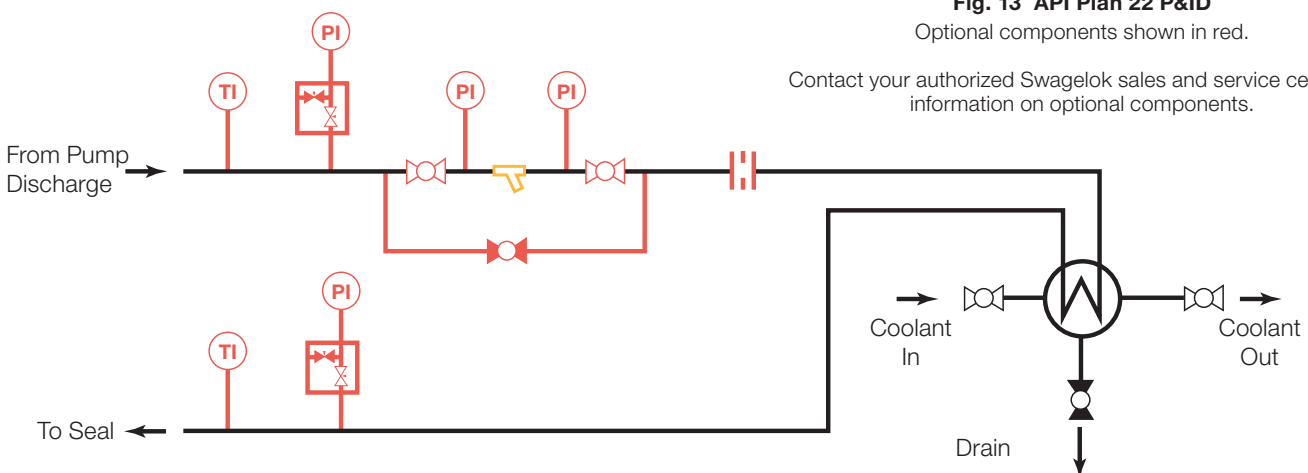

**Fig. 13 API Plan 22 P&ID**

Optional components shown in red.

Contact your authorized Swagelok sales and service center for information on optional components.

**API Plan 22 continued****Ordering Information**

Build an ordering number by combining the designators in the sequence shown below.

**Plan 22 Kit**

SPK22 - **1** - **2** **3** **4** **5** **6** **7** - **8**  
 C - C 4 1 - C 1 2 - C

**1 Primary Tubing Size**

C = 1/2 in.  
 K = 12 mm

**2 Seal Connection (Flush)**

B = 3/8 in. female NPT  
 C = 1/2 in. female NPT  
 D = 3/4 in. female NPT  
 H = G 3/8  
 J = G 1/2  
 K = G 3/4

**3 Seal Connector Type (Flush)**

1 = Standard female connector<sup>①</sup>  
 2 = Standard male connector  
 3 = 4 in. extended male connector, hex  
 4 = 6 in. extended male connector, hex  
 5 = 4 in. extended male connector, machined  
 6 = 6 in. extended male connector, machined

<sup>①</sup> Installation will require use of pipe nipple (included in kit when female connector selected).

**4 Seal Connection Instrumentation (Flush)**

1 = None  
 2 = Pressure gauge  
 3 = Pressure transmitter  
 4 = Thermometer  
 5 = Pressure gauge and thermometer  
 6 = Pressure transmitter and thermometer

**5 Pump Discharge Connector Type**

C = 1/2 in. female NPT  
 D = 3/4 in. female NPT  
 M = 1/2 in. Class 150 ANSI flange  
 N = 1/2 in. Class 300 ANSI flange  
 P = 3/4 in. Class 150 ANSI flange  
 Q = 3/4 in. Class 300 ANSI flange

**6 Pump Discharge Instrumentation**

1 = None  
 2 = Pressure gauge  
 3 = Pressure transmitter  
 4 = Thermometer  
 5 = Pressure gauge and thermometer  
 6 = Pressure transmitter and thermometer

**7 Pump Discharge Orifice**

1 = None  
 2 = Tube fitting union

**8 Filtration**

A = Filter only  
 C = Manual bypass valves  
 D = Inlet/outlet gauges  
 G = Manual bypass valves with inlet/outlet gauges

## API Plan 23 Cooled Flush, Recirculated through Seal Chamber

API Plan 23 utilizes a circulation device, typically a pumping ring, to route the fluid from the seal chamber through a cooler before returning the cooled fluid to the seal chamber. A throat bushing isolates the cooled seal chamber flush fluid from the hotter pumped liquid.

Plan 23

- Provides an isolated cooled flush fluid in the seal chamber
- Reduces cooler duty due to isolated flush fluid, extending the life of the close-clearance throat bushing

Plan 23 is available as a kit of components ready for field assembly.

Kit contents may include:

- Swagelok tube fittings
- Pipe fittings
- V series 2-valve manifold
- 63 series ball valves
- Bimetal thermometer
- TTW series thermowell tee
- PGI series gauges
- Tubing Pressure transmitter
- Heat exchanger
- Heat exchanger stand
- Pipe nipple

See page 83 for additional information on individual components.

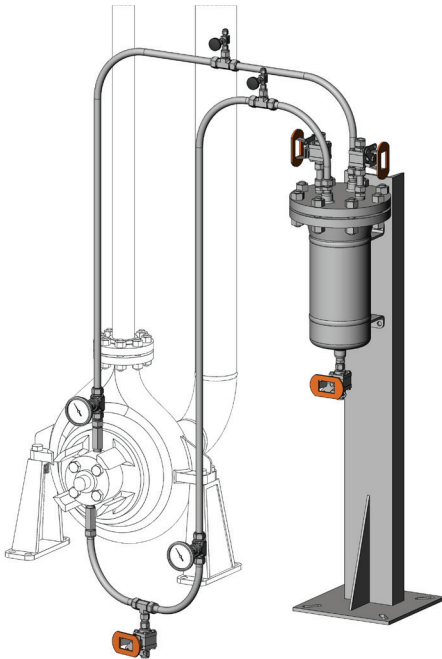

**Fig. 14 API Plan 23**

Kit components shown solid and include some optional components.

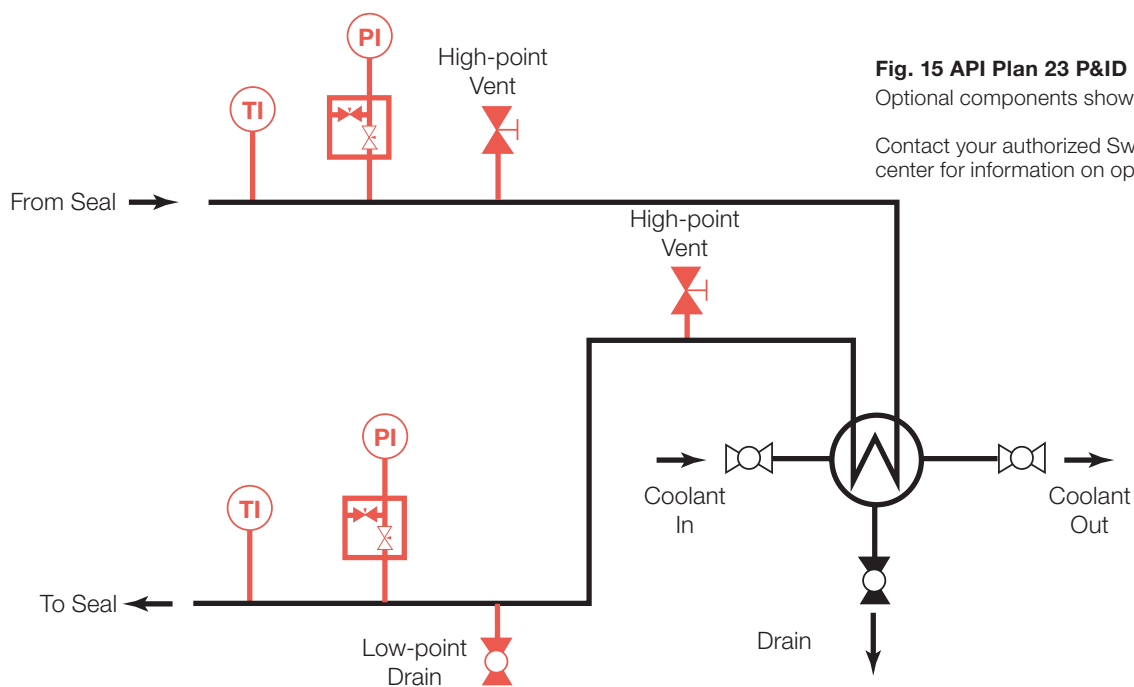

**Fig. 15 API Plan 23 P&ID**

Optional components shown in red.

Contact your authorized Swagelok sales and service center for information on optional components.

**API Plan 23 continued****Ordering Information**

Build an ordering number by combining the designators in the sequence shown below.

**Plan 23 Kit**

SPK23 - **1** - **2** **3** **4** **5** - **6** **7** **8** **9**  
**D** - **C** **4** **4** **D** - **C** **4** **1** **B**

**1 Primary Tubing Size**

**C** = 3/4 in.  
**K** = 18 mm

**2 Seal Connection (Flush Inlet)**

**B** = 3/8 in. female NPT  
**C** = 1/2 in. female NPT  
**D** = 3/4 in. female NPT  
**H** = G 3/8  
**J** = G 1/2  
**K** = G 3/4

**3 Seal Connector Type (Flush Inlet)**

**1** = Standard female connector<sup>①</sup>  
**2** = Standard male connector  
**3** = 4 in. extended male connector, hex  
**4** = 6 in. extended male connector, hex  
**5** = 4 in. extended male connector, machined  
**6** = 6 in. extended male connector, machined

<sup>①</sup> Installation will require use of pipe nipple (included in kit when female connector selected).

**4 Seal Connection Instrumentation (Flush Inlet)**

**1** = None  
**2** = Pressure gauge  
**3** = Pressure transmitter  
**4** = Thermometer  
**5** = Pressure gauge and thermometer  
**6** = Pressure transmitter and thermometer

**5 Seal Connection Vents/Drains (Flush Inlet)**

**A** = None  
**B** = High-point vent  
**C** = Low-point drain  
**D** = High-point vent and low-point drain

**6 Seal Connection (Flush Outlet)**

**B** = 3/8 in. female NPT  
**C** = 1/2 in. female NPT  
**D** = 3/4 in. female NPT  
**H** = G 3/8  
**J** = G 1/2  
**K** = G 3/4

**7 Seal Connector Type (Flush Outlet)**

**1** = Standard female connector<sup>①</sup>  
**2** = Standard male connector  
**3** = 4 in. extended male connector, hex  
**4** = 6 in. extended male connector, hex  
**5** = 4 in. extended male connector, machined  
**6** = 6 in. extended male connector, machined

<sup>①</sup> Installation will require use of pipe nipple (included in kit when female connector selected).

**8 Seal Connection Instrumentation (Flush Outlet)**

**1** = None  
**2** = Pressure gauge  
**3** = Pressure transmitter  
**4** = Thermometer  
**5** = Pressure gauge and thermometer  
**6** = Pressure transmitter and thermometer

**9 Seal Connection Vents/Drains (Flush Outlet)**

**A** = None  
**B** = High-point vent

## API Plan 31 Flush with Cyclone Separator

API Plan 31 is used to remove solids from the flush stream by incorporating a cyclone separator into the flush tubing. Flow is routed from the discharge side of the pump through the cyclone separator. Clean flush fluid leaving the separator is routed to the seal chamber while fluid containing the solids is routed back into the suction side of the pump. In order for Plan 31 to be effective, it is recommended that the specific gravity of the solids be at least twice the specific gravity of the flush fluid.

### Plan 31

- Removes heat from the seal chamber
- Ensures proper pressure in the seal chamber in order to prevent pumped fluid from vaporizing
- Allows seal chamber to be self-venting when used with horizontal pumps
- Removes solids from the flush fluid

Plan 31 is available as a kit of components ready for field assembly.

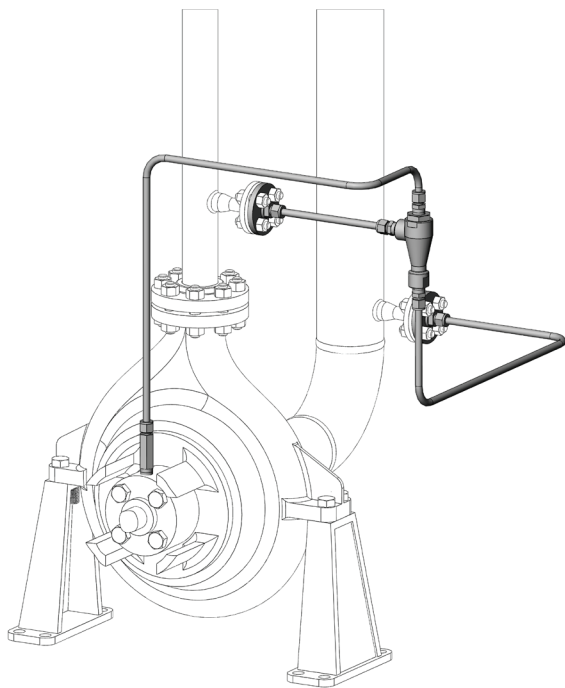

**Fig. 16 API Plan 31**

Kit components shown solid and include some optional components.

Kit contents may include:

- Swagelok tube fittings
- Flange adapters
- Pipe fittings
- V series 2-valve manifold
- Bimetal thermometer
- TTW series thermowell tee
- PGI series gauges
- Tubing
- Pressure transmitter
- Cyclone separator
- Pipe nipple

See page 83 for additional information on individual components.

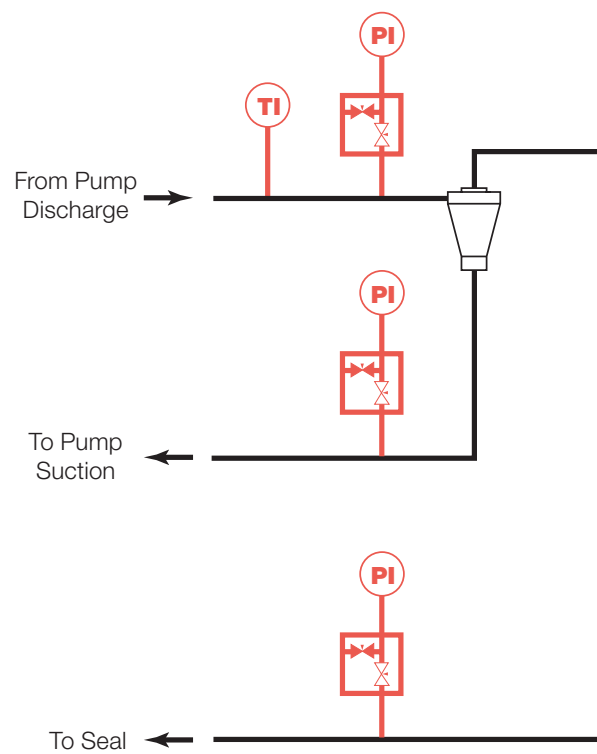

**Fig. 17 API Plan 31 P&ID**

Optional components shown in red.

Contact your authorized Swagelok sales and service center for information on optional components.

**API Plan 31 continued****Ordering Information**

Build an ordering number by combining the designators in the sequence shown below.

**Plan 31 Kit**

SPK31 - **1** - **2** **3** **4** - **5** **6** - **7** **8**

**C** - **C** **4** **1** - **C** **1** - **C** **2**

**1 Primary Tubing Size**

**C** = 1/2 in.  
**K** = 12 mm

**2 Seal Connection (Flush)**

**B** = 3/8 in. female NPT  
**C** = 1/2 in. female NPT  
**D** = 3/4 in. female NPT  
**H** = G 3/8  
**J** = G 1/2  
**K** = G 3/4

**3 Seal Connector Type (Flush)**

**1** = Standard female connector<sup>①</sup>  
**2** = Standard male connector  
**3** = 4 in. extended male connector, hex  
**4** = 6 in. extended male connector, hex  
**5** = 4 in. extended male connector, machined  
**6** = 6 in. extended male connector, machined  
<sup>①</sup> Installation will require use of pipe nipple (included in kit when female connector selected).

**4 Seal Connection Instrumentation (Flush)**

**1** = None  
**2** = Pressure gauge  
**3** = Pressure transmitter  
**4** = Thermometer  
**5** = Pressure gauge and thermometer  
**6** = Pressure transmitter and thermometer

**5 Pump Discharge Connector Type**

**C** = 1/2 in. female NPT  
**D** = 3/4 in. female NPT  
**M** = 1/2 in. Class 150 ANSI flange  
**N** = 1/2 in. Class 300 ANSI flange  
**P** = 3/4 in. Class 150 ANSI flange  
**Q** = 3/4 in. Class 300 ANSI flange

**6 Pump Discharge Instrumentation**

**1** = None  
**2** = Pressure gauge  
**3** = Pressure transmitter  
**4** = Thermometer  
**5** = Pressure gauge and thermometer  
**6** = Pressure transmitter and thermometer

**7 Pump Suction Connector Type**

**C** = 1/2 in. female NPT  
**D** = 3/4 in. female NPT  
**M** = 1/2 in. Class 150 ANSI flange  
**N** = 1/2 in. Class 300 ANSI flange  
**P** = 3/4 in. Class 150 ANSI flange  
**Q** = 3/4 in. Class 300 ANSI flange

**8 Pump Suction Instrumentation**

**1** = None  
**2** = Pressure gauge  
**3** = Pressure transmitter

## API Plan 32 External Flush

API Plan 32 delivers a clean flush fluid into the seal chamber from an external source. Typically used with a close-clearance throat bushing, this arrangement can be used to ensure a higher pressure in the seal chamber. Flush fluid will migrate past the bushing, so it is important to ensure the flush fluid is chemically compatible with the process fluid and process fluid dilution not a concern.

### Plan 32

- Provides clean flush fluid to the seal chamber when the process fluid is unsuitable to be used as the flush fluid
- Increases the seal chamber pressure
- Isolates the process fluid from the seal chamber when used with a close-clearance throat bushing

Plan 32 is available as an assembled panel. The associated field installation kit for use in connecting the panel to your system is also available.

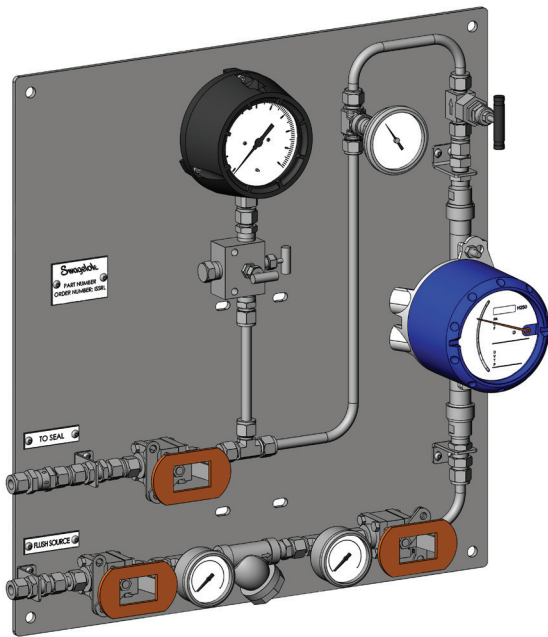

**Fig. 18 API Plan 32 Panel**

Panel shown with some optional components.

Panel contents may include:

- Swagelok tube fittings
- 63 series ball valves
- CH series check valve
- V series 2-valve manifold
- M4 model flowmeter
- N series needle valve
- Bimetal thermometer
- TTW series thermowell tee
- PGI series gauges
- Swagelok pipe fittings
- Pressure transmitter
- Mounting panel
- Brackets/miscellaneous hardware

See page 83 for additional information on individual components.

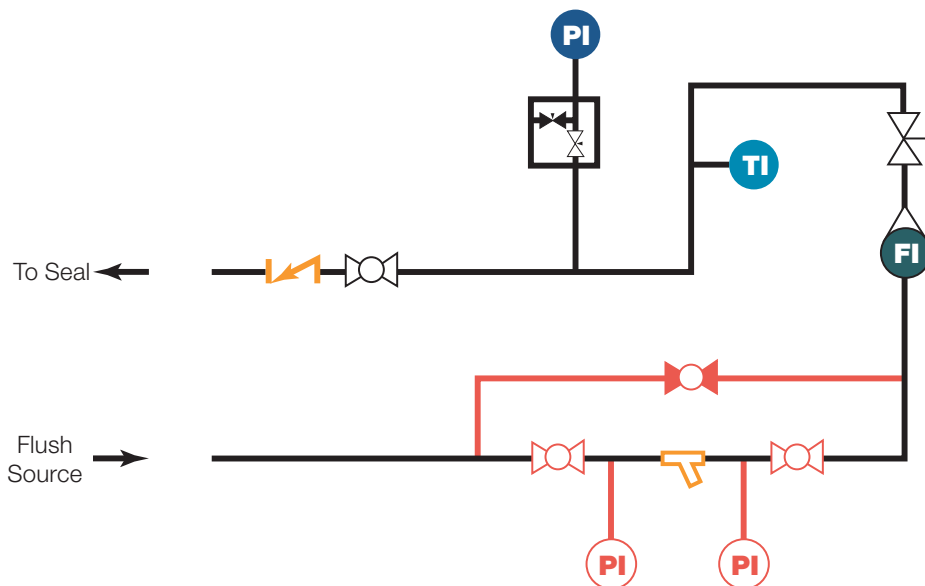

**Fig. 19 API Plan 32 P&ID**

Optional components shown in red.

Contact your authorized Swagelok sales and service center for information on optional components.

## API Plan 32 continued

## Ordering Information

Build an ordering number by combining the designators in the sequence shown below.

## Plan 32 Panel

SPA32 - <sup>1</sup>C - <sup>2</sup>C <sup>3</sup>5 - <sup>4</sup>M1

**1 Primary Tubing Size**

C = 1/2 in.  
K = 12 mm

**2 Filtration Options**

A = No options (filter only)  
B = Shut-off valves  
C = Manual bypass valves  
D = Inlet/outlet gauges  
F = Shut-off valve with inlet/outlet gauges  
G = Manual bypass valves with inlet/outlet gauges

**3 Instrumentation Options**

5 = Gauge and thermometer  
6 = Transmitter and thermometer

**4 Other Options**

M1 = Alloy 400 outlet  
M2 = All Alloy 400

## Plan 32 Field Installation Kit

The field installation kit contains tube fittings and a pipe nipple (optional).

SPK32 - <sup>1</sup>C - <sup>2</sup>C <sup>3</sup>4

**1 Primary Tubing Size**

C = 1/2 in.  
K = 12 mm

**2 Seal Connection**

B = 3/8 in. female NPT  
C = 1/2 in. female NPT  
D = 3/4 in. female NPT  
H = G 3/8  
J = G 1/2  
K = G 3/4

**3 Seal Connector Type**

1 = Standard female connector<sup>①</sup>  
2 = Standard male connector  
3 = 4 in. extended male connector, hex  
4 = 6 in. extended male connector, hex  
5 = 4 in. extended male connector, machined  
6 = 6 in. extended male connector, machined

<sup>①</sup> Installation will require use of pipe nipple (included in kit when female connector selected).

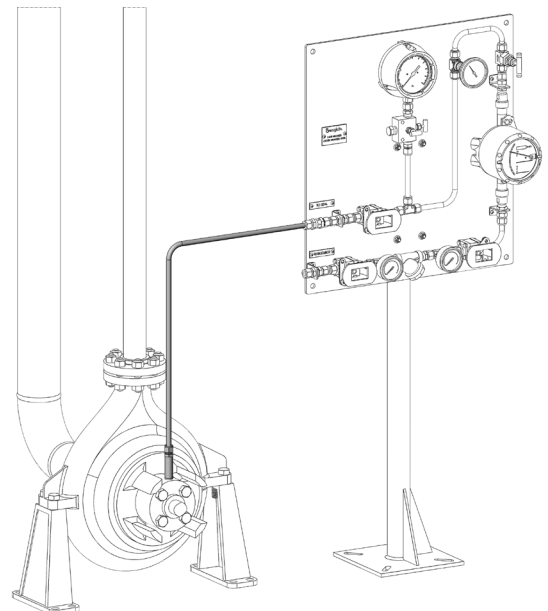

**Fig. 20 API Plan 32 Kit**  
Kit contents shown solid and include optional components.



## API Plan 41 Cooled Flush with Cyclone Separator

API Plan 41 is a cooled version of Plan 31. Solids are removed from the flush fluid by incorporating a cyclone separator. Flow is routed from the discharge side of the pump through the cyclone separator. Clean flush fluid leaving the separator is routed through a cooler before being returned to the seal chamber. Flush fluid containing solids is routed back into the suction side of the pump. In order for Plan 41 to be effective, it is recommended that the specific gravity of the solids be twice the specific gravity of the flush fluid.

### Plan 41

- Removes solids from the flush fluid
- Provides clean and cooled flush fluid to the seal chamber
- Removes heat from the seal chamber
- Ensures proper pressure in the seal chamber in order to prevent pumped fluid from vaporizing
- Allows seal chamber to be self-venting when used with horizontal pumps

Plan 41 is available as a kit of components ready for field assembly.

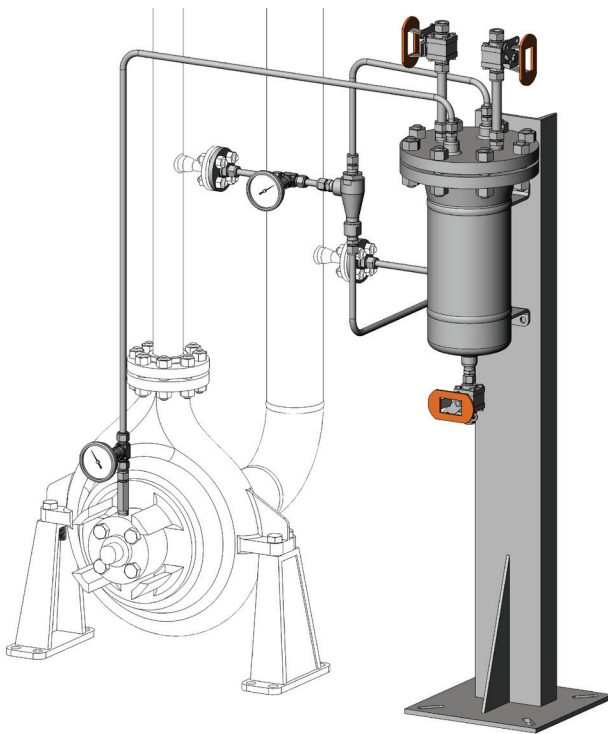

*Kit contents may include:*

- Swagelok tube fittings
- Flange adapters
- Pipe fittings
- V series 2-valve manifold
- 63 series ball valves
- Bimetal thermometer
- TTW series thermowell tee
- PGI series gauges
- Tubing
- Pressure transmitter
- Heat exchanger
- Heat exchanger stand
- Cyclone separator
- Pipe nipple

See page 83 for additional information on individual components.

**Fig. 21 API Plan 41**

Kit components shown solid and include some optional components.

## API Plan 41 continued

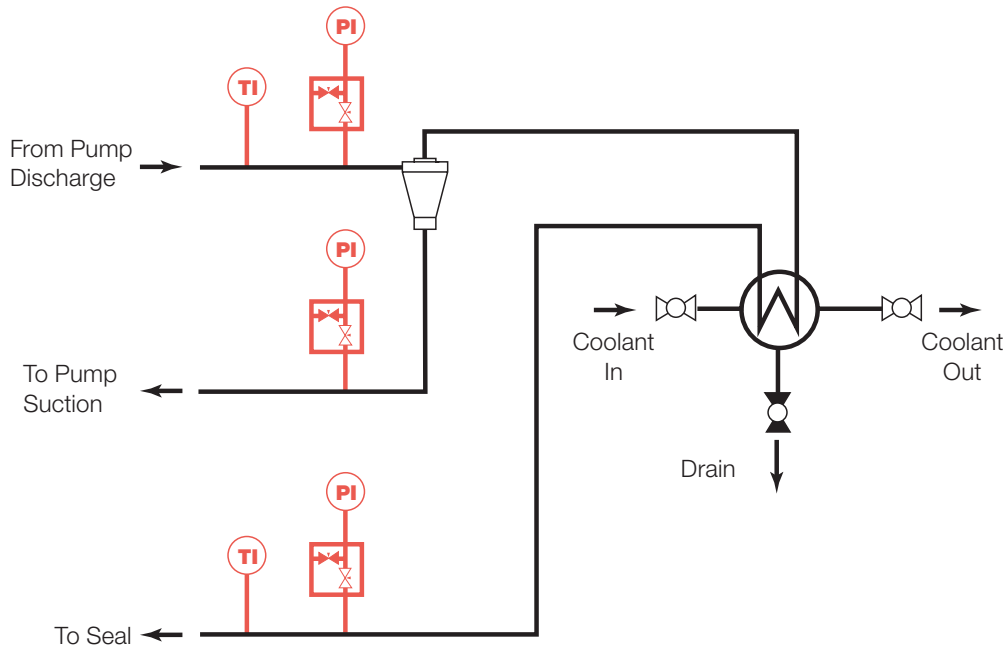

Fig. 22 Plan 41 P&amp;ID

Optional components shown in red.

Contact your authorized Swagelok sales and service center for information on optional components.

## Ordering Information

Build an ordering number by combining the designators in the sequence shown below.

## Plan 41 Kit

1   2   3   4   5   6   7   8  
 SPK41 - C - C 4 1 - C 1 - C 2

**1 Primary Tubing Size**

C = 1/2 in.  
K = 12 mm

**2 Seal Connection (Flush)**

B = 3/8 in. female NPT  
C = 1/2 in. female NPT  
D = 3/4 in. female NPT  
H = G 3/8  
J = G 1/2  
K = G 3/4

**3 Seal Connector Type (Flush)**

1 = Standard female connector<sup>①</sup>  
2 = Standard male connector  
3 = 4 in. extended male connector, hex  
4 = 6 in. extended male connector, hex  
5 = 4 in. extended male connector, machined  
6 = 6 in. extended male connector, machined

<sup>①</sup> Installation will require use of pipe nipple (included in kit when female connector selected).

**4 Seal Connection Instrumentation (Flush)**

1 = None  
2 = Pressure gauge  
3 = Pressure transmitter  
4 = Thermometer  
5 = Pressure gauge and thermometer  
6 = Pressure transmitter and thermometer

**5 Pump Discharge Connector Type**

C = 1/2 in. female NPT  
D = 3/4 in. female NPT  
M = 1/2 in. Class 150 ANSI flange  
N = 1/2 in. Class 300 ANSI flange  
P = 3/4 in. Class 150 ANSI flange  
Q = 3/4 in. Class 300 ANSI flange

**6 Pump Discharge Instrumentation**

1 = None  
2 = Pressure gauge  
3 = Pressure transmitter  
4 = Thermometer  
5 = Pressure gauge and thermometer  
6 = Pressure transmitter and thermometer

**7 Pump Suction Connector Type**

C = 1/2 in. female NPT  
D = 3/4 in. female NPT  
M = 1/2 in. Class 150 ANSI flange  
N = 1/2 in. Class 300 ANSI flange  
P = 3/4 in. Class 150 ANSI flange  
Q = 3/4 in. Class 300 ANSI flange

**8 Pump Suction Instrumentation**

1 = None  
2 = Pressure gauge  
3 = Pressure transmitter

## Between Seal Plans

### API Plan 52 Buffer Fluid Seal Pot

API Plan 52 utilizes a reservoir and circulates an unpressurized buffer fluid between the inboard and outboard seals. To provide positive circulation through the support system and into the seal, a pumping ring is employed. Frictional losses in the buffer fluid inlet and outlet lines should be minimized by selecting the proper tube size, using large radius and/or 45 degree bends, and reducing the length of tubing runs. Plan 52 is commonly used with light hydrocarbons or fluids with a high vapor pressure. The buffer fluid must be compatible with process fluid as inboard seal leakage will eventually mix with the buffer fluid.

#### Plan 52

- Provides additional heat removal from the inboard seal when required
- Acts as a secondary seal to prevent process fluid leakage to atmosphere

Plan 52 is available as a seal pot assembly. The associated field installation kit for use in connecting the seal pot assembly to your system is also available.

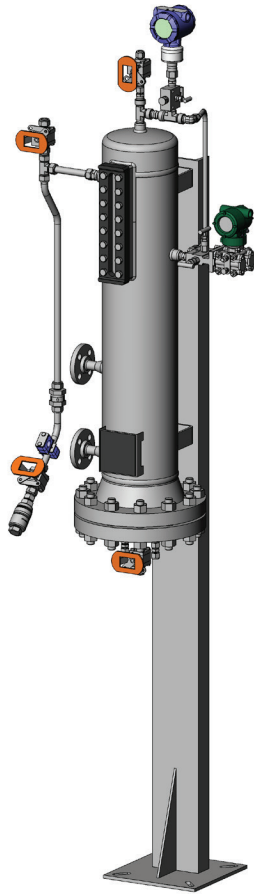

**Fig. 23 API Plan 52 Seal Pot Assembly**  
Assembly shown with some optional components.

*Assembly components may include:*

- Swagelok tube fittings
- 63 series ball valves
- CH series check valve
- V series 2-valve manifold
- QTM series quick-connects
- Bimetal thermometer
- TTW series thermowell tee
- PGI series gauges
- Swagelok pipe fittings
- Pressure transmitter
- Level transmitter
- Level switch
- Seal pot

See page 83 for additional information on individual components.

## API Plan 52 continued

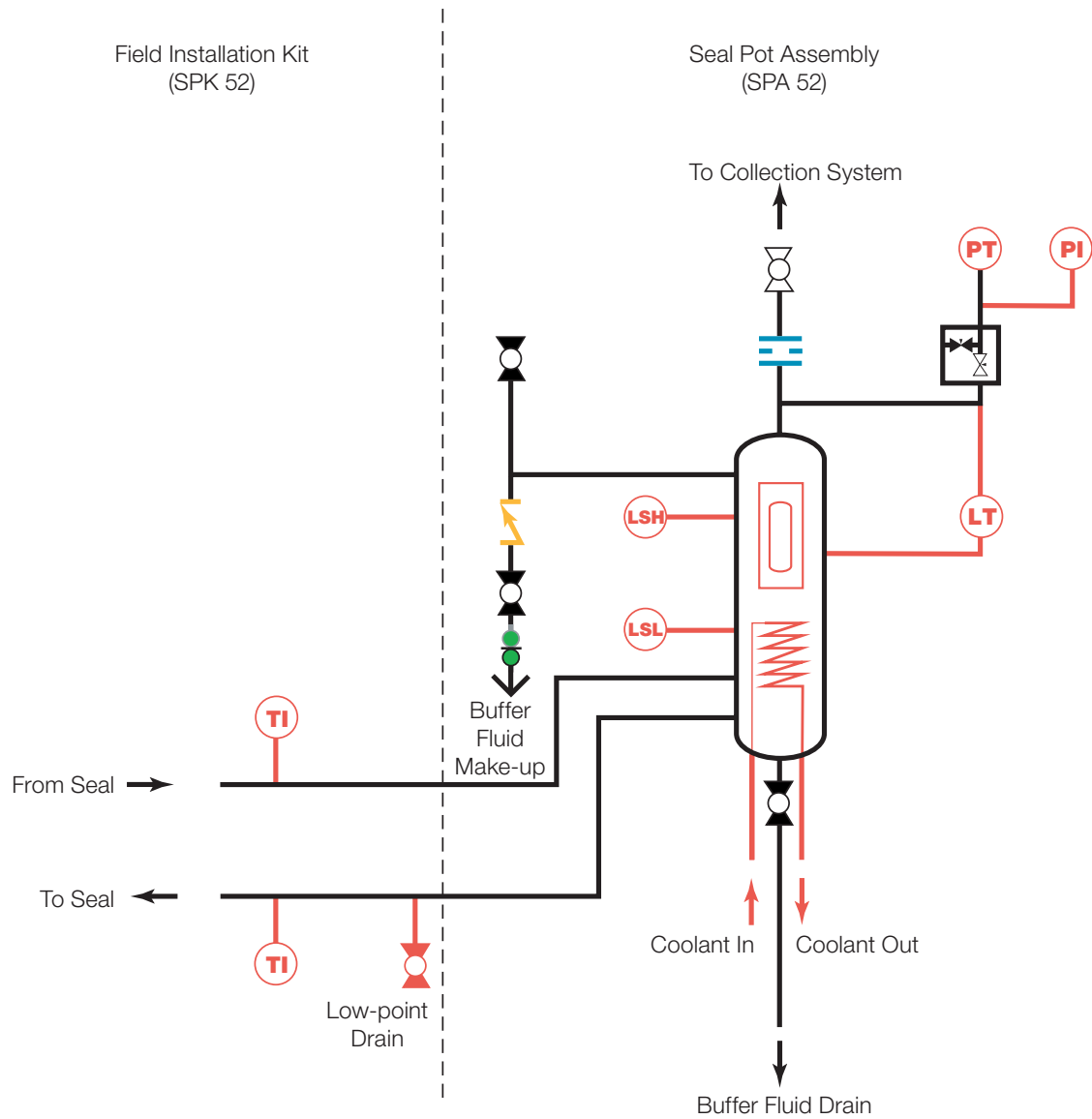

**Fig. 24 Plan 52 P&ID**  
Optional components shown in red.

Contact your authorized Swagelok sales and service center for information on optional components.

**API Plan 52 continued****Ordering Information**

Build an ordering number by combining the designators in the sequence shown below.

**Plan 52 Seal Pot Assembly**

SPA52 - **1** **2** **3** **4** **5** **6** **7** **8**  
**D** - **20** **U** **S** **D** **1** **D** **7**

**1 Primary Tubing Size**

**D** = 3/4 in.  
**L** = 18 mm

**2 Seal Pot Capacity**

**12** = 12 liters (3 gallons)  
**20** = 20 liters (5 gallons)  
**30** = 30 liters (8 gallons)  
**38** = 38 liters (10 gallons)

**3 Seal Pot Code**

**N** = None  
**P** = Pressure Equipment Directive (PED)  
**U** = ASME

**4 Seal Pot Material**

**S** = Carbon steel (painted)  
**4** = 304 stainless steel  
**6** = 316 stainless steel

**5 Seal Pot Basic Construction**

**A** = Dished bottom, without cooling coil  
**B** = Dished bottom, with cooling coil  
**C** = Flanged bottom, without cooling coil  
**D** = Flanged bottom, with cooling coil

**6 Seal Pot Inlet/Outlet Connections**

**1** = Flanged, inlet/outlet on left  
**2** = Flanged, inlet/outlet on right  
**3** = Swagelok tube fittings, inlet/outlet on left  
**4** = Swagelok tube fittings, inlet/outlet on right

**7 Seal Pot Level Measurement**

**A** = None  
**B** = Sight gauge only  
**C** = Sight gauge with level switches  
**D** = Sight gauge with level transmitter  
**E** = Level switches only  
**F** = Level transmitter only

**8 Seal Pot Pressure Measurement**

**2** = Pressure gauge  
**3** = Pressure transmitter  
**7** = Pressure transmitter and pressure gauge

## API Plan 52 continued

## Ordering Information

Build an ordering number by combining the designators in the sequence shown below.

## Plan 52 Field Installation Kit

The field installation kit contains tube fittings and tubing and may contain optional bimetal thermometer, TTW series thermowell tee, and pipe nipple.

SPK52 - **1** - **2** - **3** - **4** - **5** - **6** - **7** - **8** - **9**  
**D** - **C** 4 4 **B** - **C** 4 4 - **D**

**1 Primary Tubing Size**

**D** = 3/4 in.  
**L** = 18 mm

**2 Seal Connection (Buffer Inlet)**

**B** = 3/8 in. female NPT  
**C** = 1/2 in. female NPT  
**D** = 3/4 in. female NPT  
**H** = G 3/8  
**J** = G 1/2  
**K** = G 3/4

**3 Seal Connector Type (Buffer Inlet)**

**1** = Standard female connector<sup>①</sup>  
**2** = Standard male connector  
**3** = 4 in. extended male connector, hex  
**4** = 6 in. extended male connector, hex  
**5** = 4 in. extended male connector, machined  
**6** = 6 in. extended male connector, machined

<sup>①</sup> Installation will require use of pipe nipple (included in kit when female connector selected).

**4 Seal Connection Instrumentation (Buffer Inlet)**

**1** = None  
**4** = Thermometer

**5 Seal Connection Drain (Buffer Inlet)**

**A** = None  
**C** = Low point drain

**6 Seal Connection (Buffer Outlet)**

**B** = 3/8 in. female NPT  
**C** = 1/2 in. female NPT  
**D** = 3/4 in. female NPT  
**H** = G 3/8  
**J** = G 1/2  
**K** = G 3/4

**7 Seal Connector Type (Buffer Outlet)**

**1** = Standard female connector<sup>①</sup>  
**2** = Standard male connector  
**3** = 4 in. extended male connector, hex  
**4** = 6 in. extended male connector, hex  
**5** = 4 in. extended male connector, machined  
**6** = 6 in. extended male connector, machined

<sup>①</sup> Installation will require use of pipe nipple (included in kit when female connector selected).

**8 Seal Connection Instrumentation (Buffer Outlet)**

**1** = None  
**4** = Thermometer

**9 Seal Pot Connections**

**D** = 3/4 in. Swagelok tube fittings<sup>①</sup>  
**L** = 18 mm Swagelok tube fittings<sup>①</sup>  
**P** = 3/4 in. Class 150 ANSI flanges  
**Q** = 3/4 in. Class 300 ANSI flanges

<sup>①</sup> Must match the previously selected tubing size.

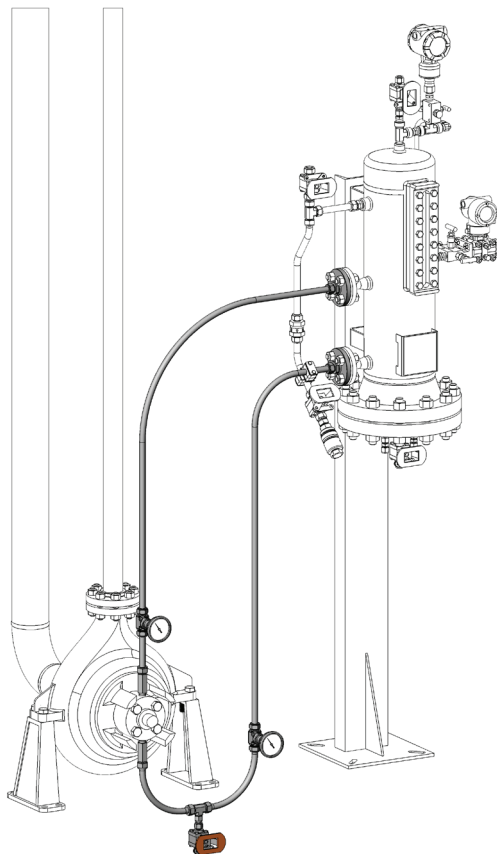

**Fig. 25 API Plan 52 Kit**  
 Kit contents shown solid and include some optional components.

## API Plan 53A Barrier Fluid Seal Pot Pressurized by Nitrogen

API Plan 53A utilizes a reservoir and circulates a pressurized barrier fluid between the inboard and outboard seals. The typical source of pressurization is plant nitrogen. The reservoir should be set at least 20 psi (1.3 bar) above maximum seal chamber pressure. This is to ensure that leakage across the inboard seal face is barrier fluid which then lubricates the seal faces and passes into the process. For this reason, barrier fluid must be chemically compatible with the process fluid and process dilution not a concern. In order to provide positive circulation through the support system and into the seal, a pumping ring is employed. A reservoir level indicator or level transmitter shows both inboard and outboard seal leakage.

Plan 53A

- Provides additional heat removal from inboard seal when required
- Is used with a dual seal arrangement when process leakage to atmosphere cannot occur

Plan 53A is available as a seal pot assembly. The associated field installation kit for use in connecting the assembly to your system is also available.

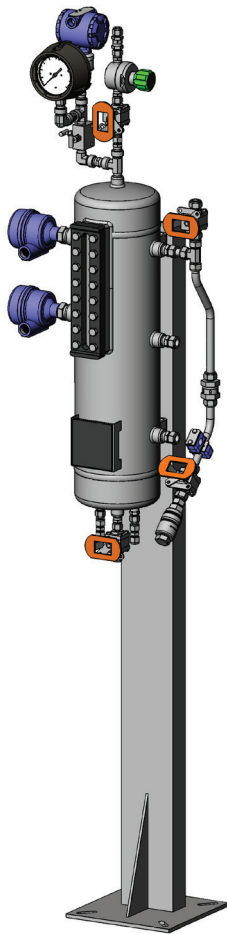

**Fig. 26 API Plan 53A Seal Pot Assembly**  
Assembly shown with some optional components.

*Assembly contents may include:*

- Swagelok tube fittings
- 63 series ball valves
- CH series check valve
- V series 2-valve manifold
- QTM series quick-connects
- Bimetal thermometer
- TTW series thermowell tee
- PGI series gauges
- KHF series pressure regulator
- Swagelok pipe fittings
- Pressure transmitter
- Level transmitter
- Level switch
- Seal pot

See page 83 for additional information on individual components.

API Plan 53A continued

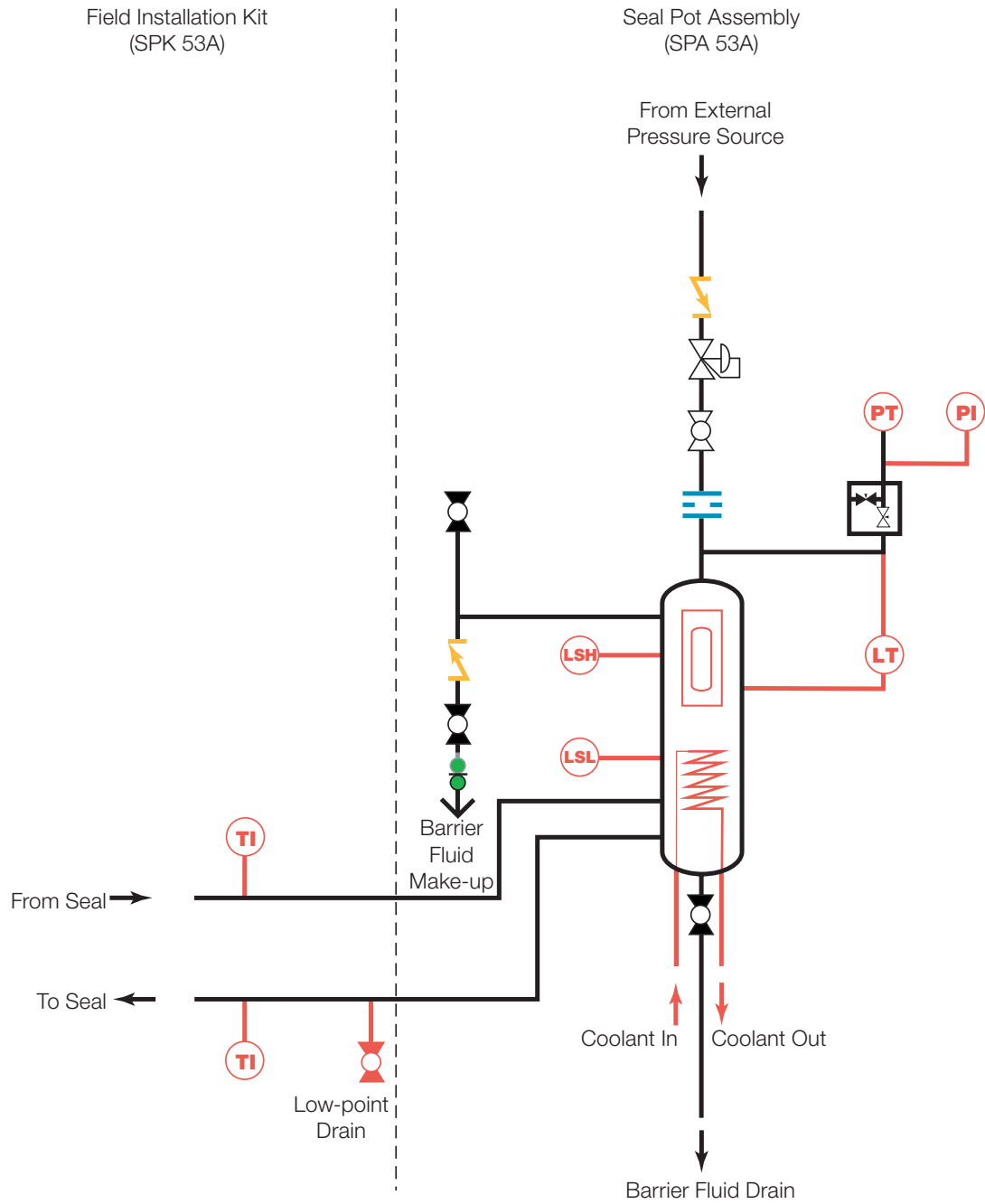

**Fig. 27 Plan 53A P&ID**  
Optional components shown in red.

Contact your authorized Swagelok sales and service center for information on optional components.



**API Plan 53A continued****Ordering Information**

Build an ordering number by combining the designators in the sequence shown below.

**Plan 53A Seal Pot Assembly**

SPA53A - **1** - **2** **3** **4** **5** **6** **7** **8**  
**D** - **20** **U** **S** **D** **1** **D** **7**

**1 Primary Tubing Size**

**D** = 3/4 in.  
**L** = 18 mm

**2 Seal Pot Capacity**

**12** = 12 liters (3 gallons)  
**20** = 20 liters (5 gallons)  
**30** = 30 liters (8 gallons)  
**38** = 38 liters (10 gallons)

**3 Seal Pot Code**

**N** = None  
**P** = Pressure Equipment Directive (PED)  
**U** = ASME

**4 Seal Pot Material**

**S** = Carbon steel (painted)  
**4** = 304 stainless steel  
**6** = 316 stainless steel

**5 Seal Pot Basic Construction**

**A** = Dished bottom, without cooling coil  
**B** = Dished bottom, with cooling coil  
**C** = Flanged bottom, without cooling coil  
**D** = Flanged bottom, with cooling coil

**6 Seal Pot Inlet/Outlet Connections**

**1** = Flanged, inlet/outlet on left  
**2** = Flanged, inlet/outlet on right  
**3** = Swagelok tube fittings, inlet/outlet on left  
**4** = Swagelok tube fittings, inlet/outlet on right

**7 Seal Pot Level Measurement**

**A** = None  
**B** = Sight gauge only  
**C** = Sight gauge with level switches  
**D** = Sight gauge with level transmitter  
**E** = Level switches only  
**F** = Level transmitter only

**8 Seal Pot Pressure Measurement**

**2** = Pressure gauge  
**3** = Pressure transmitter  
**7** = Pressure transmitter and pressure gauge

## API Plan 53A continued

## Ordering Information

Build an ordering number by combining the designators in the sequence shown below.

## Plan 53A Field Installation Kit

The field installation kit contains tube fittings and tubing and may contain optional bimetal thermometer, TTW series thermowell tee, and pipe nipple.

SPK53A - **1** **2** **3** **4** **5** **6** **7** **8** **9**  
 - **D** - **C** **4** **4** **B** - **C** **4** **4** - **D**

**1 Primary Tubing Size**

**D** = 3/4 in.  
**L** = 18 mm

**2 Seal Connection (Barrier Inlet)**

**B** = 3/8 in. female NPT  
**C** = 1/2 in. female NPT  
**D** = 3/4 in. female NPT  
**H** = G 3/8  
**J** = G 1/2  
**K** = G 3/4

**3 Seal Connector Type (Barrier Inlet)**

**1** = Standard female connector<sup>①</sup>  
**2** = Standard male connector  
**3** = 4 in. extended male connector, hex  
**4** = 6 in. extended male connector, hex  
**5** = 4 in. extended male connector, machined  
**6** = 6 in. extended male connector, machined

<sup>①</sup> Installation will require use of pipe nipple (included in kit when female connector selected).

**4 Seal Connection Instrumentation (Barrier Inlet)**

**1** = None  
**4** = Thermometer

**5 Seal Connection Drain (Barrier Inlet)**

**A** = None  
**C** = Low point drain

**6 Seal Connection (Barrier Outlet)**

**B** = 3/8 in. female NPT  
**C** = 1/2 in. female NPT  
**D** = 3/4 in. female NPT  
**H** = G 3/8  
**J** = G 1/2  
**K** = G 3/4

**7 Seal Connector Type (Barrier Outlet)**

**1** = Standard female connector<sup>①</sup>  
**2** = Standard male connector  
**3** = 4 in. extended male connector, hex  
**4** = 6 in. extended male connector, hex  
**5** = 4 in. extended male connector, machined  
**6** = 6 in. extended male connector, machined

<sup>①</sup> Installation will require use of pipe nipple (included in kit when female connector selected).

**8 Seal Connection Instrumentation (Barrier Outlet)**

**1** = None  
**4** = Thermometer

**9 Seal Pot Connections**

**D** = 3/4 in. Swagelok tube fittings<sup>①</sup>  
**L** = 18 mm Swagelok tube fittings<sup>①</sup>  
**P** = 3/4 in. Class 150 ANSI flanges  
**Q** = 3/4 in. Class 300 ANSI flanges

<sup>①</sup> Must match the previously selected tubing size.

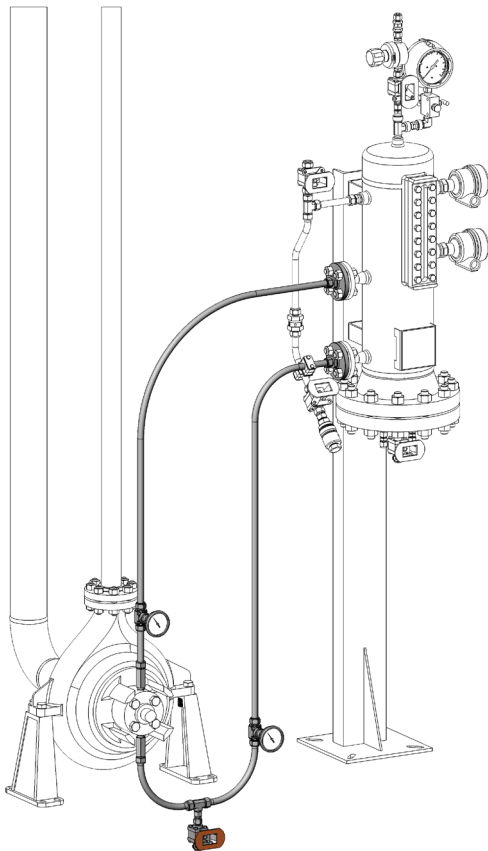

**Fig. 28 API Plan 53A Kit**  
 Kit contents shown solid and include optional components.

## API Plan 53B Barrier Fluid Pressurized by Bladder Accumulator

API Plan 53B circulates a pressurized barrier fluid between the inboard and outboard seals. The source of pressurization is a bladder accumulator. Plan 53B has the advantage of not allowing gas absorption into the barrier fluid which may allow for operation at higher pressures than Plan 53A. Barrier fluid pressure should be monitored as an indicator of seal leakage. Barrier fluid will leak across the inboard seal face and pass into the process. For this reason, the barrier fluid must be chemically compatible with the process fluid and process dilution not a concern. In order to provide positive circulation through the support system and into the seal, a pumping ring is employed. Heat removal is achieved by using a heat exchanger.

Plan 53B

- Attains a higher barrier fluid pressure with the use of a pressurized bladder accumulator
- Provides additional heat removal from inner seal when required

Plan 53B is available as an assembly. The associated field installation kit for use in connecting the assembly to your system is also available.

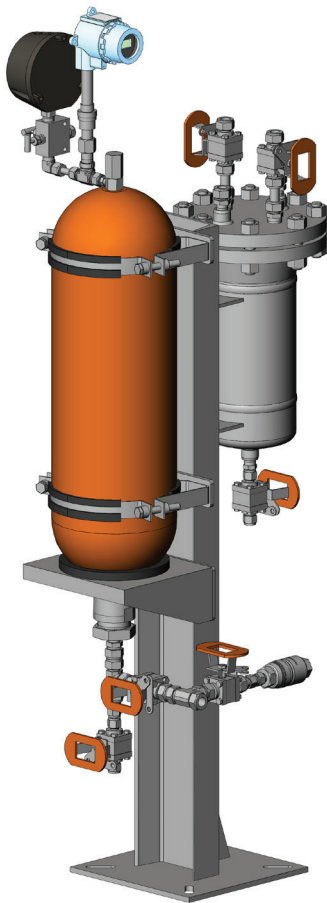

**Fig. 29 API Plan 53B Assembly**

Assembly shown with some optional components.

*Assembly contents may include:*

- Swagelok tube fittings
- 63 series ball valves
- V series 2-valve manifold
- QTM series quick-connects
- PGI series gauges
- TTW series thermowell tee
- Swagelok pipe fittings
- Pressure transmitter
- Temperature transmitter
- Bladder accumulator
- Permanent gauge head
- Heat exchanger

See page 83 for additional information on individual components.

## API Plan 53B continued

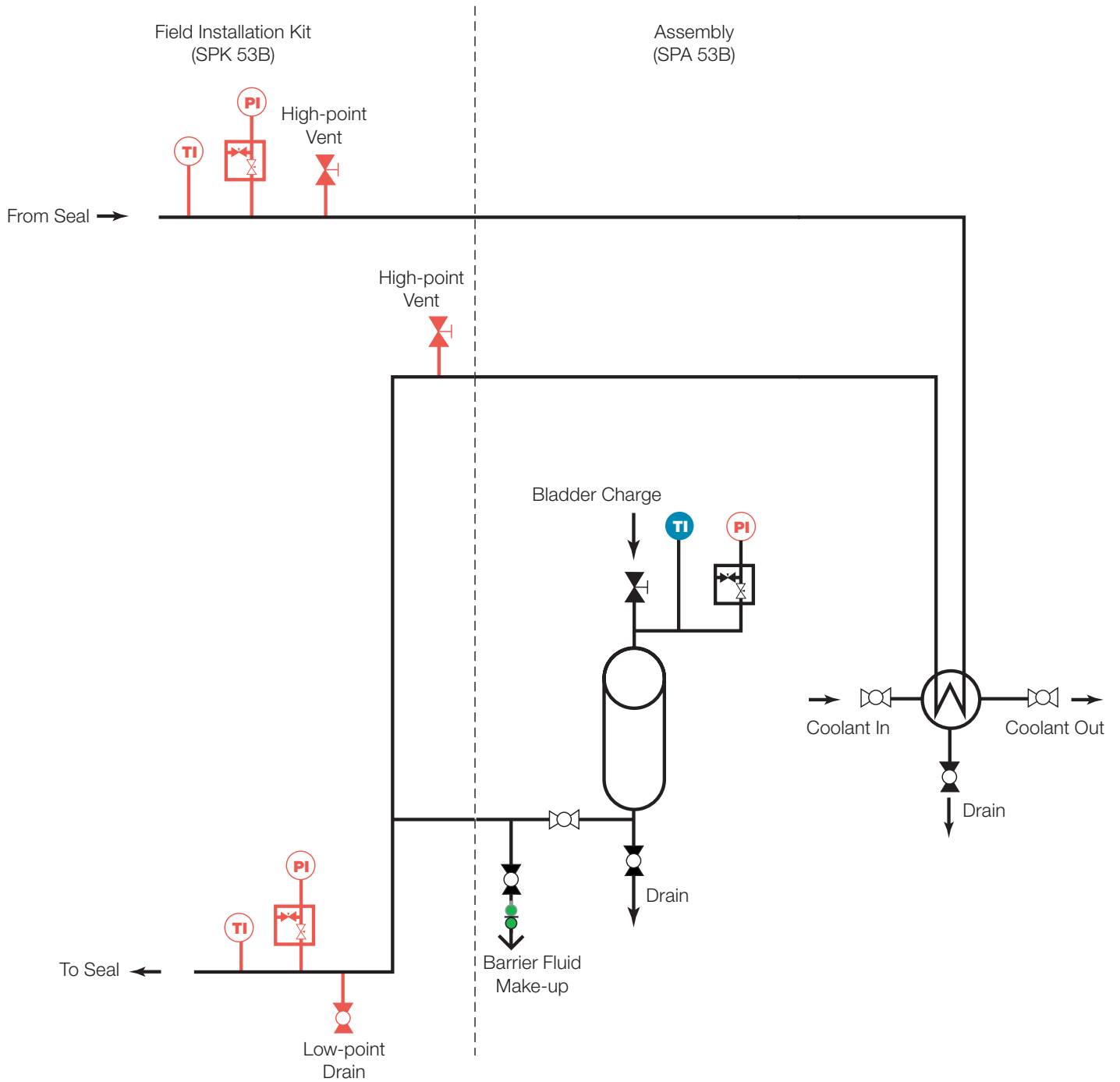

**Fig. 30 Plan 53B P&ID**  
Optional components shown in red.

Contact your authorized Swagelok sales and service center for information on optional components.

**API Plan 53B continued****Ordering Information**

Build an ordering number by combining the designators in the sequence shown below.

**Plan 53B Assembly**

SPA53B - **1** **D** - **2** **20** **3** **N** **4** **S** **5** **3** **6** **8**

**1 Primary Tubing Size**

**D** = 3/4 in.  
**L** = 18 mm

**2 Bladder Accumulator Capacity**

**20** = 20 liters (5 gallons)  
**35** = 35 liters (9 gallons)

**3 Bladder Accumulator Code**

**N** = None  
**P** = Pressure Equipment Directive (PED)  
**U** = ASME

**4 Bladder Accumulator Material**

**S** = Carbon steel (painted)  
**4** = 304 stainless steel  
**6** = 316 stainless steel

**5 Bladder Accumulator Connections**

**3** = Swagelok tube fittings, connection on left  
**4** = Swagelok tube fittings, connection on right

**6 Bladder Accumulator Pressure/Temperature Measurement**

**8** = Temperature transmitter and pressure gauge  
**9** = Temperature and pressure transmitter

## API Plan 53B continued

## Ordering Information

Build an ordering number by combining the designators in the sequence shown below.

## Plan 53B Field Installation Kit

The field installation kit contains tube fittings and tubing and may contain optional bimetal thermometer, TTW series thermowell tee, V series 2-valve manifold, PGI series gauges, 63 series ball valves, 1 series needle valve, pressure transmitters, and pipe nipples.

SPK53B - **1** - **D** - **2** - **C** **3** **4** **4** **5** - **6** **7** **8** **9** **B**

**1 Primary Tubing Size**

**D** = 3/4 in.  
**L** = 18 mm

**2 Seal Connection (Barrier Inlet)**

**B** = 3/8 in. female NPT  
**C** = 1/2 in. female NPT  
**D** = 3/4 in. female NPT  
**H** = G 3/8  
**J** = G 1/2  
**K** = G 3/4

**3 Seal Connector Type (Barrier Inlet)**

**1** = Standard female connector<sup>①</sup>  
**2** = Standard male connector  
**3** = 4 in. extended male connector, hex  
**4** = 6 in. extended male connector, hex  
**5** = 4 in. extended male connector, machined  
**6** = 6 in. extended male connector, machined

<sup>①</sup> Installation will require use of pipe nipple (included in kit when female connector selected).

**4 Seal Connection Instrumentation (Barrier Inlet)**

**1** = None  
**2** = Pressure gauge  
**3** = Pressure transmitter  
**4** = Thermometer  
**5** = Pressure gauge and thermometer  
**6** = Pressure transmitter and thermometer

**5 Seal Connection Drain/Vent (Barrier Inlet)**

**A** = None  
**B** = High point vent  
**C** = Low point drain  
**D** = High point vent and low point drain

**6 Seal Connection (Barrier Outlet)**

**B** = 3/8 in. female NPT  
**C** = 1/2 in. female NPT  
**D** = 3/4 in. female NPT  
**H** = G 3/8  
**J** = G 1/2  
**K** = G 3/4

**7 Seal Connector Type (Barrier Outlet)**

**1** = Standard female connector<sup>①</sup>  
**2** = Standard male connector  
**3** = 4 in. extended male connector, hex  
**4** = 6 in. extended male connector, hex  
**5** = 4 in. extended male connector, machined  
**6** = 6 in. extended male connector, machined

<sup>①</sup> Installation will require use of pipe nipple (included in kit when female connector selected).

**8 Seal Connection Instrumentation (Barrier Outlet)**

**1** = None  
**2** = Pressure gauge  
**3** = Pressure transmitter  
**4** = Thermometer  
**5** = Pressure gauge and thermometer  
**6** = Pressure transmitter and thermometer

**9 Seal Connection Vent (Barrier Outlet)**

**A** = None  
**B** = High point vent

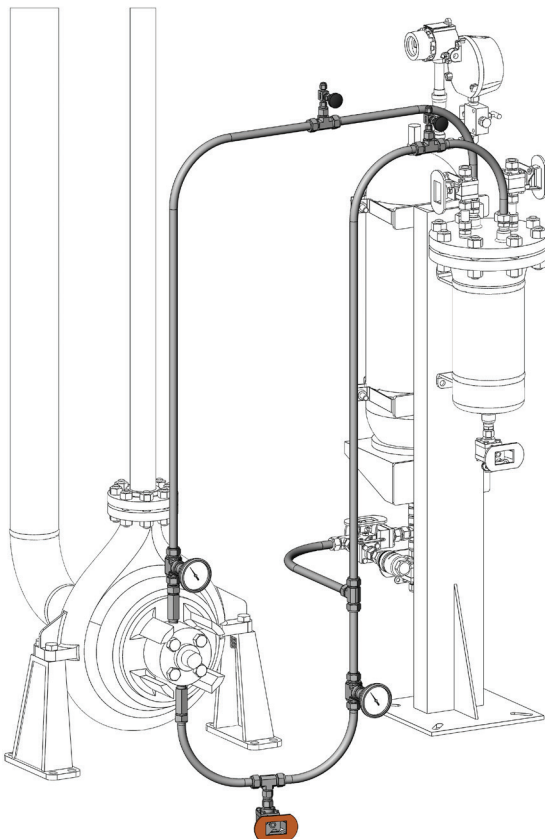

**Fig. 31 API Plan 53B Kit**  
Kit contents shown solid and include optional components.

## API Plan 53C Barrier Fluid Pressurized by Piston Accumulator

API Plan 53C circulates a pressurized barrier fluid between the inboard and outboard seals. The source of pressurization is a piston accumulator. Plan 53C is preferred for applications where the seal chamber pressure may vary during pump operation. A sensing line is typically run from the seal chamber into the piston accumulator, allowing for a constant pressure differential to be maintained. As with Plan 53A and Plan 53B, barrier fluid must be compatible with process fluid and some level of process dilution be acceptable. In order to provide positive circulation through the support system and into the seal, a pumping ring is employed. Heat removal is achieved by using a heat exchanger.

### Plan 53C

- Provides additional heat removal from inboard seal when required
- Is used when the seal chamber pressure can vary during pump operation
- Is used when process leakage to atmosphere cannot occur

Plan 53C is available as an assembly. The associated field installation kit for use in connecting the assembly to your system is also available.

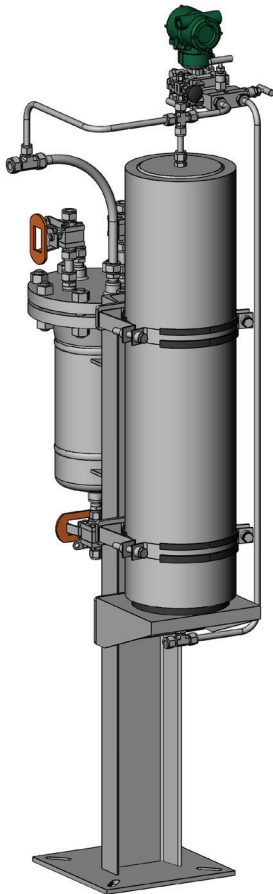

### Assembly contents may include:

- Swagelok tube fittings
- 63 series ball valves
- 1 series needle valve
- V series 2-valve manifold
- QTM series quick-connects
- TTW series thermowell tee
- Swagelok pipe fittings
- Differential pressure transmitter
- Level transmitter
- Level switches
- Level indicator
- Piston accumulator

See page 83 for additional information on individual components.

**Fig. 32 API Plan 53C Assembly**

Assembly shown with some optional components.

API Plan 53C continued

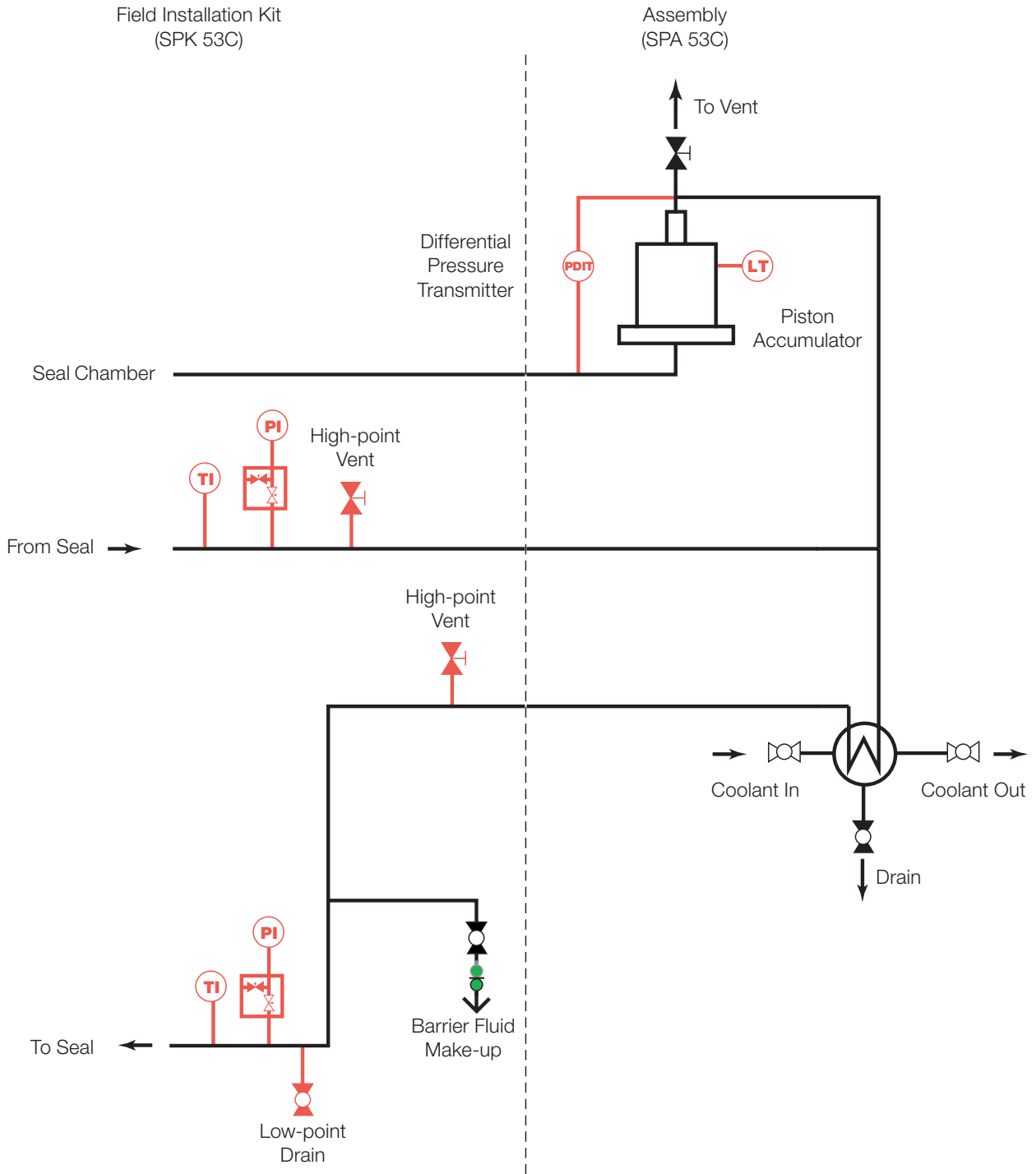

**Fig. 33 Plan 53C P&ID**  
Optional components shown in red.

Contact your authorized Swagelok sales and service center for information on optional components.



**API Plan 53C continued****Ordering Information**

Build an ordering number by combining the designators in the sequence shown below.

**Plan 53C Assembly**

SPA53C - **1** **D** - **2** **N** **3** **S** **4** **5** **D**

**1 Primary Tubing Size**

**D** = 3/4 in.  
**L** = 18 mm

**2 Bladder Accumulator Code**

**N** = None  
**P** = Pressure Equipment Directive (PED)  
**U** = ASME

**3 Piston Accumulator Material**

**S** = Carbon steel (painted)  
**4** = 304 stainless steel  
**6** = 316 stainless steel

**4 Piston Accumulator Connection**

**3** = Swagelok tube fittings, connection on left  
**4** = Swagelok tube fittings, connection on right

**5 Piston Accumulator Level Measurement**

**A** = None  
**B** = Level gauge only  
**C** = Level gauge with level switches  
**D** = Level gauge with level transmitter

## API Plan 53C continued

## Ordering Information

Build an ordering number by combining the designators in the sequence shown below.

## Plan 53C Field Installation Kit

The field installation kit contains tube fittings and tubing and may contain an optional bimetal thermometer, TTW series thermowell tee, V series 2-valve manifold, PGI series gauges, 63 series ball valves, 1 series needle valve, QTM series quick-connect, pressure transmitters, and pipe nipples.

SPK53C - **1** - **2** - **3** - **4** - **5** - **6** - **7** - **8** - **9** - **10** - **11**  
**D** - **C** **4** **4** **D** - **C** **4** **1** **B** - **C** **2**

**1 Primary Tubing Size**

- D** = 3/4 in.
- L** = 18 mm

**2 Seal Connection (Barrier Inlet)**

- B** = 3/8 in. female NPT
- C** = 1/2 in. female NPT
- D** = 3/4 in. female NPT
- H** = G 3/8
- J** = G 1/2
- K** = G 3/4

**3 Seal Connector Type (Barrier Inlet)**

- 1** = Standard female connector<sup>①</sup>
- 2** = Standard male connector
- 3** = 4 in. extended male connector, hex
- 4** = 6 in. extended male connector, hex
- 5** = 4 in. extended male connector, machined
- 6** = 6 in. extended male connector, machined

<sup>①</sup> Installation will require use of pipe nipple (included in kit when female connector selected).

**4 Seal Connection Instrumentation (Barrier Inlet)**

- 1** = None
- 2** = Pressure gauge
- 3** = Pressure transmitter
- 4** = Thermometer
- 5** = Pressure gauge and thermometer
- 6** = Pressure transmitter and thermometer

**5 Seal Connection Drain/Vent (Barrier Inlet)**

- A** = None
- B** = High point vent
- C** = Low point drain
- D** = High point vent and low point drain

**6 Seal Connection (Barrier Outlet)**

- B** = 3/8 in. female NPT
- C** = 1/2 in. female NPT
- D** = 3/4 in. female NPT
- H** = G 3/8
- J** = G 1/2
- K** = G 3/4

**7 Seal Connector Type (Barrier Outlet)**

- 1** = Standard female connector<sup>①</sup>
- 2** = Standard male connector
- 3** = 4 in. extended male connector, hex
- 4** = 6 in. extended male connector, hex
- 5** = 4 in. extended male connector, machined
- 6** = 6 in. extended male connector, machined

<sup>①</sup> Installation will require use of pipe nipple (included in kit when female connector selected).

**8 Seal Connection Instrumentation (Barrier Outlet)**

- 1** = None
- 2** = Pressure gauge
- 3** = Pressure transmitter
- 4** = Thermometer
- 5** = Pressure gauge and thermometer
- 6** = Pressure transmitter and thermometer

**9 Seal Connection Vent (Barrier Outlet)**

- A** = None
- B** = High point vent

**10 Seal Connection (Seal Chamber)**

- B** = 3/8 in. female NPT
- C** = 1/2 in. female NPT
- D** = 3/4 in. female NPT
- H** = G 3/8
- J** = G 1/2
- K** = G 3/4

**11 Seal Connector Type (Seal Chamber)**

- 1** = Standard female connector<sup>①</sup>
- 2** = Standard male connector
- 3** = 4 in. extended male connector, hex
- 4** = 6 in. extended male connector, hex
- 5** = 4 in. extended male connector, machined
- 6** = 6 in. extended male connector, machined

<sup>①</sup> Installation will require use of pipe nipple (included in kit when female connector selected).

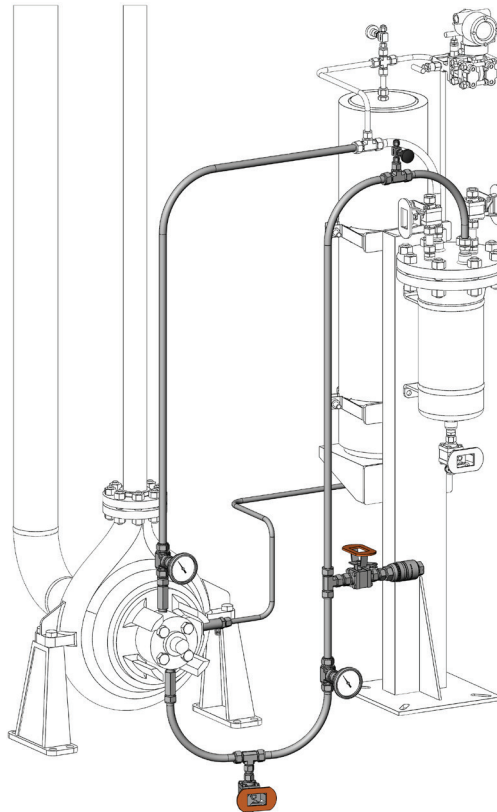

**Fig. 34 API Plan 53C Kit**  
 Kit contents shown solid and include optional components.

## API Plan 54 Barrier Fluid Pressurized by External System

API Plan 54 is a custom engineered system that delivers a pressurized barrier fluid to the seal chamber. The barrier liquid is circulated to and from the seal chamber via a pump located on an external reservoir. This fluid is maintained at a pressure greater than that found in the seal chamber. A Plan 54 can contain filters, coolers, and other components that are selected according to the specific parameters of the application.

Plan 54 provides a cool, clean, pressurized barrier fluid to a dual pressurized seal.

Plan 54 is available as a seal skid assembly. The associated field installation kit for use in connecting the assembly to your system is also available.

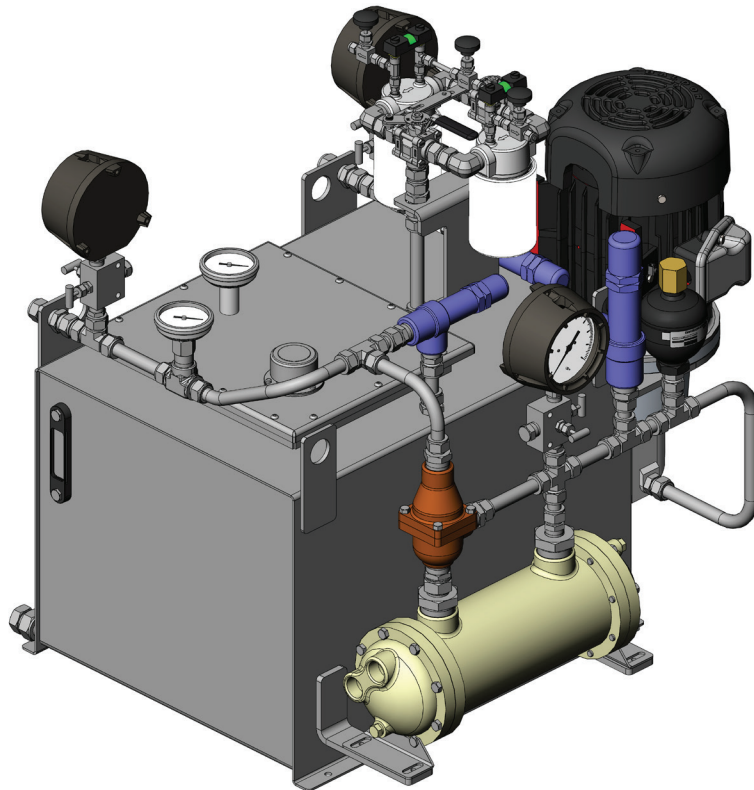

**Fig. 35 API Plan 54 Assembly**  
Assembly shown with some optional components.

*Assembly contents may include:*

- Swagelok tube fittings
- 63 series ball valves
- 1 series needle valve
- V series 2-valve manifold
- Bimetal thermometer
- TTW series thermowell tee
- Thermowell
- Hydraulic reservoir
- Swagelok pipe fittings
- Pump/coupling/motor
- Diaphragm accumulator
- Shell and tube head exchanger
- Thermostatic mixing valve
- Filter heads/elements
- Differential pressure indicators
- Suction strainer
- Flow/pressure control valves

See page 83 for additional information on individual components.

API Plan 54 continued

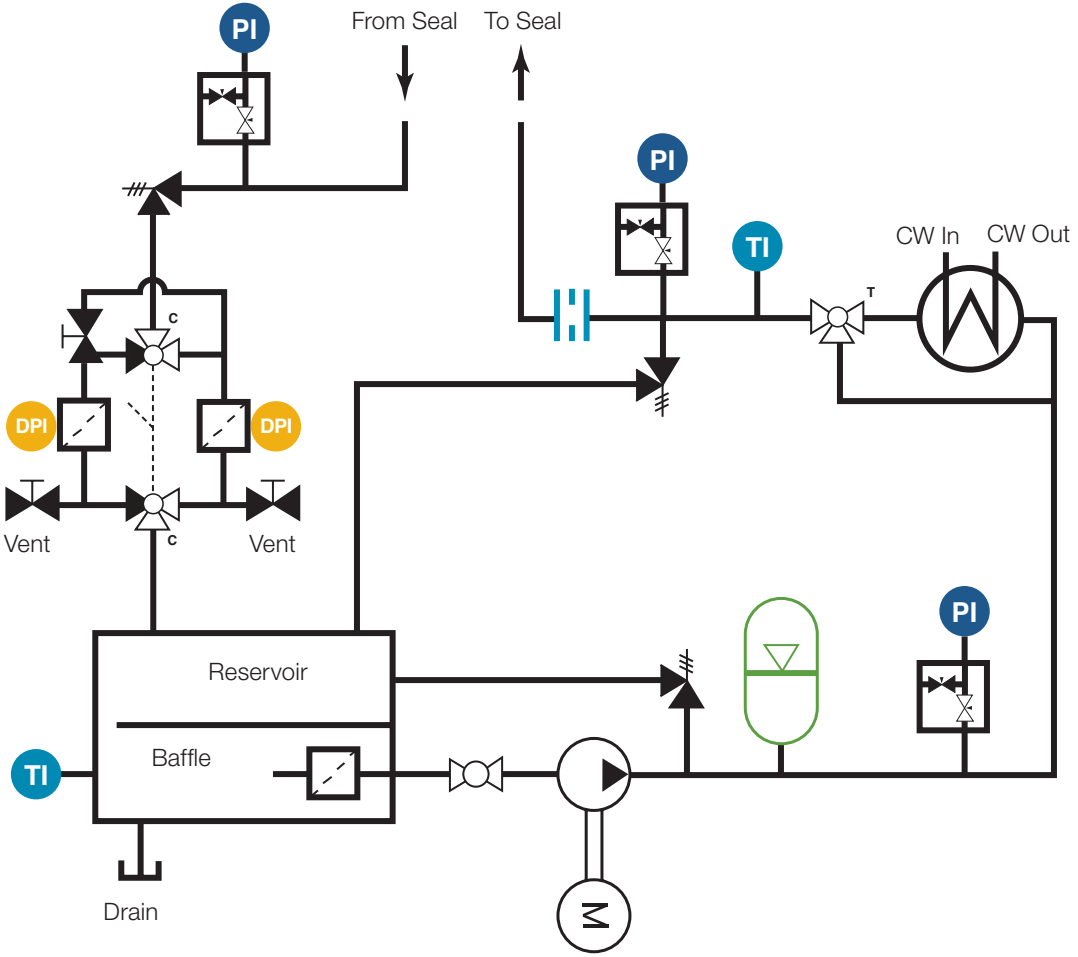

Fig. 36 Plan 54 P&ID

Contact your authorized Swagelok sales and service center for information on optional components.

**API Plan 54 continued****Ordering Information**

Build an ordering number by combining the designators in the sequence shown below.

**Plan 54 Assembly**

SPA54 - **1** - **D** - **2** - **05** **3** **A** **4** **2** **5** **K** - **6** **4** **7** **B** **8** **4**

**1 Primary Tubing Size**

**D** = 3/4 in.  
**L** = 18 mm

**2 Flow Capacity**

**05** = 5 gallons (18.9 liters) per minute  
**10** = 10 gallons (37.9 liters) per minute  
**15** = 15 gallons (56.8 liters) per minute

**3 Pump**

**A** = Single gear pump

**4 Cooling**

**1** = None  
**2** = Shell and tube exchanger

**5 Filtration**

**K** = Dual filters with switching valves and DP gauges

**6 Reservoir material**

**4** = 304 stainless steel  
**6** = 316 stainless steel

**7 Reservoir Level Measurement**

**B** = Sight gauge only

**8 Reservoir Temperature Measurement**

**1** = None  
**4** = Bimetal thermometer

## API Plan 54 continued

## Ordering Information

Build an ordering number by combining the designators in the sequence shown below.

## Plan 54 Field Installation Kit

The field installation kit contains tube fittings and tubing and may contain an optional bimetal thermometer, TTW series thermowell tee, V series 2-valve manifold, PGI series gauges, 63 series ball valves, pressure transmitters, and pipe nipples.

1    2    3    4    5    6    7    8  
 SPK54 - D - C 4 1 B - C 4 1

**1 Primary Tubing Size**

D = 3/4 in.  
L = 18 mm

**2 Seal Connection (Barrier Inlet)**

B = 3/8 in. female NPT  
C = 1/2 in. female NPT  
D = 3/4 in. female NPT  
H = G 3/8  
J = G 1/2  
K = G 3/4

**3 Seal Connector Type (Barrier Inlet)**

1 = Standard female connector<sup>①</sup>  
2 = Standard male connector  
3 = 4 in. extended male connector, hex  
4 = 6 in. extended male connector, hex  
5 = 4 in. extended male connector, machined  
6 = 6 in. extended male connector, machined

<sup>①</sup> Installation will require use of pipe nipple (included in kit when female connector selected).

**4 Seal Connection Instrumentation (Barrier Inlet)**

1 = None  
2 = Pressure gauge  
3 = Pressure transmitter  
4 = Thermometer  
5 = Pressure gauge and thermometer  
6 = Pressure transmitter and thermometer

**5 Seal Connection Drain (Barrier Inlet)**

A = None  
C = Low point drain

**6 Seal Connection (Barrier Outlet)**

B = 3/8 in. female NPT  
C = 1/2 in. female NPT  
D = 3/4 in. female NPT  
H = G 3/8  
J = G 1/2  
K = G 3/4

**7 Seal Connector Type (Barrier Outlet)**

1 = Standard female connector<sup>①</sup>  
2 = Standard male connector  
3 = 4 in. extended male connector, hex  
4 = 6 in. extended male connector, hex  
5 = 4 in. extended male connector, machined  
6 = 6 in. extended male connector, machined

<sup>①</sup> Installation will require use of pipe nipple (included in kit when female connector selected).

**8 Seal Connection Instrumentation (Barrier Outlet)**

1 = None  
2 = Pressure gauge  
3 = Pressure transmitter  
4 = Thermometer  
5 = Pressure gauge and thermometer  
6 = Pressure transmitter and thermometer

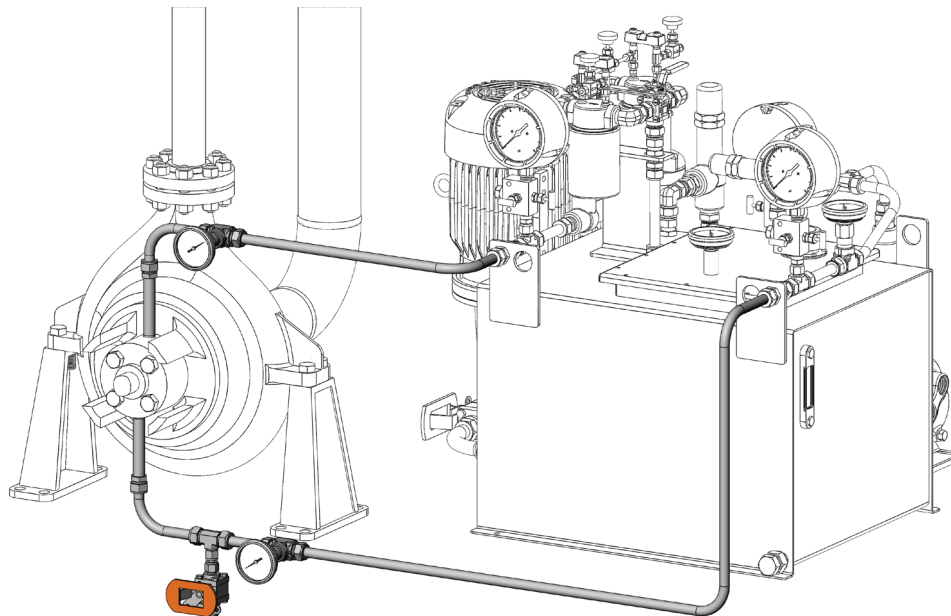

**Fig. 37 API Plan 54 Kit**  
Kit contents shown solid and include optional components.

## API Plan 55 Buffer Fluid Circulated by External System

API Plan 55 is a custom engineered system that delivers an unpressurized buffer fluid to the seal chamber. The buffer liquid is circulated to and from the seal chamber via a pump located on an external reservoir. A Plan 55 can contain filters, coolers, and other components that are selected according to the specific parameters of the application. This system provides both cooling and lubrication to the outboard seal independent of the operation of the pump.

Plan 55 provides a cool, clean, unpressurized buffer fluid to a dual pressurized seal.

Plan 55 is available as a seal skid assembly. The associated field installation kit for use in connecting the assembly to your system is also available.

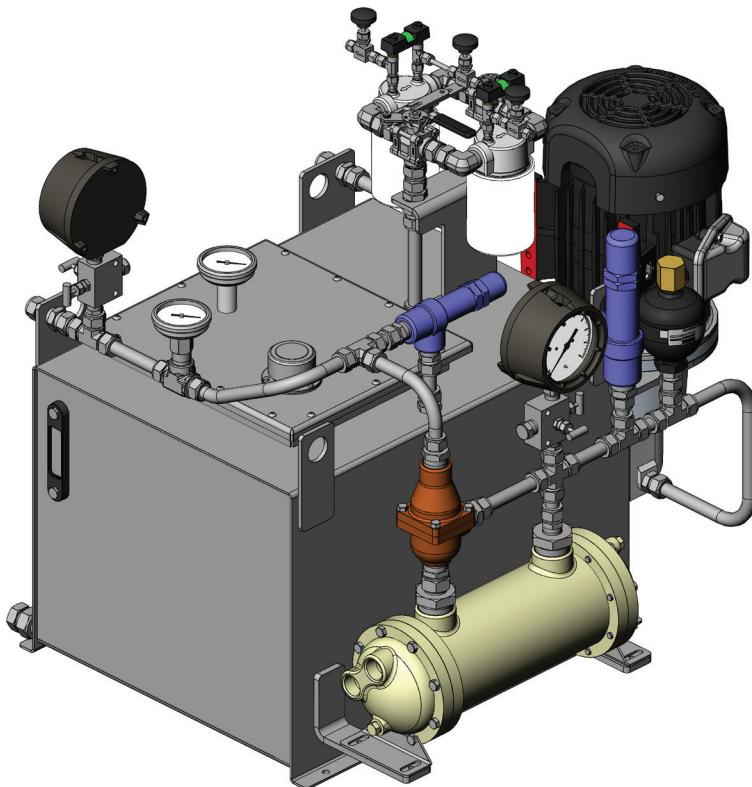

**Fig. 38 API Plan 55 Assembly**  
Assembly shown with some optional components.

*Assembly contents may include:*

- Swagelok tube fittings
- 63 series ball valves
- 1 series needle valve
- V series 2-valve manifold
- Bimetal thermometer
- TTW series thermowell tee
- Thermowell
- Hydraulic reservoir
- Swagelok pipe fittings
- Pump/coupling/motor
- Diaphragm accumulator
- Shell and tube head exchanger
- Thermostatic mixing valve
- Filter heads/elements
- Differential pressure indicators
- Suction strainer
- Flow/pressure control valves

See page 83 for additional information on individual components.

## API Plan 55 continued

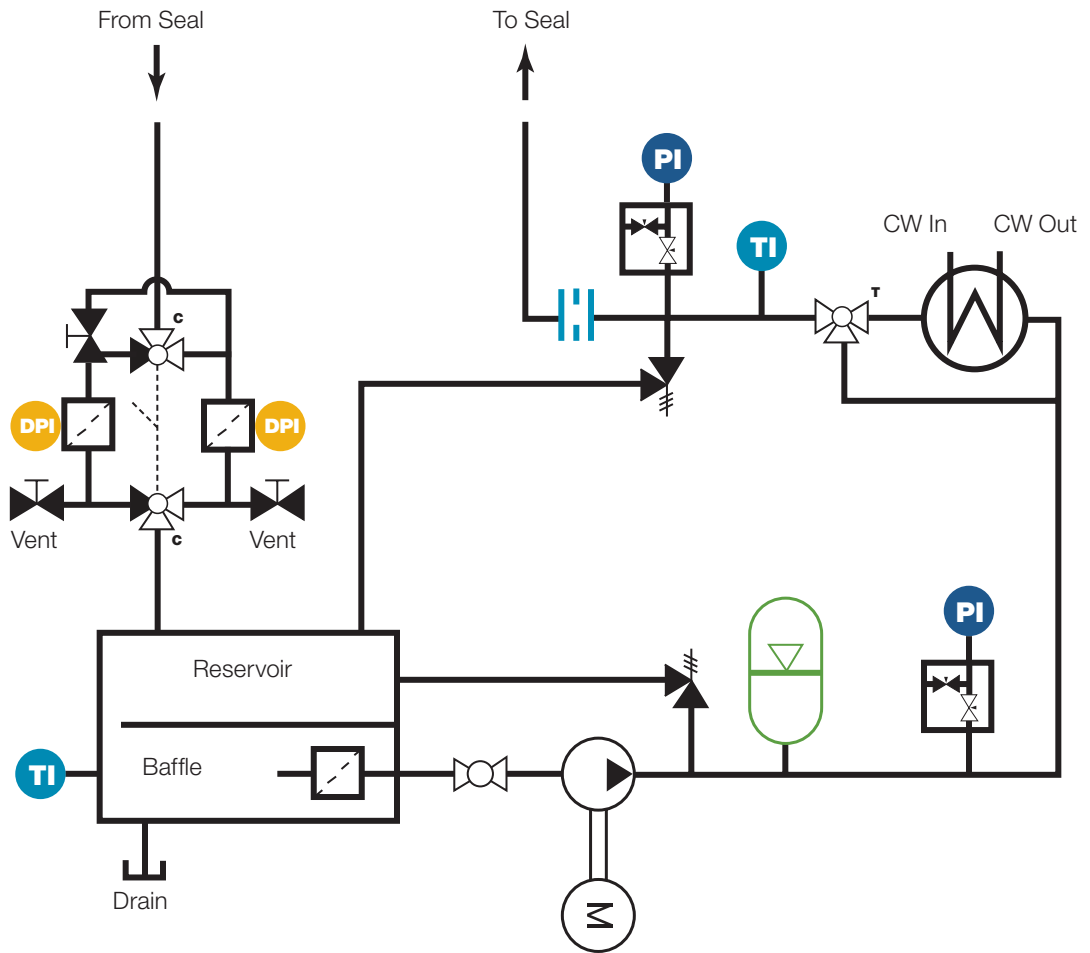

Fig. 39 Plan 55 P&amp;ID

Contact your authorized Swagelok sales and service center for information on optional components.



**API Plan 55 continued****Ordering Information**

Build an ordering number by combining the designators in the sequence shown below.

**Plan 55 Assembly**

SPA55 - **1** - **2** - **3** - **4** - **5** - **6** - **7** - **8**  
**D** - **05** **A** **2** **K** - **4** **B** **4**

**1 Primary Tubing Size**

**D** = 3/4 in.  
**L** = 18 mm

**2 Flow Capacity**

**05** = 5 gallons (18.9 liters) per minute  
**10** = 10 gallons (37.9 liters) per minute  
**15** = 15 gallons (56.8 liters) per minute

**3 Pump**

**A** = Single gear pump

**4 Cooling**

**1** = None  
**2** = Shell and tube exchanger

**5 Filtration**

**K** = Dual filters with switching valves and DP gauges

**6 Reservoir material**

**4** = 304 stainless steel  
**6** = 316 stainless steel

**7 Reservoir Level Measurement**

**B** = Sight gauge only

**8 Reservoir Temperature Measurement**

**1** = None  
**2** = Bimetal thermometer

## API Plan 55 continued

## Ordering Information

Build an ordering number by combining the designators in the sequence shown below.

## Plan 55 Field Installation Kit

The field installation kit contains tube fittings and tubing and may contain an optional bimetal thermometer, TTW series thermowell tee, V series 2-valve manifold, PGI series gauges, 63 series ball valves, pressure transmitters, and pipe nipples.

SPK55 - **1** - **2** - **3** - **4** - **5** - **6** - **7** - **8**  
 D - C 4 1 B - C 4 1

**1 Primary Tubing Size**

D = 3/4 in.  
 L = 18 mm

**2 Seal Connection (Barrier Inlet)**

B = 3/8 in. female NPT  
 C = 1/2 in. female NPT  
 D = 3/4 in. female NPT  
 H = G 3/8  
 J = G 1/2  
 K = G 3/4

**3 Seal Connector Type (Barrier Inlet)**

1 = Standard female connector<sup>①</sup>  
 2 = Standard male connector  
 3 = 4 in. extended male connector, hex  
 4 = 6 in. extended male connector, hex  
 5 = 4 in. extended male connector, machined  
 6 = 6 in. extended male connector, machined

<sup>①</sup> Installation will require use of pipe nipple (included in kit when female connector selected).

**4 Seal Connection Instrumentation (Barrier Inlet)**

1 = None  
 2 = Pressure gauge  
 3 = Pressure transmitter  
 4 = Thermometer  
 5 = Pressure gauge and thermometer  
 6 = Pressure transmitter and thermometer

**5 Seal Connection Drain (Barrier Inlet)**

A = None  
 C = Low point drain

**6 Seal Connection (Barrier Outlet)**

B = 3/8 in. female NPT  
 C = 1/2 in. female NPT  
 D = 3/4 in. female NPT  
 H = G 3/8  
 J = G 1/2  
 K = G 3/4

**7 Seal Connector Type (Barrier Outlet)**

1 = Standard female connector<sup>①</sup>  
 2 = Standard male connector  
 3 = 4 in. extended male connector, hex  
 4 = 6 in. extended male connector, hex  
 5 = 4 in. extended male connector, machined  
 6 = 6 in. extended male connector, machined

<sup>①</sup> Installation will require use of pipe nipple (included in kit when female connector selected).

**8 Seal Connection Instrumentation (Barrier Outlet)**

1 = None  
 2 = Pressure gauge  
 3 = Pressure transmitter  
 4 = Thermometer  
 5 = Pressure gauge and thermometer  
 6 = Pressure transmitter and thermometer

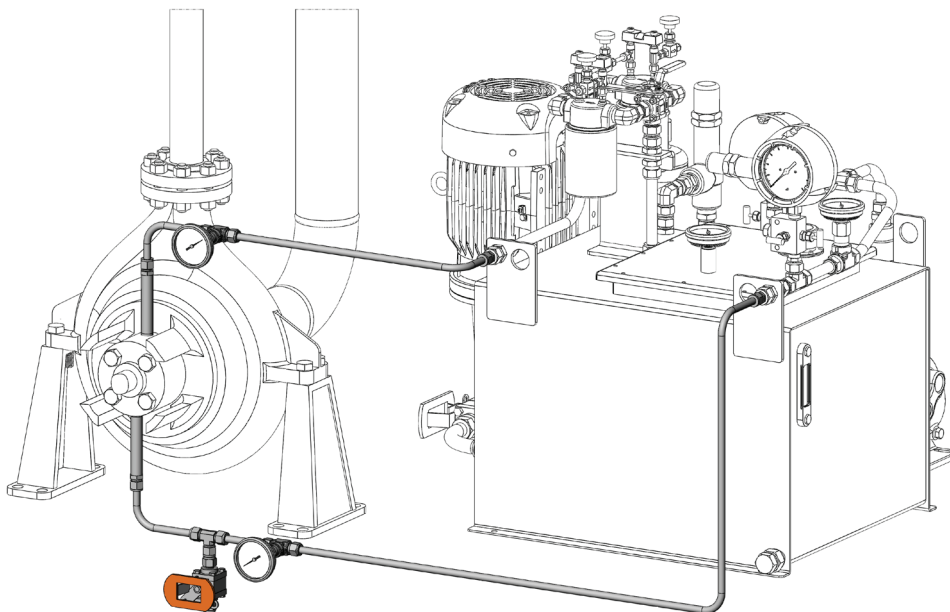

**Fig. 40 API Plan 55 Kit**  
 Kit contents shown solid and include optional components.

## API Plan 72 Buffer Gas

API Plan 72 supplies a buffer gas from an external source between the inboard and outboard seals. For reliable operation, gas seals require a constant supply of clean, dry gas, typically nitrogen. The seal support panel contains a coalescing filter to remove any moisture and particulate present in the supply of plant nitrogen. The clean, dry nitrogen dilutes process leakage from the inboard seal and sweeps it to a collection system. For condensing leakage, a Plan 75 is used as the collection system; for non-condensing leakage, a Plan 76 would be used for the collection of primary seal leakage. A pressure regulator on the panel regulates the nitrogen prior to entering the seal chamber. Nitrogen pressure should not be more than 10 psi (0.68 bar) and is typically regulated to the alarm point on the leakage collection system, or at least 5 psi (0.34 bar) above the regular pressure of the flare line.

### Plan 72

- Supplies the gas seal with a clean, dry buffer gas, typically nitrogen
- Serves as a containment seal in the event of inboard seal failure

Plan 72 is available as an assembled panel. The associated field installation kit for use in connecting the panel to your system is also available.

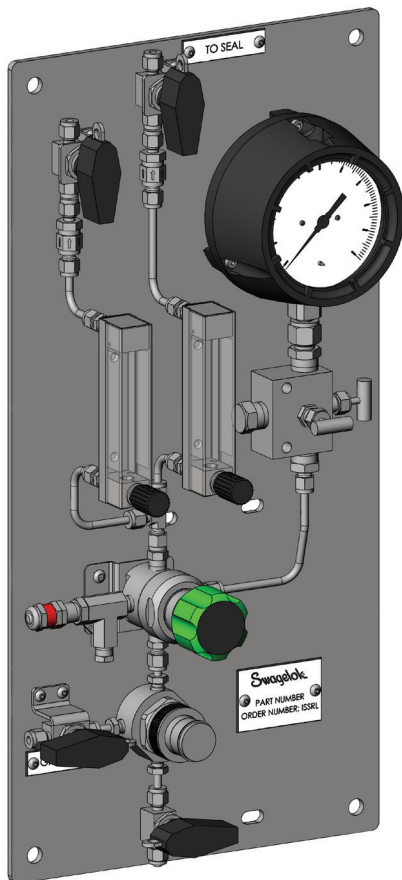

**Fig. 41 API Plan 72 Panel**

Panel shown with some optional components.

### Panel contents may include:

- Swagelok tube fittings
- 43G series ball valves
- V series 2-valve manifold
- R series relief valves
- CH series check valves
- FC series filter
- G2, M1, and M2 model flowmeters
- KPR series regulator
- PGI series gauges
- Swagelok pipe fittings
- Pressure transmitter
- Pressure switch
- Mounting panel
- Brackets/miscellaneous hardware

See page 83 for additional information on individual components.

## API Plan 72 continued

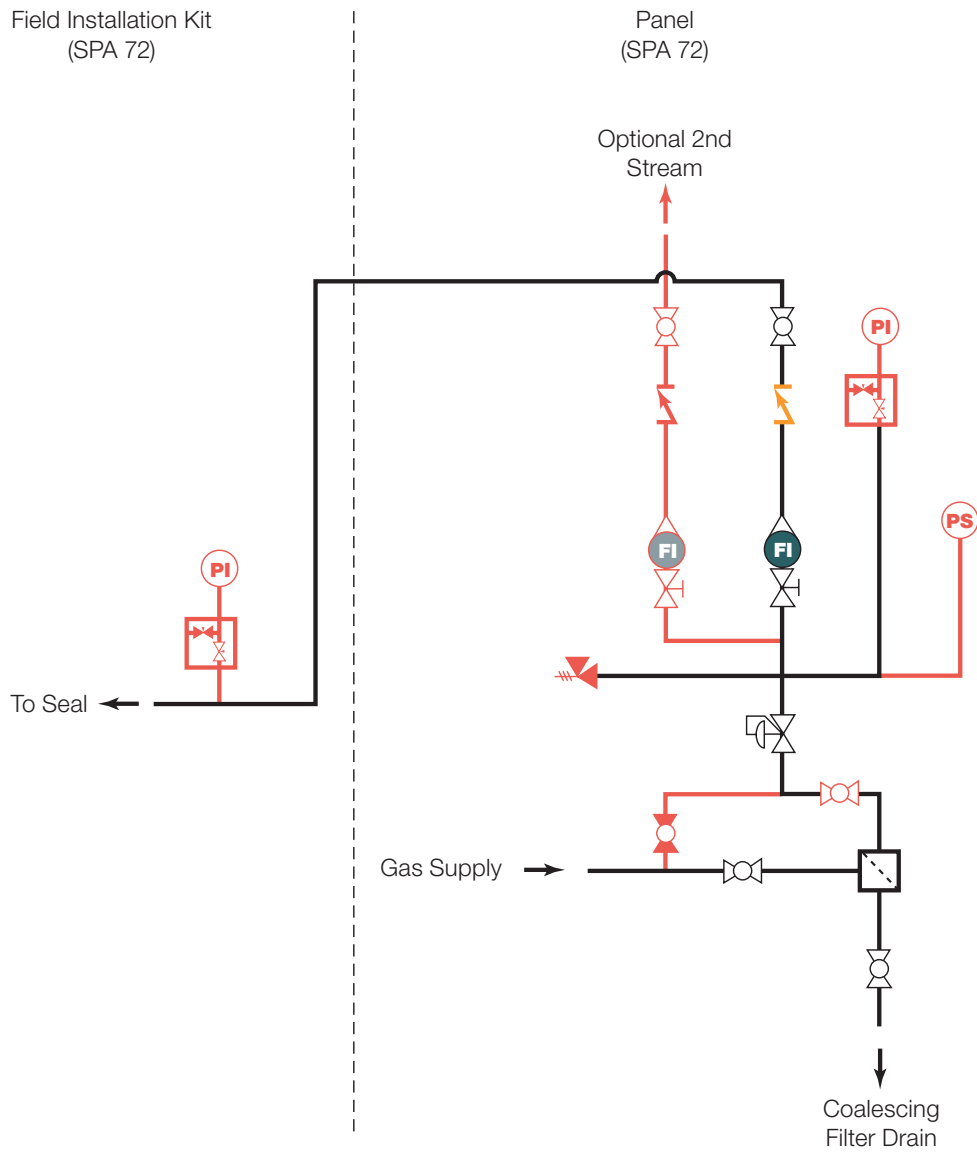

**Fig. 42 Plan 72 P&ID**  
Optional components shown in red.

Contact your authorized Swagelok sales and service center for information on optional components.

**API Plan 72 continued****Ordering Information**

Build an ordering number by combining the designators in the sequence shown below.

**Plan 72 Panel**

SPA72 - **1** - **2** - **3** - **4** - **5** - **6**  
**A** - **A** **2** **B** **1** - **M1**

**1 Primary Tubing Size**

**A** = 1/4 in.  
**G** = 6 mm

**2 Filtration Options**

**A** = No options (filter only)  
**B** = Shut-off valves  
**C** = Manual bypass valves

**3 Instrumentation Options**

**2** = Pressure gauge  
**3** = Pressure transmitter  
**7** = Pressure switch  
**8** = Pressure gauge and switch

**4 Flowmeter Options**

**A** = G2 series variable area flowmeter  
**C** = M1 series variable area flowmeter  
**E** = M2 series variable area flowmeter

**5 Number of Streams**

**1** = One stream  
**2** = Two streams

**6 Additional Options**

**M1** = Alloy 400 outlet(s)  
**R** = Relief valve  
**Blank** = None

**API Plan 72 continued****Ordering Information**

Build an ordering number by combining the designators in the sequence shown below.

**Plan 72 Field Installation Kit**

The field installation kit contains tube fittings and tubing and may contain optional PGI series gauges, V series 2-valve manifolds, pipe fittings, pressure transmitters, and pipe nipples.

SPK72 - **1** - **2** - **3** - **4** - **2**  
**C** - **C** **4** **2**

**1 Primary Tubing Size**

**C** = 1/2 in.  
**K** = 12 mm

**2 Seal Connection (Gas Buffer Inlet)**

**B** = 3/8 in. female NPT  
**C** = 1/2 in. female NPT  
**D** = 3/4 in. female NPT  
**H** = G 3/8  
**J** = G 1/2  
**K** = G 3/4

**3 Seal Connector Type (Gas Buffer Inlet)**

**1** = Standard female connector<sup>①</sup>  
**2** = Standard male connector  
**3** = 4 in. extended male connector, hex  
**4** = 6 in. extended male connector, hex  
**5** = 4 in. extended male connector, machined  
**6** = 6 in. extended male connector, machined

<sup>①</sup> Installation will require use of pipe nipple (included in kit when female connector selected).

**4 Seal Connection Instrumentation (Gas Buffer Inlet)**

**1** = None  
**2** = Pressure gauge  
**3** = Pressure transmitter

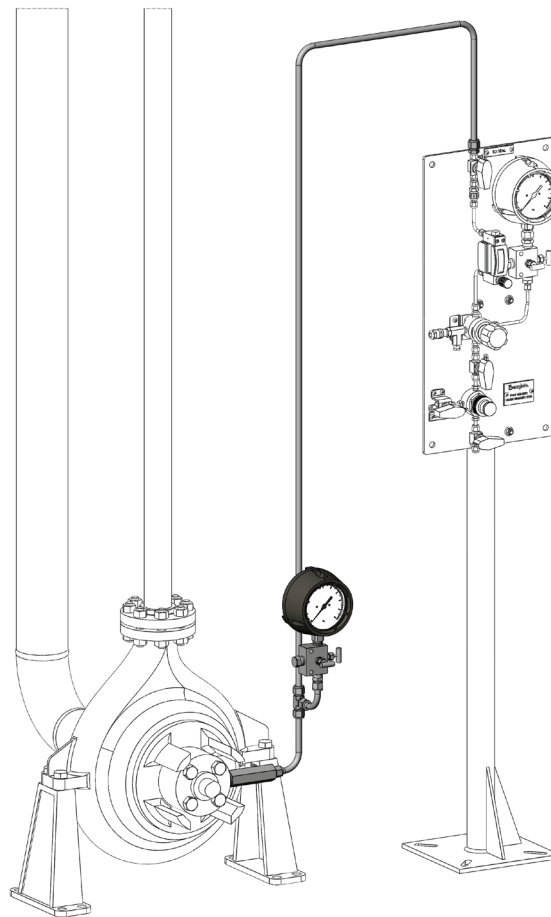

**Fig. 43 API Plan 72 Kit**  
 Kit contents shown solid and include optional components.

## API Plan 74 Barrier Gas

API Plan 74 supplies a pressurized barrier gas from an external source between the inboard and outboard seals. For reliable operation, dual pressurized gas seals require a constant supply of clean, dry gas, typically nitrogen. The seal support panel contains a coalescing filter to remove any moisture and particulate present in the supply of plant nitrogen. A pressure regulator on the panel regulates the nitrogen to at least 25 psi (1.7 bar) above the seal chamber. Used in applications where process leakage cannot be tolerated, the system is designed to allow a small amount of nitrogen to leak into the process fluid. Any leakage past the outboard seal will be pure nitrogen. An optional flow transmitter located on the gas supply panel monitors excessive leakage in the event of a seal failure.

### Plan 74

- Supplies the gas seal with a clean, dry buffer gas, typically nitrogen
- Prevents process leakage to atmosphere in the event of a inboard or outboard seal failure

Plan 74 is available as an assembled panel. The associated field installation kit for use in connecting the panel to your system is also available.

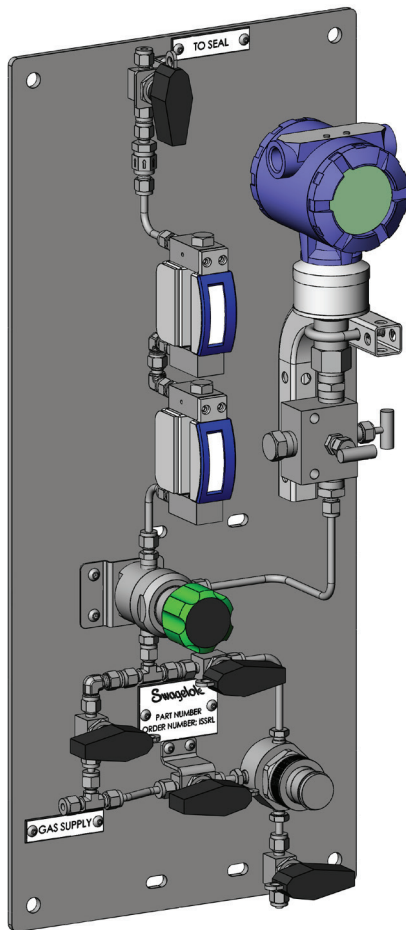

### Panel contents may include:

- Swagelok tube fittings
- 43G series ball valves
- V series 2-valve manifold
- R series relief valves
- CH series check valves
- FC series filter
- G2, M1, and M2 model flowmeters
- KPR series regulator
- PGI series gauges
- Swagelok pipe fittings
- Pressure transmitter
- Pressure switch
- Mounting panel
- Brackets/miscellaneous hardware

See page 83 for additional information on individual components.

**Fig. 44 API Plan 74 Panel**

Panel shown with some optional components.

## API Plan 74 continued

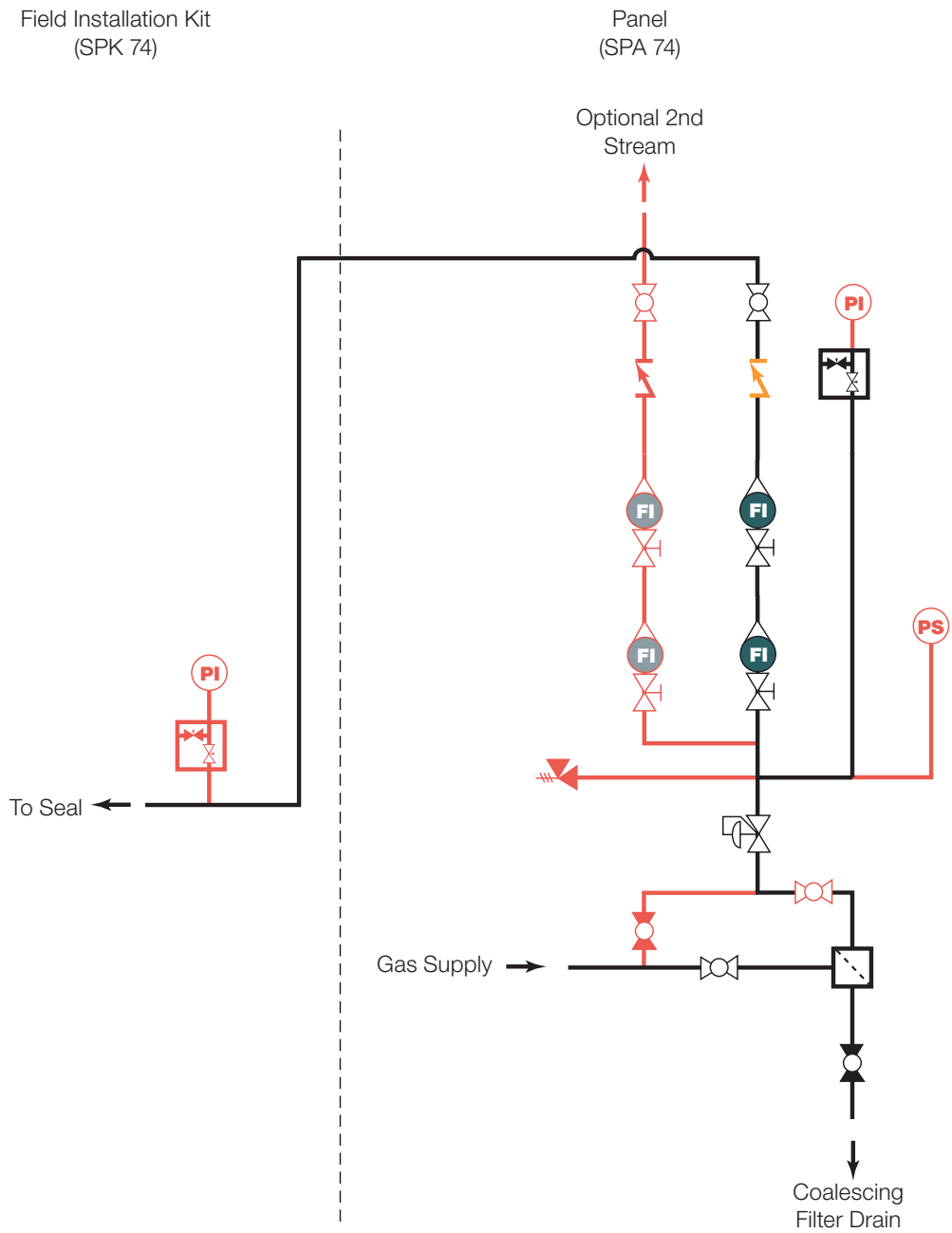

**Fig. 45 Plan 74 P&ID**  
Optional components shown in red.

Contact your authorized Swagelok sales and service center for information on optional components.



**API Plan 74 continued****Ordering Information**

Build an ordering number by combining the designators in the sequence shown below.

**Plan 74 Panel**

SPA74 - **1** - **2** - **3** - **4** - **5** - **6**  
**A** - **A** **2** **B** **1** - **M1**

**1 Primary Tubing Size**

**A** = 1/4 in.  
**G** = 6 mm

**2 Filtration Options**

**A** = No options (filter only)  
**B** = Shut-off valves  
**C** = Manual bypass valves

**3 Instrumentation Options**

**2** = Pressure gauge  
**3** = Pressure transmitter  
**7** = Pressure switch  
**8** = Pressure gauge and switch

**4 Flowmeter Options**

**B** = Dual G2 series variable area flowmeters  
**D** = Dual M1 series variable area flowmeters  
**F** = Dual M2 series variable area flowmeters

**5 Number of Streams**

**1** = One stream  
**2** = Two streams

**6 Additional Options**

**M1** = Alloy 400 outlet(s)  
**R** = Relief valve  
**Blank** = None

**API Plan 74 continued****Ordering Information**

Build an ordering number by combining the designators in the sequence shown below.

**Plan 74 Field Installation Kit**

The field installation kit contains tube fittings and tubing and may contain optional PGI series gauges, V series 2-valve manifolds, pipe fittings, pressure transmitters, and pipe nipples.

SPK74 - **1** - **2** **3** **4** **2**

**1 Primary Tubing Size**

**C** = 1/2 in.  
**K** = 12 mm

**2 Seal Connection (Gas Barrier Inlet)**

**B** = 3/8 in. female NPT  
**C** = 1/2 in. female NPT  
**D** = 3/4 in. female NPT  
**H** = G 3/8  
**J** = G 1/2  
**K** = G 3/4

**3 Seal Connector Type (Gas Barrier Inlet)**

**1** = Standard female connector<sup>①</sup>  
**2** = Standard male connector  
**3** = 4 in. extended male connector, hex  
**4** = 6 in. extended male connector, hex  
**5** = 4 in. extended male connector, machined  
**6** = 6 in. extended male connector, machined  
<sup>①</sup> Installation will require use of pipe nipple (included in kit when female connector selected).

**4 Seal Connection Instrumentation (Gas Barrier Inlet)**

**1** = None  
**2** = Pressure gauge  
**3** = Pressure transmitter

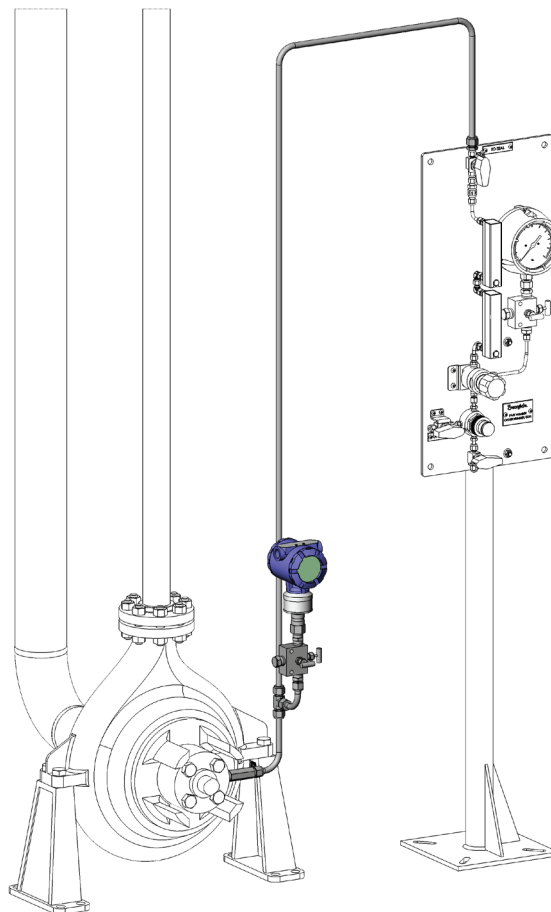

**Fig. 46 API Plan 74 Kit**  
Kit contents shown solid and include optional components.

## API Plan 75 Condensing Leakage Collection

API Plan 75 collects leakage from the inboard seal in applications where normal process fluid leakage can condense between the seals at ambient temperatures. In this arrangement, a reservoir is connected to the containment seal drain port on the gland. Condensed leakage from the inner seal is collected in the reservoir while vapor is routed to the flare system. Excessive liquid inner seal leakage is detected by a level transmitter, while excessive gaseous leakage is detected by a pressure transmitter situated prior to an orifice on the tubing connected to the flare. A visual level indicator on the reservoir indicates when the reservoir needs to be drained.

### Plan 75

- Collects and monitors inboard seal leakage that condenses at ambient temperatures
- Is typically used in conjunction with a Plan 72

Plan 75 is available as an assembled collection vessel. The associated field installation kit for use in connecting the collection vessel to your system is also available.

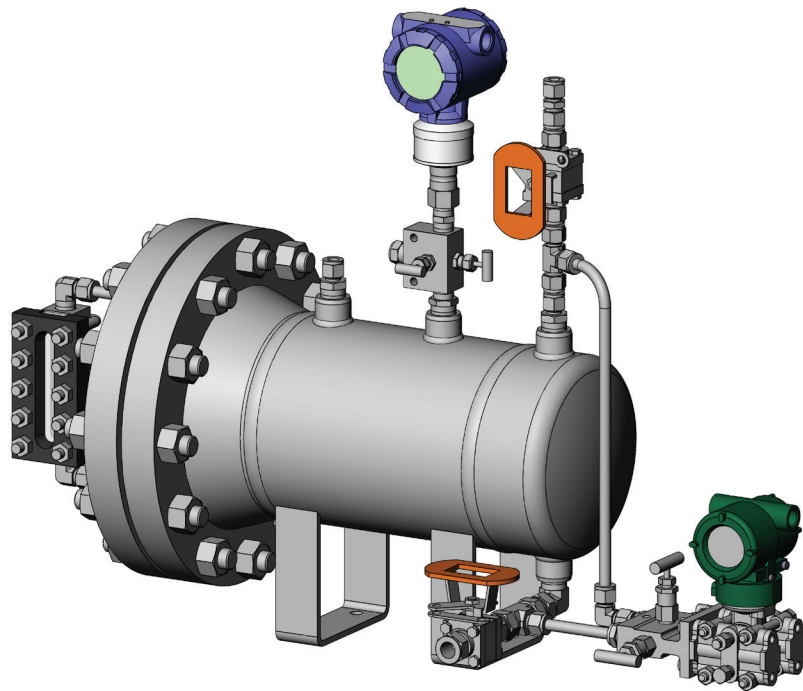

**Fig. 47 API Plan 75 Collection Vessel**  
Assembly shown with some optional components.

*Collection vessel contents may include:*

- Swagelok tube fittings
- 63 series ball valves
- V series 2-valve manifold
- PGI series gauges
- Swagelok pipe fittings
- Pressure transmitter
- Level transmitter
- Level gauge
- Collection reservoir

See page 83 for additional information on individual components.

## API Plan 75 continued

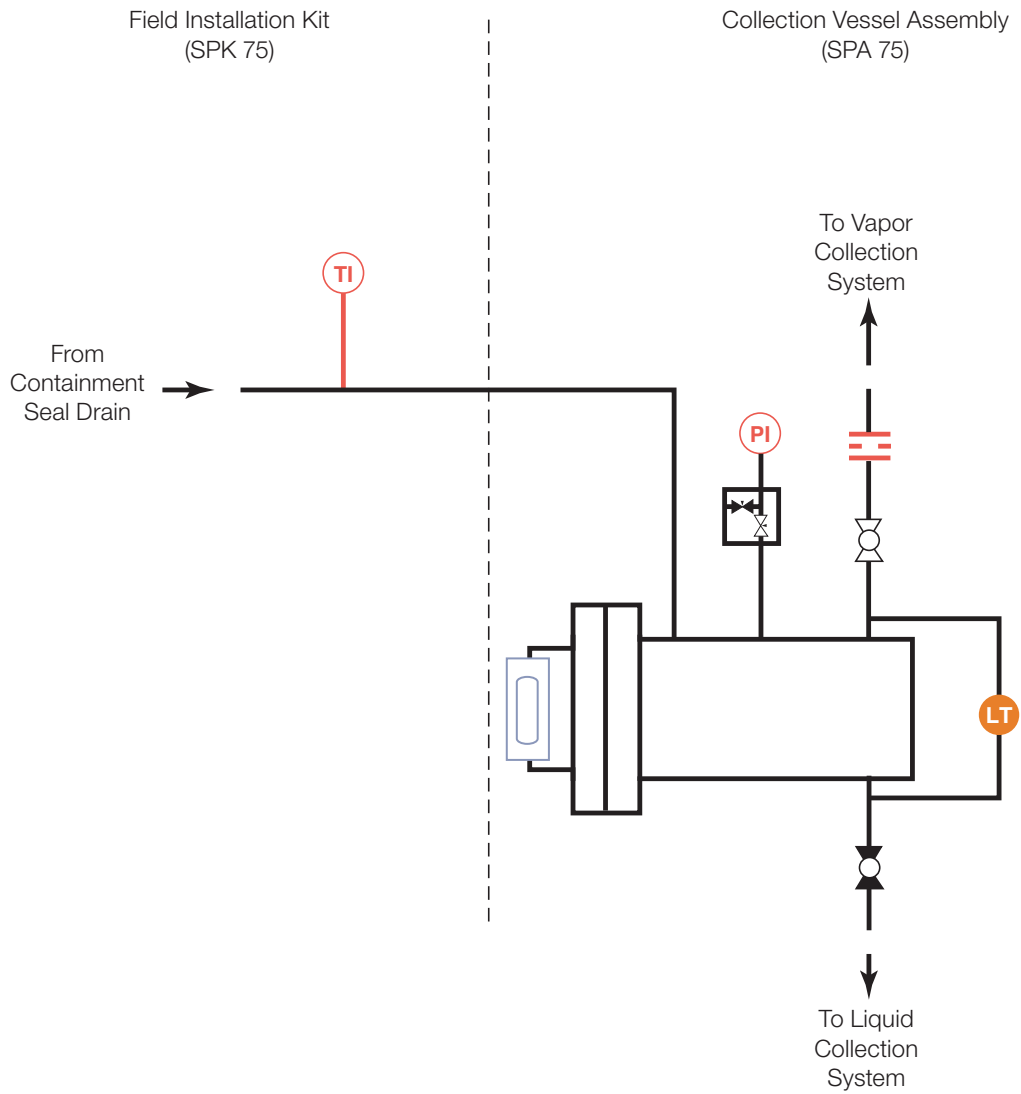

**Fig. 48 Plan 75 P&ID**  
Optional components shown in red.

Contact your authorized Swagelok sales and service center for information on optional components.

**API Plan 75 continued****Ordering Information**

Build an ordering number by combining the designators in the sequence shown below.

**Plan 75 Collection Vessel**

SPA75 - <sup>1</sup>C - <sup>2</sup>15 <sup>3</sup>U <sup>4</sup>4 <sup>5</sup>D <sup>6</sup>3 <sup>7</sup>C

**1 Primary Tubing Size**

C = 1/2 in.  
K = 12 mm

**2 Reservoir Capacity**

15 = 15 liters (4 gallons)

**3 Reservoir Code**

N = None  
P = Pressure Equipment Directive (PED)  
U = ASME

**4 Reservoir Material**

S = Carbon steel (painted)  
4 = 304 stainless steel  
6 = 316 stainless steel

**5 Reservoir Level Measurement**

D = Sight gauge with level transmitter

**6 Reservoir Pressure Measurement**

2 = Pressure gauge  
3 = Pressure transmitter

**7 Reservoir Orifice**

A = None  
B = Swagelok tube fitting union  
C = Integral to flange adapter

**API Plan 75 continued****Ordering Information**

Build an ordering number by combining the designators in the sequence shown below.

**Plan 75 Field Installation Kit**

The field installation kit contains tube fittings and tubing and may contain an optional bimetal thermometer, TTW series thermowell tee, and pipe nipple.

**Plan 75 Kit**

SPK75 - **1** - **2** **3** **4**  
**C** - **C** **4** **1**

**1 Primary Tubing Size**

**C** = 1/2 in.  
**K** = 12 mm

**2 Seal Connection (Drain)**

**B** = 3/8 in. female NPT  
**C** = 1/2 in. female NPT  
**D** = 3/4 in. female NPT  
**H** = G 3/8  
**J** = G 1/2  
**K** = G 3/4

**3 Seal Connector Type (Drain)**

**1** = Standard female connector<sup>①</sup>  
**2** = Standard male connector  
**3** = 4 in. extended male connector, hex  
**4** = 6 in. extended male connector, hex  
**5** = 4 in. extended male connector, machined  
**6** = 6 in. extended male connector, machined

<sup>①</sup> Installation will require use of pipe nipple (included in kit when female connector selected).

**4 Seal Connection Instrumentation (Drain)**

**1** = None  
**4** = Thermometer

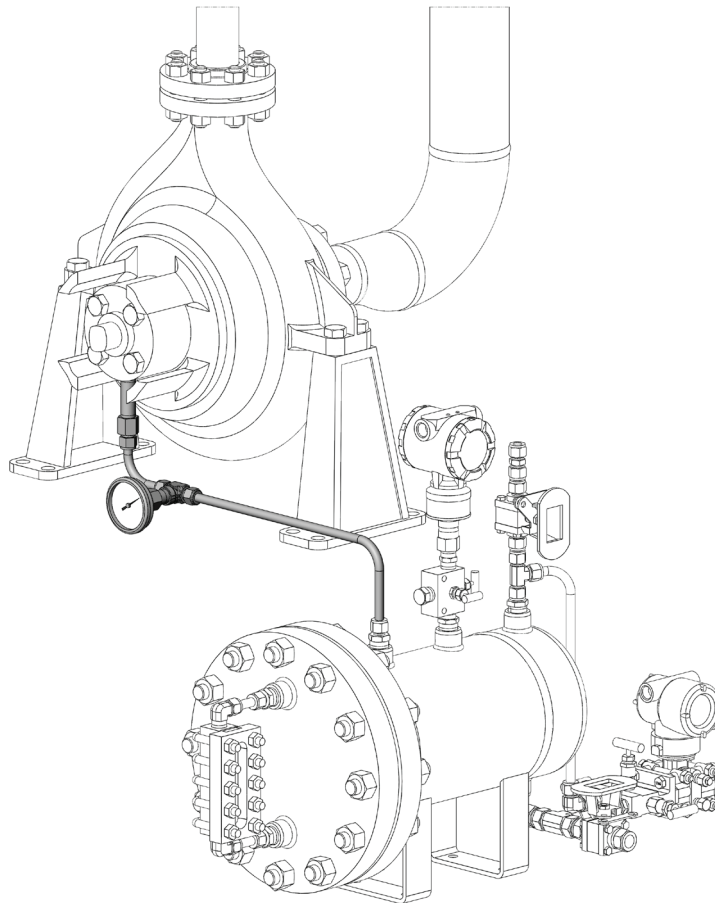

**Fig. 49 API Plan 75 Kit**  
 Kit contents shown solid and include optional components.

## API Plan 76 Noncondensing Leakage Collection

API Plan 76 collects leakage from the inboard seal in applications where normal process fluid leakage does not condense between the seals at ambient temperatures. In this piping plan, gaseous leakage from the inboard seal exits through the containment seal vent port in the gland. The orifice creates the necessary back-pressure for a pressure transmitter to signal an alarm in the event of a seal failure.

### Plan 76

- Monitors inboard seal leakage that does not condense at ambient temperatures
- Is typically used in conjunction with a Plan 72

Plan 76 is available as an assembled panel. The associated field installation kit for use in connecting the panel to your system is also available.

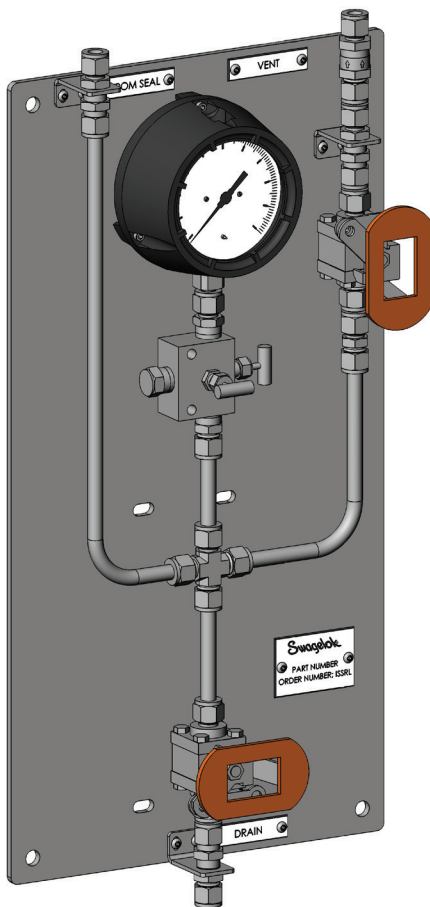

**Fig. 50 API Plan 76 Panel**

Panel shown with some optional components.

*Panel contents may include:*

- Swagelok tube fittings
- 63 series ball valves
- V series 2-valve manifold
- CH series check valves
- PGI series gauges
- Swagelok pipe fittings
- Pressure transmitter
- Pressure switch
- Mounting panel
- Brackets/miscellaneous hardware

See page 83 for additional information on individual components.

## API Plan 76 continued

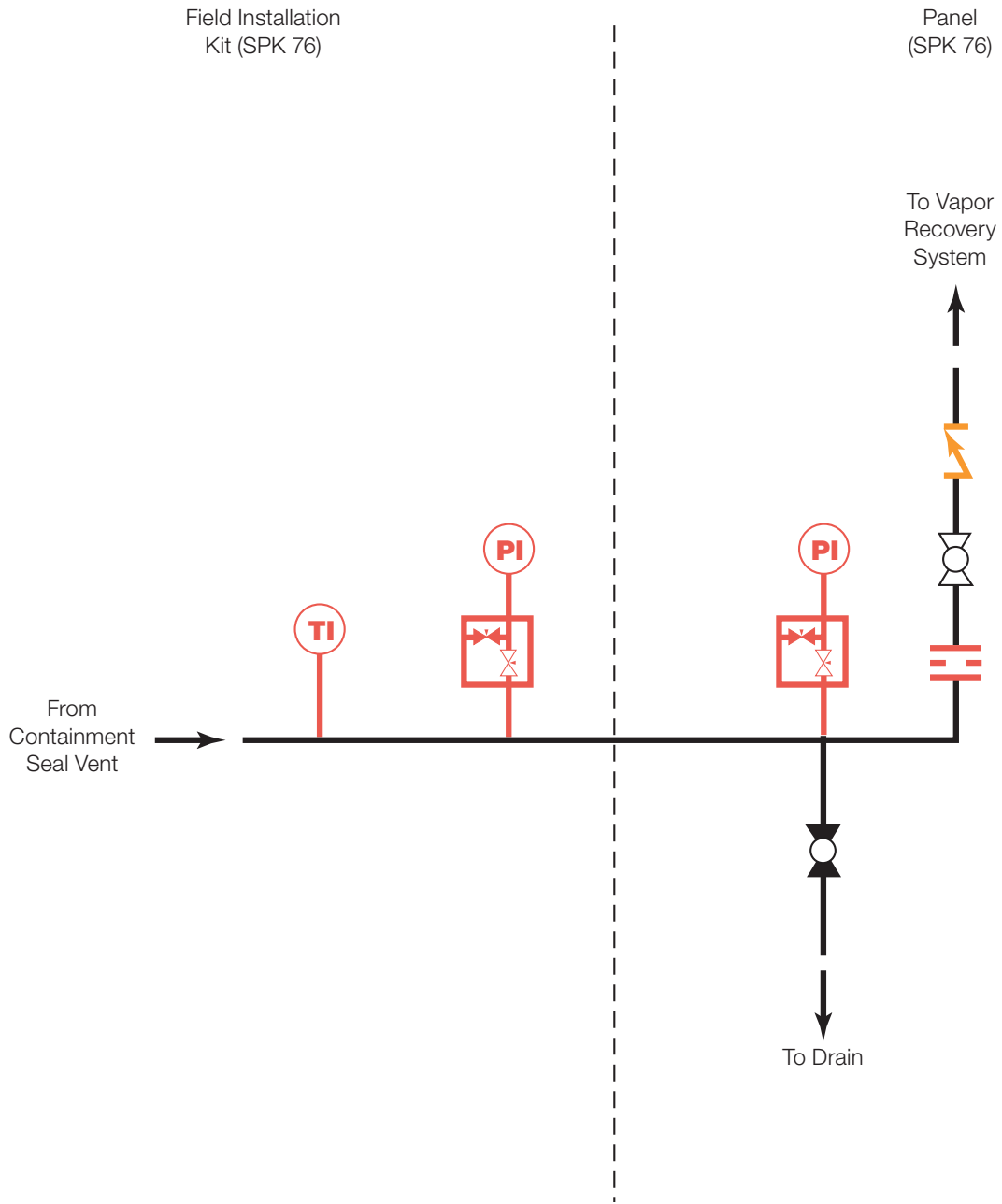

**Fig. 51 Plan 76 P&ID**  
Optional components shown in red.

Contact your authorized Swagelok sales and service center for information on optional components.



## API Plan 76 continued

### Ordering Information

Build an ordering number by combining the designators in the sequence shown below.

#### Plan 76 Panel

SPA76 - <sup>1</sup>**C** - <sup>2</sup>**2** <sup>3</sup>**A** - <sup>4</sup>**M1**

**1 Primary Tubing Size**

**C** = 1/2 in.  
**K** = 12 mm

**2 Instrumentation**

**2** = Pressure gauge  
**3** = Pressure transmitter  
**7** = Pressure switch

**3 Orifice**

**A** = None  
**B** = Swagelok tube fitting union

**4 Other options**

**M1** = Alloy 400 outlet  
**Omit** = none

**API Plan 76 continued****Ordering Information**

Build an ordering number by combining the designators in the sequence shown below.

**Plan 76 Field Installation Kit**

The field installation kit contains tube fittings and tubing and may contain an optional bimetal thermometer, TTW series thermowell tee, and pipe nipple.

**Plan 76 Kit**

SPK76 - **1** - **2** **3** **4**  
**C** - **C** **4** **1**

**1 Primary Tubing Size**

**C** = 1/2 in.  
**K** = 12 mm

**2 Seal Connection (Vent)**

**B** = 3/8 in. female NPT  
**C** = 1/2 in. female NPT  
**D** = 3/4 in. female NPT  
**H** = G 3/8  
**J** = G 1/2  
**K** = G 3/4

**3 Seal Connector Type (Vent)**

**1** = Standard female connector<sup>①</sup>  
**2** = Standard male connector  
**3** = 4 in. extended male connector, hex  
**4** = 6 in. extended male connector, hex  
**5** = 4 in. extended male connector, machined  
**6** = 6 in. extended male connector, machined

<sup>①</sup> Installation will require use of pipe nipple (included in kit when female connector selected).

**4 Seal Connection Instrumentation (Vent)**

**1** = None  
**2** = Pressure gauge  
**3** = Pressure transmitter  
**4** = Thermometer  
**5** = Pressure gauge and thermometer  
**6** = Pressure transmitter and thermometer

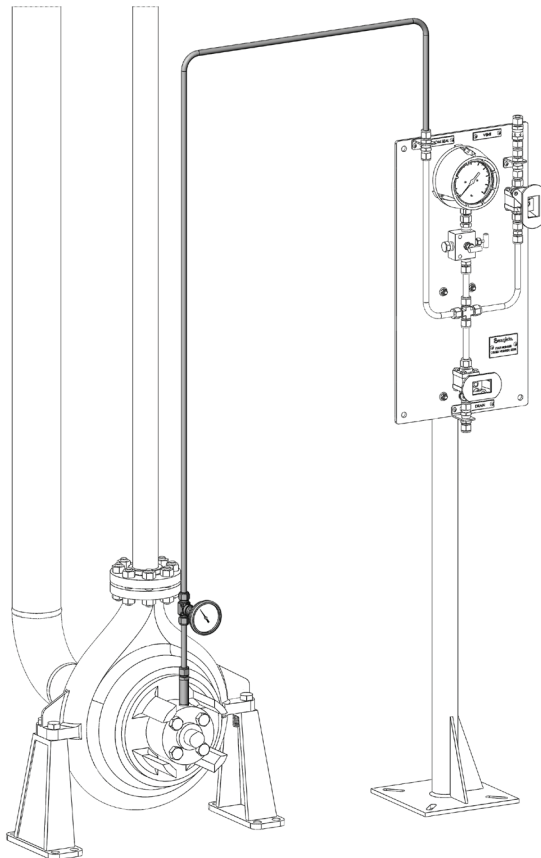

**Fig. 52 API Plan 76 Kit**  
 Kit contents shown solid and include optional components.

## API Plan 72/76 Buffer Gas and Noncondensing Leakage Collection

This panel is a combination of API Plan 72 and Plan 76. The Plan 72 side supplies a buffer gas from an external source between the inboard and outboard faces of a dual seal. For reliable operation, gas seals require a constant supply of clean, dry gas, typically nitrogen. The seal support panel contains a coalescing filter to remove any moisture and particulate present in the supply of plant nitrogen. The clean, dry nitrogen dilutes process leakage from the inboard seal and sweeps it to a collection system. The Plan 76 side collects the primary seal leakage. A pressure regulator on the panel regulates the nitrogen prior to entering the seal chamber. Nitrogen pressure should not be more than 10 psi (0.68 bar) and is typically regulated to the alarm point on the leakage collection system, or at least 5 psi (0.34 bar) above the regular pressure of the flare line.

### Plan 72/76

- Supplies the gas seal with a clean, dry buffer gas, typically nitrogen
- Serves as a containment seal in the event of primary seal failure
- Monitors inner seal leakage that does not condense at ambient temperatures

Plan 72/76 is available as an assembled panel. The associated field installation kit for use in connecting the panel to your system is also available.

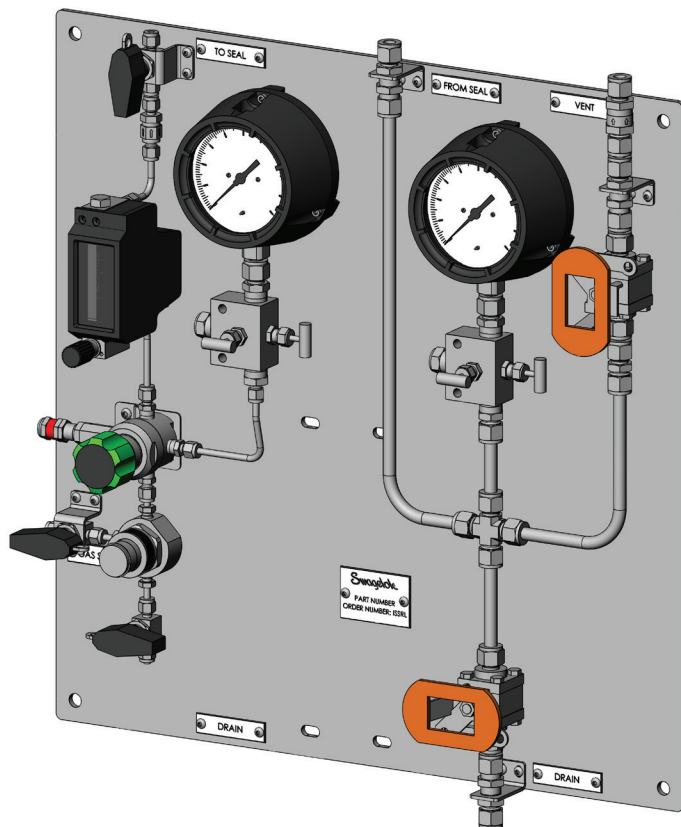

**Fig. 53 API Plan 72/76 Panel**  
Panel shown with some optional components.

### Panel contents may include:

- Swagelok tube fittings
- 43G series ball valves
- V series 2-valve manifold
- R series relief valves
- CH series check valves
- FC series filter
- G2, M1, and M2 model flowmeters
- KPR series regulator
- PGI series gauges
- Swagelok pipe fittings
- Pressure transmitter
- Pressure switch
- Mounting panel
- Brackets/miscellaneous hardware

See page 83 for additional information on individual components.

API Plan 72/76 continued

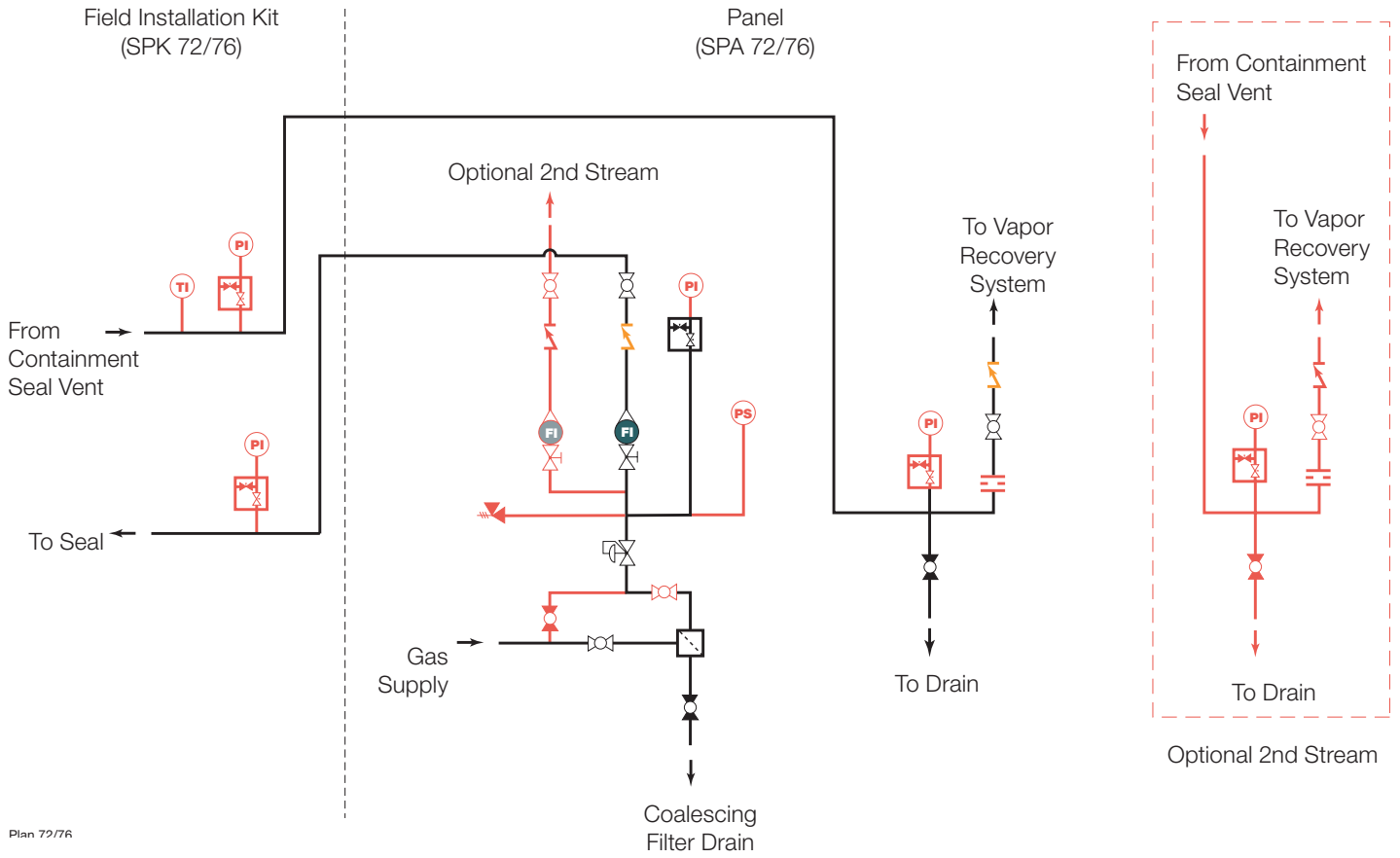

Plan 72/76

**Fig. 54 Plan 72/76 P&ID**  
Optional components shown in red.

Contact your authorized Swagelok sales and service center for information on optional components.

**API Plan 72/76 continued****Ordering Information**

Build an ordering number by combining the designators in the sequence shown below.

**Plan 72/76 Panel**

SPA726 - **1** **2** **3** **4** **5** - **6** **7** **8** **9**  
**A A 2 B 1 - C 2 B- R**

**Plan 72****1 Primary Tubing Size**

**A** = 1/4 in.  
**G** = 6 mm

**2 Filtration Options**

**A** = No options (filter only)  
**B** = Shut-off valves  
**C** = Manual bypass valves

**3 Instrumentation Options**

**2** = Pressure gauge  
**3** = Pressure transmitter  
**7** = Pressure switch  
**8** = Pressure gauge and switch

**4 Flowmeter Options**

**B** = Dual G2 series variable area flowmeters  
**D** = Dual M1 series variable area flowmeters  
**F** = Dual M2 series variable area flowmeters

**5 Number of Streams**

**1** = One stream  
**2** = Two streams

**Plan 76****6 Primary Tubing Size**

**C** = 1/2 in.  
**K** = 12 mm

**7 Instrumentation Options**

**2** = Pressure gauge  
**3** = Pressure transmitter  
**7** = Pressure switch

**8 Orifice**

**A** = None  
**B** = Tube fitting union

**9 Additional Options**

**M1** = Alloy 400 outlet(s)  
**R** = Relief valve  
**Blank** = None

## API Plan 72/76 continued

## Ordering Information

Build an ordering number by combining the designators in the sequence shown below.

## Plan 72/76 Field Installation Kit

The field installation kit contains tube fittings and tubing and may contain optional PGI series gauges, V series 2-valve manifolds, pipe fittings, pressure transmitters, and pipe nipples.

SPK726 - **1** **2** **3** **4** - **5** **6** **7**  
**C** - **C** **4** **2** - **C** **4** **2**

**1 Primary Tubing Size**

- C** = 1/2 in.
- K** = 12 mm

**2 Seal Connection (Gas Buffer Inlet)**

- B** = 3/8 in. female NPT
- C** = 1/2 in. female NPT
- D** = 3/4 in. female NPT
- H** = G 3/8
- J** = G 1/2
- K** = G 3/4

**3 Seal Connector Type (Gas Buffer Inlet)**

- 1** = Standard female connector<sup>①</sup>
- 2** = Standard male connector
- 3** = 4 in. extended male connector, hex
- 4** = 6 in. extended male connector, hex
- 5** = 4 in. extended male connector, machined
- 6** = 6 in. extended male connector, machined

<sup>①</sup> Installation will require use of pipe nipple (included in kit when female connector selected).

**4 Instrumentation (Gas Buffer Inlet)**

- 1** = None
- 2** = Pressure gauge
- 3** = Pressure transmitter

**5 Seal Connection (Vent)**

- B** = 3/8 in. female NPT
- C** = 1/2 in. female NPT
- D** = 3/4 in. female NPT
- H** = G 3/8
- J** = G 1/2
- K** = G 3/4

**6 Seal Connector Type (Vent)**

- 1** = Standard female connector<sup>①</sup>
- 2** = Standard male connector
- 3** = 4 in. extended male connector, hex
- 4** = 6 in. extended male connector, hex
- 5** = 4 in. extended male connector, machined
- 6** = 6 in. extended male connector, machined

<sup>①</sup> Installation will require use of pipe nipple (included in kit when female connector selected).

**7 Instrumentation (Vent)**

- 1** = None
- 2** = Pressure gauge
- 3** = Pressure transmitter
- 4** = Thermometer
- 5** = Pressure gauge and thermometer
- 6** = Pressure transmitter and thermometer

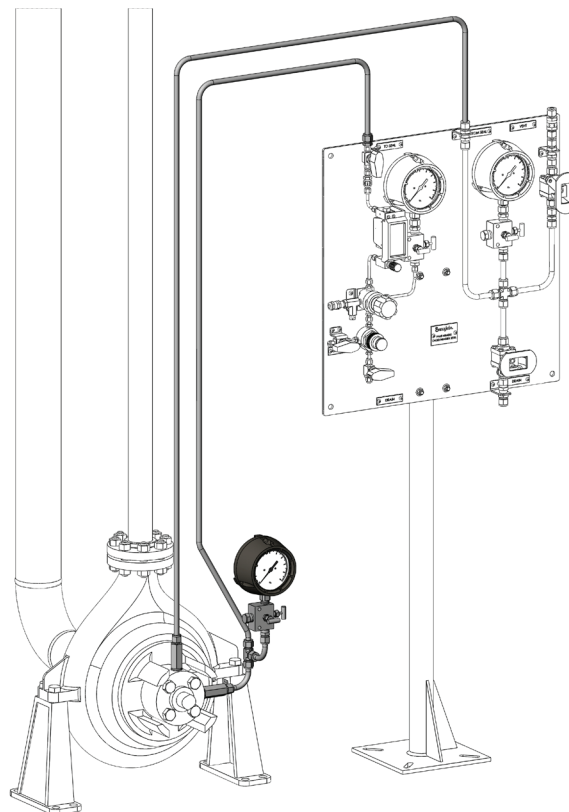

**Fig. 55 API Plan 72/76 Kit**  
 Kit contents shown solid and include optional components.

## Atmospheric Side Plans

### API Plan 51 Quench from Reservoir

API Plan 51 is a quench system for use on the atmospheric side of a single seal. This system acts as a dead-ended reservoir for a fluid.

Plan 51

- Prevents icing on the atmospheric side of the seal
- Is typically used on vertical pumps

Plan 51 is available as a kit of components ready for field assembly.

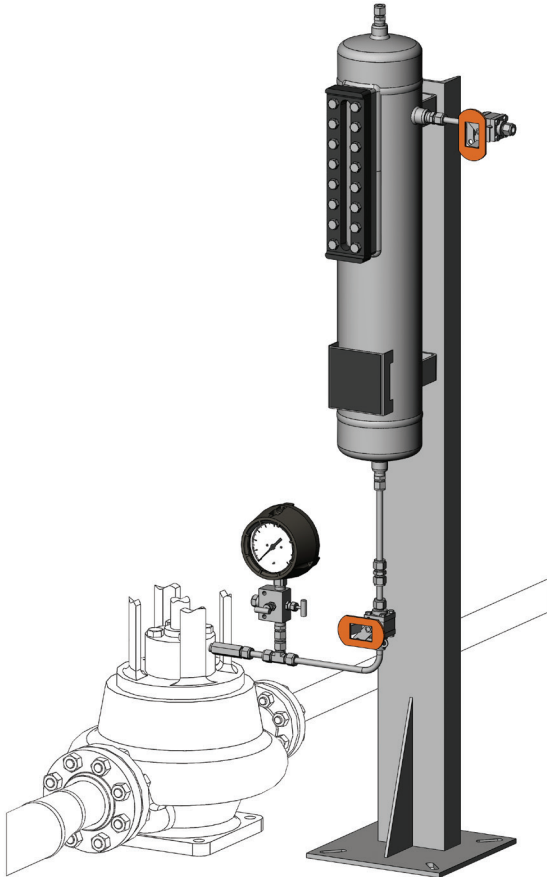

**Fig. 56 API Plan 51**

Kit contents shown solid and include some optional components.

*Kit contents may include:*

- Swagelok tube fittings
- V series 2-valve manifold
- 63 series ball valves
- PGI series gauges
- Swagelok pipe fittings
- Swagelok flange adapters
- Pressure transmitter
- Flange gasket
- Flange studs/nuts
- Buffer fluid reservoir
- Pipe nipple

See page 83 for additional information on individual components.

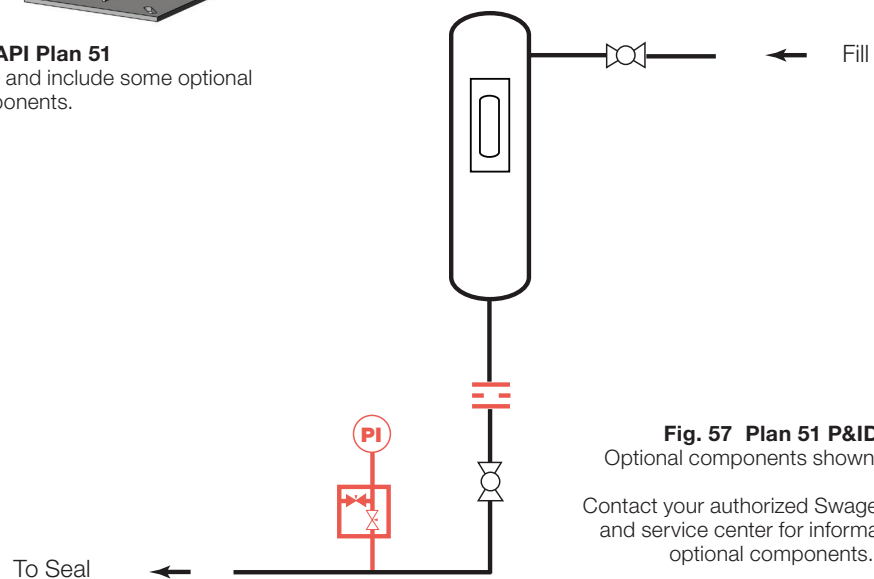

**Fig. 57 Plan 51 P&ID**

Optional components shown in red.

Contact your authorized Swagelok sales and service center for information on optional components.

**API Plan 51 continued****Ordering Information**

Build an ordering number by combining the designators in the sequence shown below.

**Plan 51 Kit**

SPK51 - **1** - **2** **3** **4** **5** - **6** **7** **8** **9** **10**  
**C** - **C** **4** **1** **B** - **12** **N** **4** **3** **B**

**1 Primary Tubing Size**

**C** = 1/2 in.

**K** = 12 mm

**2 Seal Connection (Quench)**

**B** = 3/8 in. female NPT

**C** = 1/2 in. female NPT

**H** = G 3/8

**J** = G 1/2

**3 Seal Connector Type (Quench)**

**1** = Standard female connector<sup>①</sup>

**2** = Standard male connector

**3** = 4 in. extended male connector, hex

**4** = 6 in. extended male connector, hex

**5** = 4 in. extended male connector, machined

**6** = 6 in. extended male connector, machined

<sup>①</sup> Installation will require use of pipe nipple (included in kit when female connector selected).

**4 Seal Connection Instrumentation (Quench)**

**1** = None

**2** = Pressure gauge

**3** = Pressure transmitter

**5 Seal Connection Orifice (Quench)**

**A** = No orifice

**B** = Tube fitting union

**C** = Integral to flange adapter<sup>①</sup>

**D** = Orifice plate<sup>①</sup>

<sup>①</sup> Must specify flanged reservoir connections.

**6 Reservoir Capacity**

**12** = 12 liters (3 gallons)

**20** = 20 liters (5 gallons)

**30** = 30 liters (8 gallons)

**38** = 38 liters (10 gallons)

**7 Reservoir Code**

**N** = None

**P** = Pressure Equipment Directive

**U** = ASME

**8 Reservoir Material**

**S** = Carbon steel (painted)

**4** = 304 stainless steel

**6** = 316 stainless steel

**9 Reservoir Connection**

**1** = Flanged, inlet on left

**2** = Flanged, inlet on right

**3** = Tube fittings, fill on left

**4** = Tube fittings, fill on right

**10 Reservoir Level**

**A** = None

**B** = Sight gauge



## API Plan 62 Quench from External Source

API Plan 62 delivers an external quench fluid to the atmospheric side of the seal. A typical application in a refinery is the prevention of coking on seal faces in hot hydrocarbon service by employing a steam quench. Nitrogen or clean water may also be used to quench or cool and clean the atmospheric side of the seal.

Plan 62 prevents the formation of, or clears, solids from the atmospheric side of the seal faces.

Plan 62 is available as a kit of components ready for field assembly.

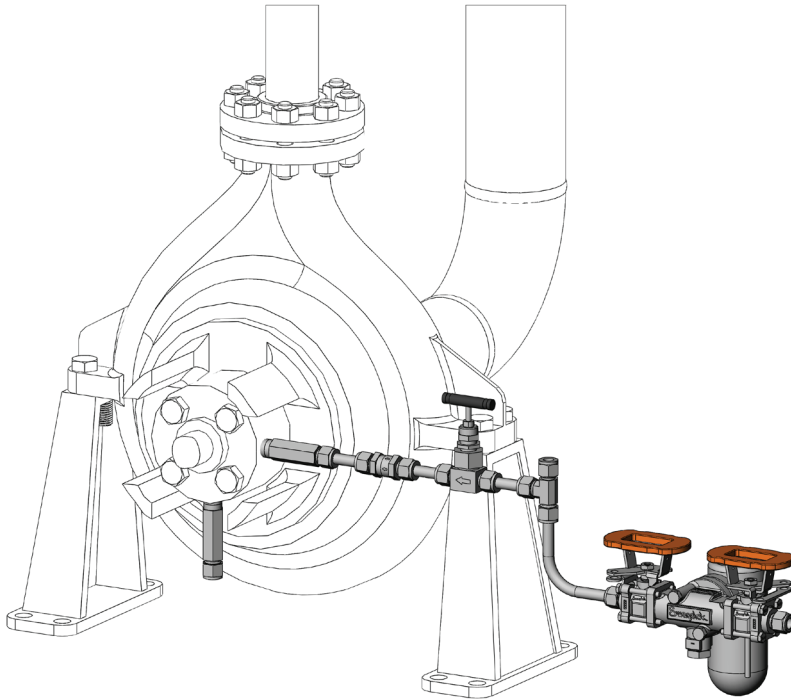

**Fig. 58 API Plan 62**

Kit contents shown solid and include some optional components.

*Kit contents may include:*

- Swagelok tube fittings
- V series 2-valve manifold
- CH series check valves
- N series needle valves
- PGI series gauges
- Swagelok pipe fittings
- Bimetal thermometer
- TTW series thermowell tee
- TVA series steam trap test station
- Steam trap
- Pipe nipple

See page 83 for additional information on individual components.

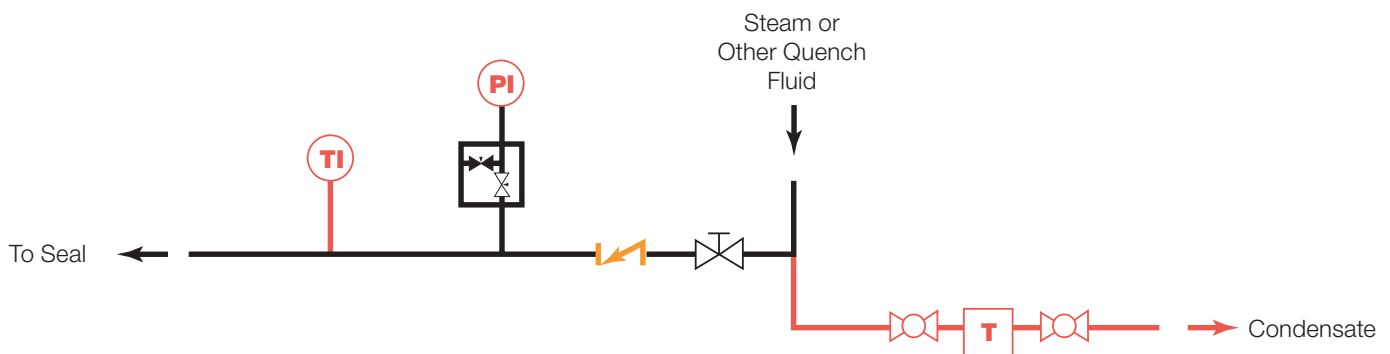

**Fig. 59 Plan 62 P&ID**

Optional components shown in red.

Contact your authorized Swagelok sales and service center for information on optional components.

**API Plan 62 continued****Ordering Information**

Build an ordering number by combining the designators in the sequence shown below.

**Plan 62 Kit**

1    2    3    4    5    6    7  
 SPK62 - C - C 4 2 - C 4 - S

**1 Primary Tubing Size**

C = 1/2 in.

K = 12 mm

**2 Seal Connection (Quench Inlet)**

B = 3/8 in. female NPT

C = 1/2 in. female NPT

H = G 3/8

J = G 1/2

**3 Seal Connector Type (Quench Inlet)**

1 = Standard female connector<sup>①</sup>

2 = Standard male connector

3 = 4 in. extended male connector, hex

4 = 6 in. extended male connector, hex

5 = 4 in. extended male connector, machined

6 = 6 in. extended male connector, machined

<sup>①</sup> Installation will require use of pipe nipple (included in kit when female connector selected).

**4 Seal Connection Instrumentation (Quench Inlet)**

1 = None

2 = Pressure gauge

3 = Pressure transmitter

4 = Thermometer

5 = Pressure gauge and thermometer

6 = Pressure transmitter and thermometer

**5 Seal Connection (Drain)**

B = 3/8 in. female NPT

C = 1/2 in. female NPT

D = 3/4 in. female NPT

H = G 3/8

J = G 1/2

K = G 3/4

**6 Seal Connector Type (Drain)**

1 = Standard female connector<sup>①</sup>

2 = Standard male connector

3 = 4 in. extended male connector, hex

4 = 6 in. extended male connector, hex

5 = 4 in. extended male connector, machined

6 = 6 in. extended male connector, machined

<sup>①</sup> Installation will require use of pipe nipple (included in kit when female connector selected).

**7 Quench Fluid**

S = Steam

None = other

## API Plan 65A Leakage Collection with Reservoir

API Plan 65A monitors leakage in a single seal arrangement. Connected to the drain port on the gland, a reservoir collects normal leakage and is constantly open to drain. In the event of a seal failure, an orifice fitting on the outlet of the system allows a level transmitter to trigger an alarm due to the excessive leakage.

Plan 65A collects leakage of condensing process fluid.

Plan 65A is available as a kit of components ready for field assembly.

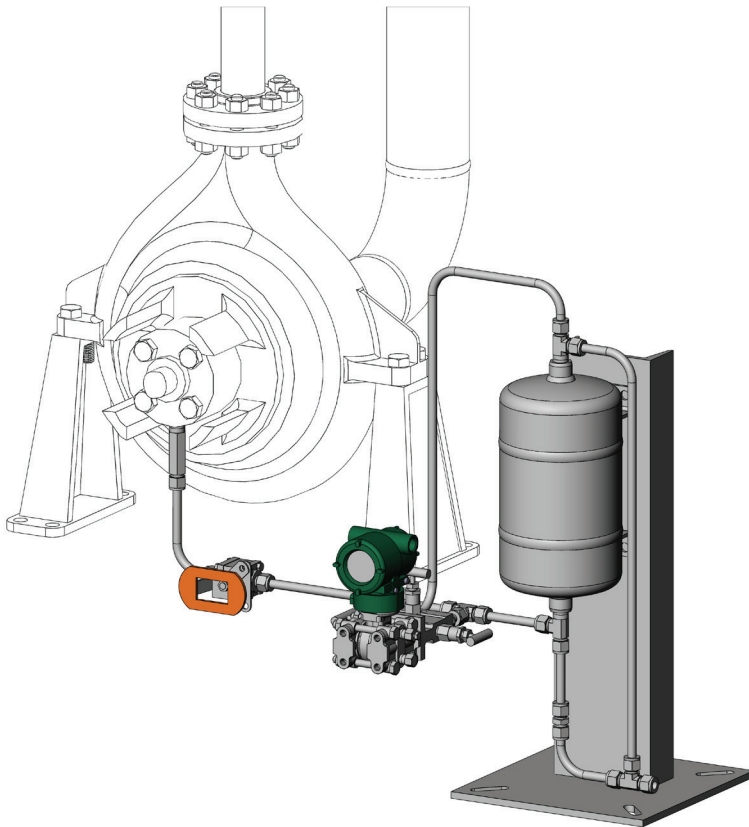

**Fig. 60 API Plan 65A**

Kit contents shown solid and include some optional components.

*Kit contents may include:*

- Swagelok tube fittings
- 63 series ball valve
- V series 2-valve manifold
- Pipe nipple
- Collection reservoir
- Reservoir stand
- Level transmitter

See page 83 for additional information on individual components.

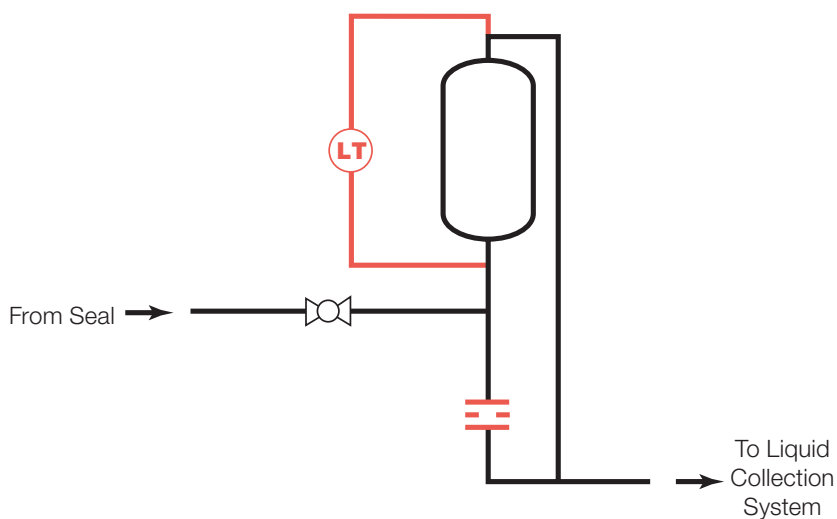

**Fig. 61 Plan 65A P&ID**

Optional components shown in red.

Contact your authorized Swagelok sales and service center for information on optional components.

**API Plan 65A continued****Ordering Information**

Build an ordering number by combining the designators in the sequence shown below.

**Plan 65A Kit**

SPK65A - **1** **2** **3** **4** **5** **6** **7** **8**  
**C** - **C** **4** - **03** **N** **4** **F** **B**

**1 Primary Tubing Size**

**C** = 1/2 in.

**K** = 12 mm

**2 Seal Connection (Drain)**

**B** = 3/8 in. female NPT

**C** = 1/2 in. female NPT

**D** = 3/4 in. female NPT

**H** = G 3/8

**J** = G 1/2

**K** = G 3/4

**3 Seal Connector Type (Drain)**

**1** = Standard female connector<sup>①</sup>

**2** = Standard male connector

**3** = 4 in. extended male connector, hex

**4** = 6 in. extended male connector, hex

**5** = 4 in. extended male connector, machined

**6** = 6 in. extended male connector, machined

<sup>①</sup> Installation will require use of pipe nipple (included in kit when female connector selected).

**4 Reservoir Capacity**

**03** = 3 liters (0.75 gallons)

**5 Reservoir Code**

**N** = None

**P** = Pressure Equipment Directive

**U** = ASME

**6 Reservoir Material**

**S** = Carbon steel (painted)

**4** = 304 stainless steel

**6** = 316 stainless steel

**7 Reservoir Level**

**A** = None

**F** = Transmitter

**8 Reservoir Orifice**

**A** = No orifice

**B** = Tube fitting union

## API Plan 65B Leakage Collection with Reservoir

API Plan 65B monitors leakage in a single seal arrangement. Connected to the drain port on the gland, a reservoir is allowed to collect normal leakage. A level transmitter on the reservoir triggers an alarm in the event of excessive leakage. A valve on the outlet side of the reservoir is typically left closed and is only opened periodically to drain the reservoir.

Plan 65A collects leakage of condensing process fluid.

Plan 65B is available as a kit of components ready for field assembly.

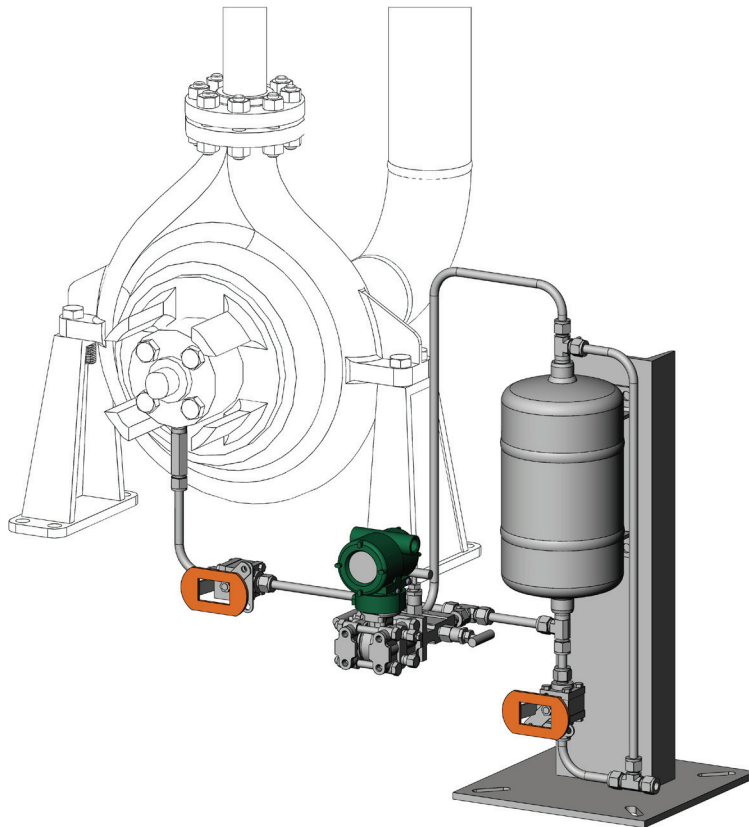

**Fig. 62 API Plan 65B**

Kit shown with some optional components.

*Kit contents may include:*

- Swagelok tube fittings
- 63 series ball valves
- V series 2-valve manifold
- Pipe nipple
- Collection reservoir
- Reservoir stand
- Level transmitter

See page 83 for additional information on individual components.

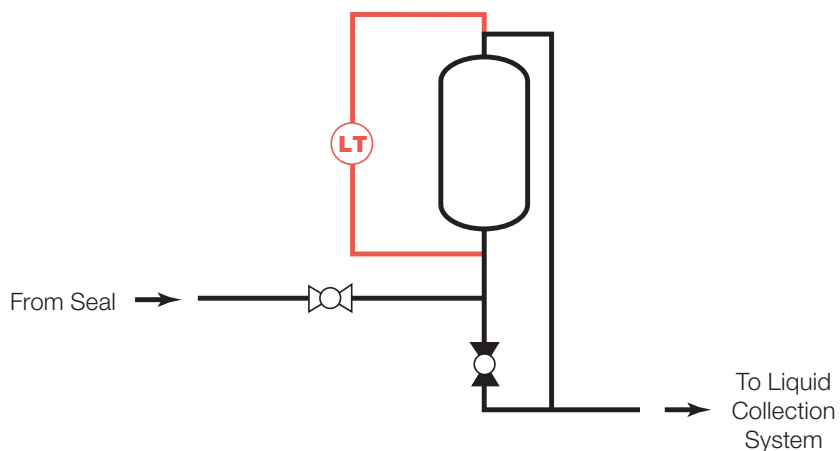

**Fig. 63 Plan 65B P&ID**

Optional components shown in red.

Contact your authorized Swagelok sales and service center for information on optional components.

**API Plan 65B continued****Ordering Information**

Build an ordering number by combining the designators in the sequence shown below.

**Plan 65B Kit**

SPK65B - **1** - **2** **3** - **4** **5** **6** **7**  
**C** - **C** **4** - **03** **N** **4** **F**

**1 Primary Tubing Size**

**C** = 1/2 in.

**K** = 12 mm

**2 Seal Connection (Drain)**

**B** = 3/8 in. female NPT

**C** = 1/2 in. female NPT

**D** = 3/4 in. female NPT

**H** = G 3/8

**J** = G 1/2

**K** = G 3/4

**3 Seal Connector Type (Drain)**

**1** = Standard female connector<sup>①</sup>

**2** = Standard male connector

**3** = 4 in. extended male connector, hex

**4** = 6 in. extended male connector, hex

**5** = 4 in. extended male connector, machined

**6** = 6 in. extended male connector, machined

<sup>①</sup> Installation will require use of pipe nipple (included in kit when female connector selected).

**4 Reservoir Capacity**

**03** = 3 liters (0.75 gallons)

**5 Reservoir Code**

**N** = None

**P** = Pressure Equipment Directive

**U** = ASME

**6 Reservoir Material**

**S** = Carbon steel (painted)

**4** = 304 stainless steel

**6** = 316 stainless steel

**7 Reservoir Level**

**A** = None

**F** = Transmitter

## Glossary

### Swagelok Component Literature Reference

Component	Model/Series	Material Grade/ASTM Specification
Stainless steel tube fittings	—	316 SS/A276 or A182 See Swagelok <i>Gaugeable Tube Fittings and Adapter Fittings</i> , MS-01-140
Stainless steel pipe fittings	—	316 SS/A276 and A812 See Swagelok <i>Pipe Fittings</i> , MS-01-147
Flange adapters	—	316 SS/A182 See Swagelok <i>Flange Adapters</i> , MS-02-200
Ball valve	43G series	See Swagelok <i>One-Piece Instrumentation Ball Valves—40G Series and 40 Series</i> , MS-02-331
	63 series	See Swagelok <i>Ball Valves, General Purpose and Special Applications 60 Series</i> , MS-01-146
Check valve	CH series	See Swagelok <i>Check Valves, C, CA, CH, and CPA Series</i> , MS-01-176
Needle valve	1 series	See Swagelok <i>Integral Bonnet Needle Valves, 0, 1, 18, 20, and 26 Series</i> , MS-01-164
	N series	See Swagelok <i>Severe-Service Union-Bonnet Needle Valves</i> , MS-01-168
Manifolds	V2 series	See Swagelok <i>Instrument Manifold Systems</i> , MS-02-445
Relief valve, proportional	R series	See Swagelok <i>Proportional Relief Valves</i> , MS-01-141
Stainless steel quick connects	QTM series	316 SS See Swagelok <i>Quick Connects QC, QF, QM, and QTM Series</i> , MS-01-138
Thermowell tee	TTW series	See Swagelok <i>Temperature Measurement Devices, Bimetal Thermometers and Thermowells</i> , MS-02-353
Filter	FC series	See Swagelok <i>Gas Filters, FC Series</i> , MS-02-82
Regulator	KPR series and KHF series	See Swagelok <i>Pressure Regulators, K Series</i> , MS-02-230
Pressure indicator	PGI series pressure gauge	See Swagelok <i>Pressure Gauges, Industrial and Process—PGI Series</i> , MS-02-170
Flowmeter	G2, M1, M2, and M4 models	See Swagelok <i>Variable Area Flowmeters, G Series and M Series</i> , MS-02-346
Bimetal thermometer	—	See Swagelok <i>Temperature Measurement Devices, Bimetal Thermometers and Thermowells</i> , MS-02-353
TVA steam trap test station	TVA series	See Swagelok <i>Steam Trap Test Station with Universal Mount, TVA Series</i> , MS-02-221
Stainless steel panel, brackets, screws	Swagelok	300 series stainless steel

**Safe Product Selection**

**When selecting a product, the total system design must be considered to ensure safe, trouble-free performance. Function, material compatibility, adequate ratings, proper installation, operation, and maintenance are the responsibilities of the system designer and user.**

**Caution: Do not mix or interchange Swagelok product components with those of other manufacturers.**

## Warranty Information

Swagelok products are backed by The Swagelok Limited Lifetime Warranty. For a copy, visit [swagelok.com](http://swagelok.com) or contact your authorized Swagelok representative.