

CASE No.

THIS ASSEMBLY DESIGN, FUNCTION, AND APPLICATION ARE THE EXPRESS SOLE RESPONSIBILITY OF THE PURCHASER.

CONCEPT DRAWING

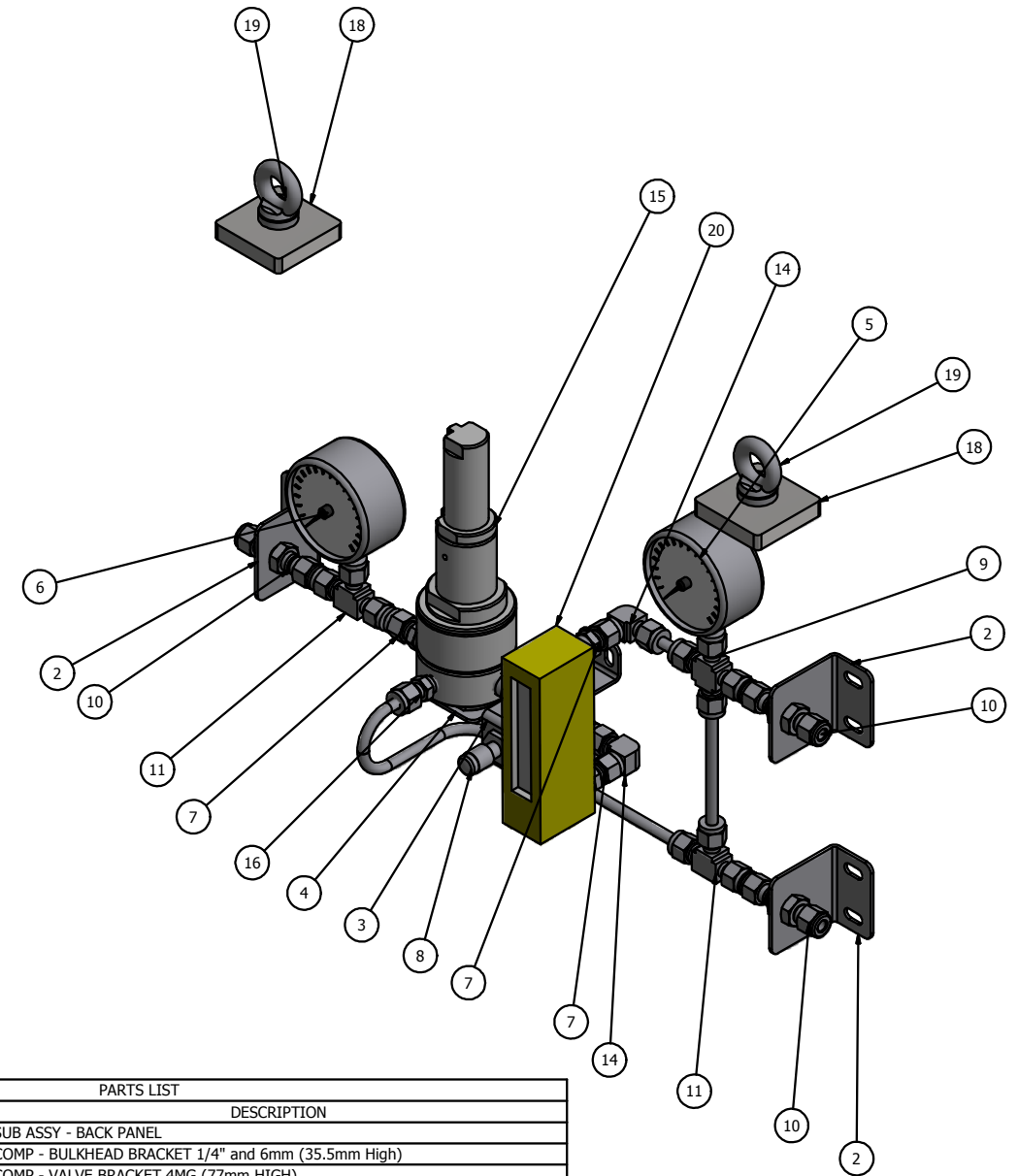
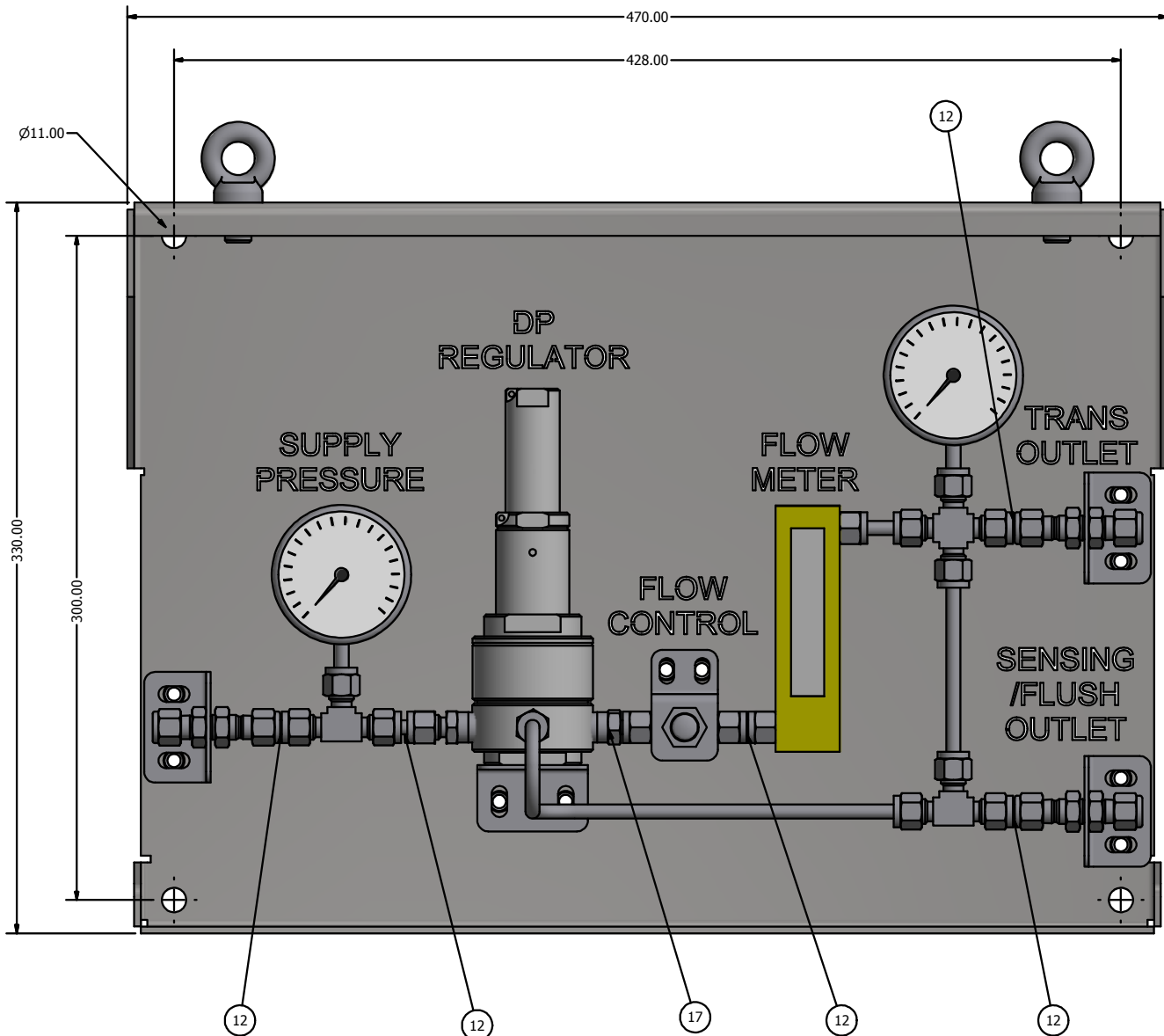

PARTS LIST			
ITEM	QTY	PART NUMBER	DESCRIPTION
1	1	SOPFAB125853-02-DEMO	SUB ASSY - BACK PANEL
2	3	SOPFAB125853-06	COMP - BULKHEAD BRACKET 1/4" and 6mm (35.5mm High)
3	1	SOPFAB125853-10	COMP - VALVE BRACKET 4MG (77mm HIGH)
4	1	SOPFAB125853-11	COMP - REGULATOR SUPPORT BRACKET
5	1	PGI-63B-BG1-LAQX	Safety Gauge St St 63mm Dial, 1 Bar G, 1/4" tube adaptor
6	1	PGI-63B-BG10-LAQX	Safety Gauge St St 63mm Dial, 10 Bar G, 1/4" tube adaptor
7	3	SS-400-1-4	SS Swagelok Tube Fitting, Male Connector, 1/4 in. Tube OD x 1/4 in. Male NPT
8	1	SS-4MG	Medium-Flow Metering Valve 1/4" OD
9	1	SS-400-4	Union Cross 1/4" OD
10	3	SS-400-61	Bulkhead Union 1/4" OD
11	2	SS-400-3	Union Tee 1/4" OD
12	5	SS-401-PC	Port Connector 1/4" OD
13	3	SS-T4-S-035-6ME	Tubing 1/4" x 0.035 Wall
14	2	SS-400-2R-4	SS Swagelok Tube Fitting, Swagelok Tube Adapter 90° Elbow, 1/4 in. Tube OD x 1/4 in. Swagelok Tube Adapter
15	1	RDN2-02-VVK-DP2-A-50104	Regulator with adjustable differential pressure, RDN2 1/4" NPTF, Inlet Outlet
16	1	SS-400-1-2	SS Swagelok Tube Fitting, Male Connector, 1/4 in. Tube OD x 1/8 in. Male NPT
17	1	SS-4-TA-1-4	Swagelok Tube Fitting, Male Tube Adapter, 1/4 in. Tube OD x 1/4 in. Male NPT
18	2	SOPFAB117250-09	COMP - LIFTING PLATE
19	2	Eye Bolt M12 400Kg	
20	1	VAF-G1-07L-1-0-Y	Variable Area Flowmeter, Model G1, 1/4" NPTF, 0.42-4.2NL/min, No Needle Valve

REVISION HISTORY			
REV	DATE	DESCRIPTION	APPROVED
V01		INITIAL RELEASE	M VARIAVA
PROJECT No		BOM No	
THIS ASSEMBLY DESIGN, FUNCTION, AND APPLICATION ARE THE EXPRESS SOLE RESPONSIBILITY OF THE PURCHASER. PURCHASER IS SOLELY RESPONSIBLE FOR THE FIT AND FUNCTION OF ANY COMPONENTS. PURCHASER AGREES TO HOLD HARMLESS AND INDEMNIFY SWAGelok FROM AND AGAINST ANY CLAIMS ARISING FROM OR RELATING TO ANY OF THE FOREGOING.			
CUSTOMER			
TITLE GEN ASSY - DIFFERENTIAL PRESSURE REDUCTION PANEL			
DWG NO		REV V01	
SHEET		OF 2	

CUSTOMER APPROVAL  
APPROVED? YES NO  
BY/DATE

Swagelok

DRAWING NOT TO SCALE.  
DIMENSIONS ARE MILLIMETERS.  
DRAWING IS SUBJECT TO CHANGE WITHOUT NOTICE.  
ANGULAR ± 0.5°

GENERAL TOLERANCES UNLESS STATED			
OVER	UP TO	ASSEMBLY	ORB/FAB
0	100	± 1.0	± 0.125
101	500	± 2.0	± 0.25
501	1000	± 3.0	± 0.5
1001	----	± 4.0	± 0.75

DRAWN  
M.JL  
CHECKED  
M.V.