

Gas Distribution Systems

Application Guide

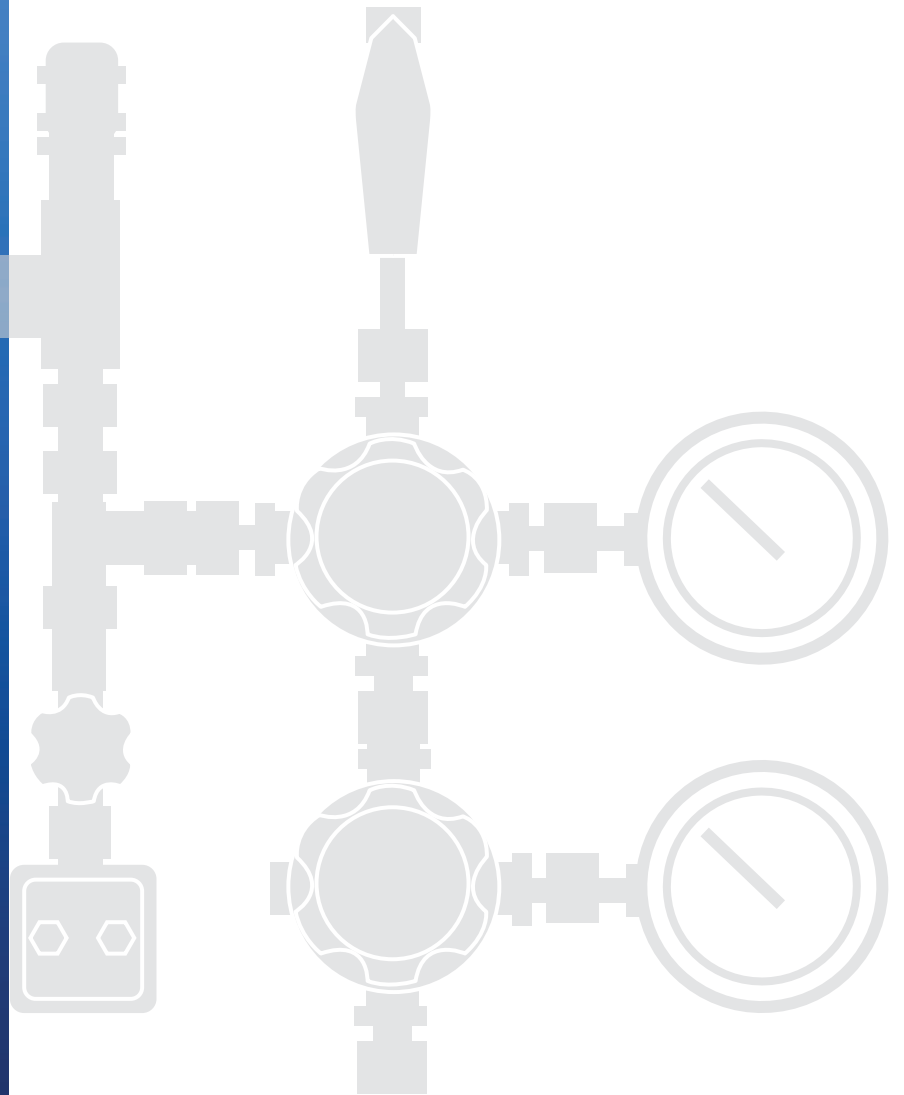

Configurable.
Local.
Reliable.

Swagelok®

Contents

What Is a Gas Distribution System?	3
How Pressure Regulator Selection Affects Gas Distribution Performance	5
Symbol Definitions	9
Swagelok Gas Distribution Systems	9
Source Inlet Connection (SSI)	
<i>Description</i>	10
<i>P&ID</i>	11
<i>Ordering Information</i>	12
<i>Dimensions</i>	13
Primary Gas Control System (SGP)	
<i>Description</i>	14
<i>P&ID</i>	16
<i>Ordering Information</i>	17
<i>Dimensions</i>	18
Point-of-Use System (SPU)	
<i>Description</i>	19
<i>P&ID</i>	20
<i>Ordering Information</i>	21
<i>Dimensions</i>	22
Automatic Changeover System (SCO)	
<i>Description</i>	23
<i>P&ID</i>	24
<i>Ordering Information</i>	25
<i>Dimensions</i>	26

What Is a Gas Distribution System?

Gas distribution is a critical function for many industrial, research, and production facilities. Safely, reliably, and effectively delivering gases to where they are needed provide the foundation for a strong operation. Gas distribution systems work to deliver gases from a high-pressure source to the facility at the pressure and flow rate required by each application. Most often built around one or a series of pressure regulation steps, gas distribution systems may have four typical subsystems: Source Inlet Connection, Primary Gas Pressure Control, Point-of-Use, and Automatic Changeover.

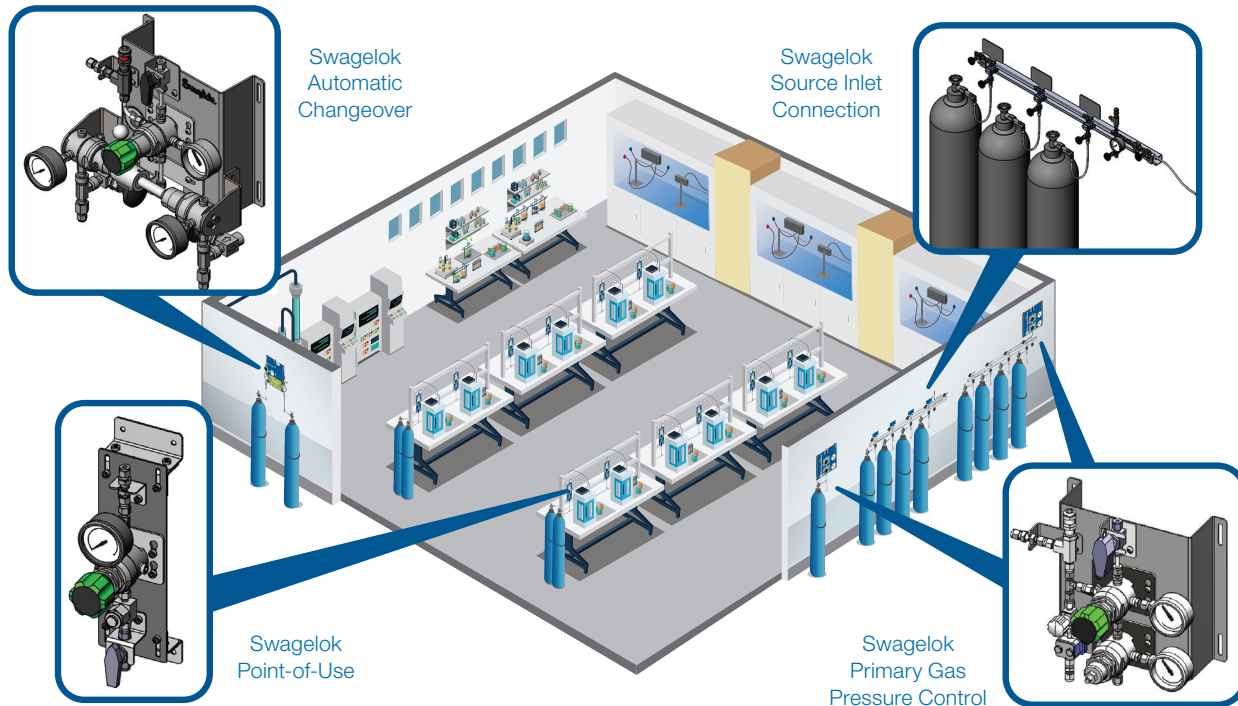

Fig. 1 Example Lab

Source Inlet Connection

The source inlet connection portion of a gas distribution system works to establish a connection between the high-pressure gas source (one or multiple gas cylinders or bottles) and the rest of the gas distribution system. The source inlet should be built with the appropriate cylinder connections, hoses, tubing, and filters, as well as vent, purge, and relief functions to ensure that the gas can be safely fed into the Primary Gas Pressure Control or Automatic Changeover systems. For a single gas cylinder, the source assembly may be as simple as a hose with a cylinder connector. However, where multiple bottles are needed for systems with high gas demands, the source assembly could be a manifold of several hoses and valves leading to a single outlet connection going to the Primary Gas Pressure Control or Automatic Changeover system.

Point-of-Use

Found close to where gas is needed, point-of-use systems are often the least complex of the four main gas distribution subsystems, but provide the critical last stage of pressure control before gas is used. Typically consisting of a pressure regulator, gauge and isolation valve, point-of-use systems give operators and technicians a convenient and accurate method of adjusting pressure to meet their test bench or equipment needs.

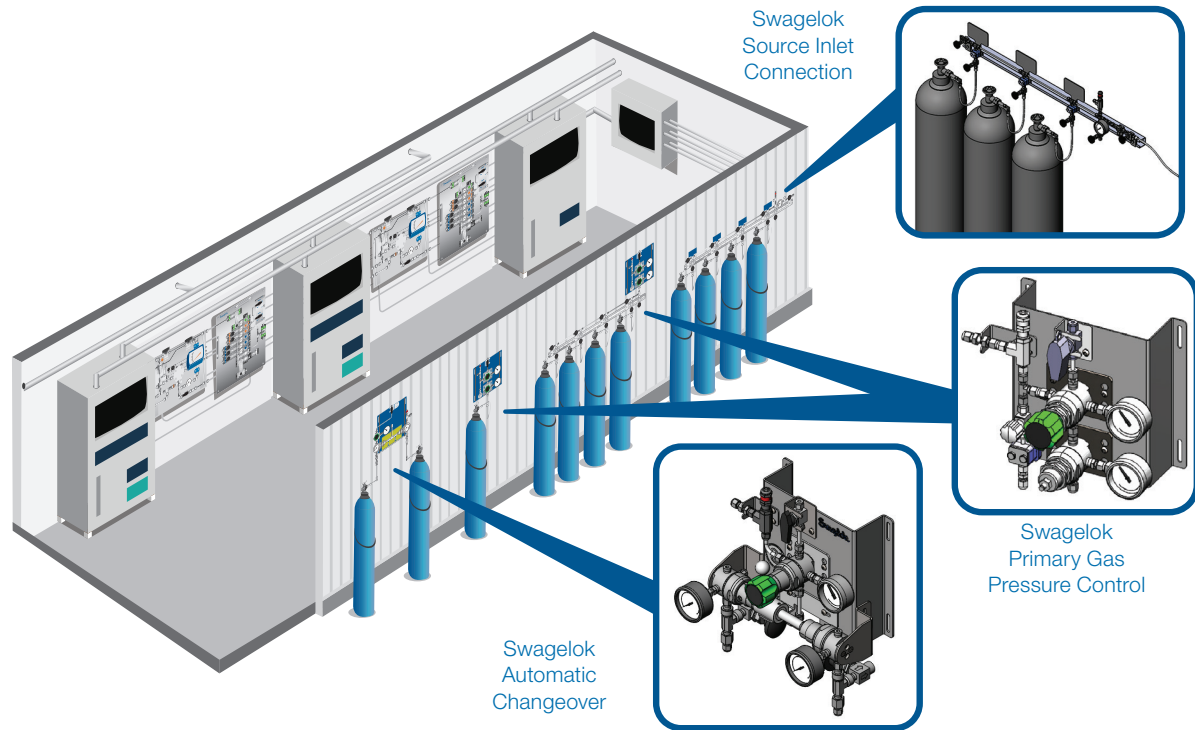

Fig. 2 Example Analytical Instrumentation Shelter

Primary Gas Pressure Control

Typically close to the source gas, the primary gas pressure control system completes the first pressure reduction of the source gas. Often, this gas is then routed into the facility, laboratory, analyzer shelter, or equipment where the gas is being used. Primary Gas Pressure Control systems must ensure that the gas is delivered at the needed pressure within the system-required flow rates. Pressure reduction is accomplished in either one stage with a single pressure regulator or two stages through a dual pressure regulator arrangement.

Automatic Changeover

A special version of a Primary Gas Pressure Control system, the automatic changeover, or continuous gas supply, system works not only to provide the first pressure control point, but also an uninterrupted supply of gas. Accomplished through staggered set points of two pressure regulators, an Automatic Changeover system will seamlessly switch from one gas source to another. This ensures the system can continue operating as the primary gas source is changed from one bottle to another.

How Pressure Regulator Selection Affects Gas Distribution Performance

Properly sized and selected pressure regulators are a critical component of a properly functioning gas distribution system. There are a few aspects of performance that are most important when choosing a pressure regulator for one of these systems: droop, lock-up or seat-load drop, choked flow, and supply-pressure effect.

Droop, Seat-Load Drop, Choked Flow, and Supply-Pressure Effect

It is best to operate a pressure regulator along the flattest—or most horizontal—part of a flow curve. Indeed, an ideal flow curve would be a flat line. However, no pressure regulator can produce a perfectly flat line over its full range of pressures because its internal components have limitations.

Typically, a flow curve consists of three parts (Fig. 3):

- The ideal operating range, a relatively flat part in the middle
- A steep drop on the far left, which shows seat-load drop or lockup
- A steep drop on the far right, which shows the choked-flow area

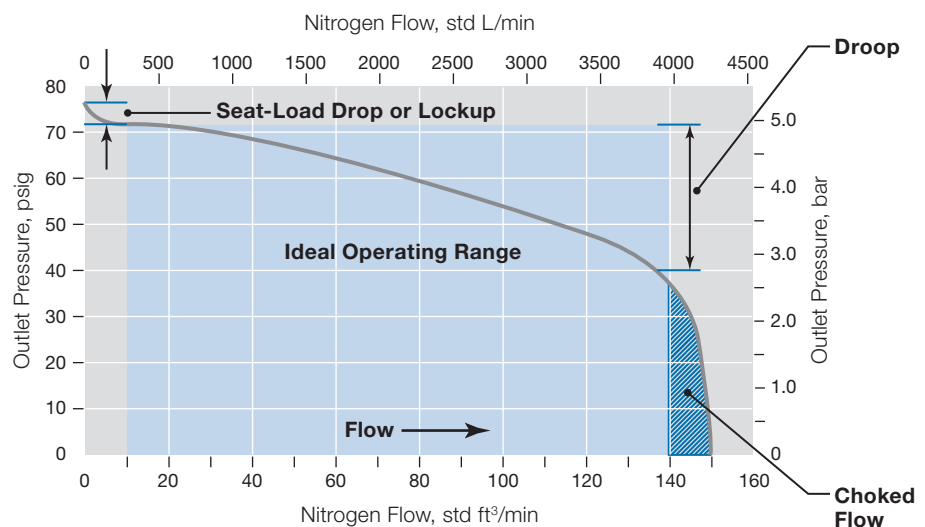

Fig. 3. This typical flow curve for a pressure-reducing regulator illustrates several phenomena, including the ideal operating range, droop, choked flow, and seat-load drop or lockup.

Droop

The flat part in the middle is not perfectly flat. It slopes downward, which is called droop. As flow increases, outlet pressure will drop some, or a lot, depending on the pressure regulator design and system parameters. While droop is relatively modest along the flat part of the curve, it is quite steep at the far ends of the curve.

Supplying a pressure regulator with pressure substantially lower than the outlet pressure rating results in a flow curve with more droop than flow curves for pressure regulators where the outlet pressure rating closely matches actual system pressure. Similarly, selecting a pressure regulator that closely matches inlet pressure requirements provides the best handle resolution (smaller amount of pressure change per turn of the handle) and control, enabling a broader ideal operating range.

Seat-Load Drop or Lockup

Seat-load drop occurs on the far left of the pressure regulator curve (Fig. 3), where there is initially a steep drop in pressure. If reading the curve from left to right, imagine that the system is in a no-flow state. The pressure regulator is set to a certain pressure, but there is no flow. Then, imagine that an operator slowly opens a downstream valve to initiate flow. Immediately, there is a sharp drop in pressure because it is difficult for a pressure regulator to maintain pressure at this location. A pressure regulator operating along this steep drop in the curve may emit chattering or pulsating sounds as it fluctuates between flow and no-flow conditions.

Now read the curve from right to left. Imagine that the system is operating along the flat part of the curve. Then, imagine that an operator slowly closes a downstream valve, reducing flow to near zero. As the no-flow state nears, the pressure regulator has difficulty maintaining the set pressure. Again, the pressure regulator may emit a chattering sound. Eventually, the pressure regulator snaps shut, stopping flow. This is called lockup.

The terms seat-load drop and lockup are essentially interchangeable. Sometimes, lockup is used to describe both conditions. It is not advisable to operate a pressure regulator under these conditions. Some pressure regulator flow data will not reflect lockup, especially for higher-flow models. Typically, lockup pressures will be less than 5% of the total control range for a given model.

Choked Flow

Choked flow occurs on the far right of a curve. See the choked-flow area in Fig. 3, where pressure begins to droop sharply at 140 std ft³/min (3960 std L/min). At this point, the flow demand has exceeded the pressure-controlling capabilities of the pressure regulator. Here, the pressure regulator is wide open and is no longer regulating pressure. Essentially, it has changed from a pressure-controlling device to an open orifice. Increasing downstream flow to this point or beyond renders the pressure regulator ineffective. It is not advisable to operate a pressure regulator in the choked-flow area due to the sharp pressure drop and resulting lack of pressure control.

Note that flow coefficient (C_v) is measured at the pressure regulator's fully open position, and that is why it cannot describe the overall performance of the pressure regulator. In fact, selecting a pressure regulator based solely on its C_v can result in unsatisfactory performance. If the system flow is within range of the pressure regulator's C_v , one may believe that the pressure regulator is the right "size." But that is not necessarily true. The C_v represents the pressure regulator's maximum flow capacity. At maximum flow, a pressure regulator can no longer control pressure.

Supply-Pressure Effect

Supply-pressure effect (SPE), or dependency, is a ratio describing the change in outlet pressure per 100 psi (6.8 bar) change in inlet pressure. In other words, for every 100 psi (6.8 bar) drop in inlet pressure, the outlet pressure will increase by X psi. X is the SPE. For standard pressure-reducing pressure regulators, the outlet pressure increases as supply pressure decreases. The opposite is true as supply pressure increases. This is typically seen with gas cylinder applications. This effect can also be realized on system startup or shutdown.

While the above areas of pressure regulator performance are important to Gas Distribution applications, to learn about other aspects of pressure regulator function, please see the *Pressure Regulators Flow Curves Technical Bulletin*, MS-06-114.

The following are key considerations when choosing your gas distribution system:

Safety

Gas distribution systems may transport gases that can be harmful to operators, equipment, and the environment if leaking. Additionally, the primary function of a gas distribution system is to reduce high-source pressure gases to lower, usable pressures prior to their point of use. The design of and components used within a gas distribution system must be carefully selected to ensure trouble-free operation.

When considering the components used within gas distribution systems, it is important to ensure both the pressure and temperature ratings as well as their method of operation matches system requirements. For example, while a ¼-turn ball valve and multiturn needle valve may carry the same ratings, the operation of each valve is best suited for different purposes and applications. While ball valves are a good fit for most systems, using a fast-acting, ¼-turn valve within an oxygen system can lead to large pressure spikes and the potential for hazardous conditions. (Refer to *Oxygen System Safety*, MS-06-13, for additional consideration for oxygen systems.) Additionally, pressure control valves like relief valves and pressure regulators must be sized so that they can handle the full range of potential pressures and flows to ensure the system can function well and remain safe for operators.

As an additional step, designers can include a restricted flow orifice within the system, typically close to the gas source, in order to limit the maximum flow rate should a major leak or break in the line occur downstream. These restricted flow orifices are a simple and effective way to increase safety within gas distribution systems.

Reliability/Uptime

When a gas distribution system is down, it may affect other processes, laboratory tests, or equipment such as analyzers. A system going down can create the need for maintenance and the expense of replacement parts. For gas distribution systems, reliability goes beyond just prevention of leaks and worn components. Gases need to be delivered within the pressure and flow range required for each application throughout the life of the system. As process conditions, test requirements, or equipment needs change, the gas distribution system must be able to reliably deliver gas to meet those needs. Properly sizing pressure control and flow isolation components to meet a wide range of parameters is important to ensure that the system can be used effectively without modification as needs change. Conversely, components that are selected to meet too broad a parameter set can underperform within the most important range, impacting the effectiveness of the system. It is important to select components that are not only robust enough to perform reliably but also sized correctly to be most effective within the expected flow and pressure ranges.

Cost Reduction/Avoidance

Gas can be an expensive budget item, so leaks in gas distribution systems or unused gas in supply bottles means wasted money. Also, replacing or maintaining gas distribution systems that leak or do not function properly uses money and resources that could be better used elsewhere.

Most importantly, gas distribution systems must deliver gases to their intended point of use and nowhere else. Even the most common gases can add up to be a significant portion of a facility's costs. This cost becomes even more impactful when considering expensive gases like helium, hydrogen, or special mixtures. Leaking connections are a very common source of fiscal losses within gas distribution systems. Threaded connections, while a popular choice for gas distribution systems, can be prone to leakage. Using compression fittings where possible minimizes the potential for leakage, especially following maintenance operations where connections are broken and remade.

Time/Resources

Across industries, users have less time and fewer resources to build and maintain gas distribution systems on-site. Additionally, as an aging workforce retires, knowledge and expertise to specify the appropriate product (specifically pressure regulators) or design for their applications are being reduced. Often, sites are running on tight project timelines and don't have time or budget to spend on testing systems during installation. However, when systems fail to function properly, time and resources must be committed to troubleshooting and maintenance.

Very often, when a gas distribution system has an issue, fixing the problem becomes a top priority as work downstream is likely impacted. While preventing issues like connection leaks through using compression fittings in place of threaded connections is ideal, sometimes maintenance is required. In order to minimize the impact of planned or unplanned maintenance on gas distribution systems, it is important that the system design allows for quick access and easy replacement of components. By minimizing the time required to access parts for maintenance, technicians can be more productive and get systems up and running quicker, keeping the site running.

Symbol Definitions

The following symbols are used in the piping and instrumentation diagrams (P&IDs) of the systems described in this application guide. Please use this page for reference.

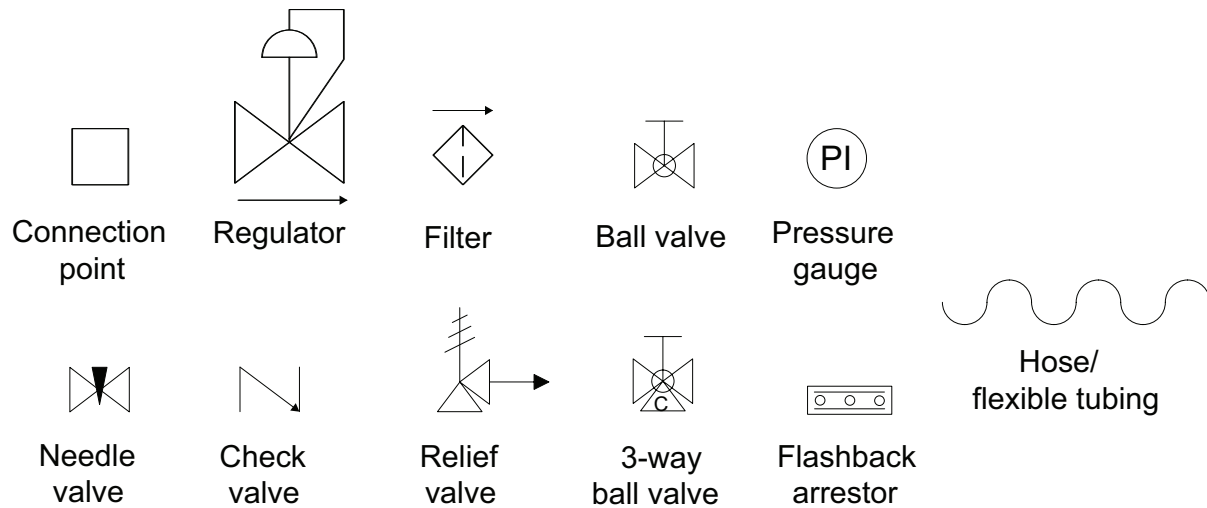

Swagelok Gas Distribution Systems

Swagelok has four standard types of systems available that cover the four typical subsystems:

- SSI - source inlet connection
- SGP - primary gas pressure control
- SCO - automatic changeover
- SPU - point-of-use

All of these systems are highly configurable, and components within the systems can be easily removed or replaced for maintenance due to flexible mounting solutions and the use of Swagelok tube fittings. The designs of Swagelok gas distribution systems make it easy to ensure you're getting the most usage of the gas in your supply bottles. They are fully assembled using high-quality, leak-tight Swagelok components and tested prior to delivery. This ensures reliable, long-lasting performance to help you reduce costs, time, and resources needed for troubleshooting and maintenance, and that they will work reliably to keep your systems running. Read on for detailed information about each one.

Source Inlet Connection (SSI)

For installations where there is heavy gas usage or where extra control is needed prior to the primary gas control system (SGP), a Source Inlet Connection (SSI) may be used. An SSI typically includes isolation, vent, and purge options. Additionally, there will be hoses or hard-tubing pigtails to connect each bottle to the manifold.

The SSI is limited to a pressure rating of 4351 psig (300 bar).

SSI features include:

- Configurable bottle spacing to accommodate a wide range of bottle storage methods
- Bottle identification tags
- Ability to isolate individual gas bottles or entire manifold to maximize safety

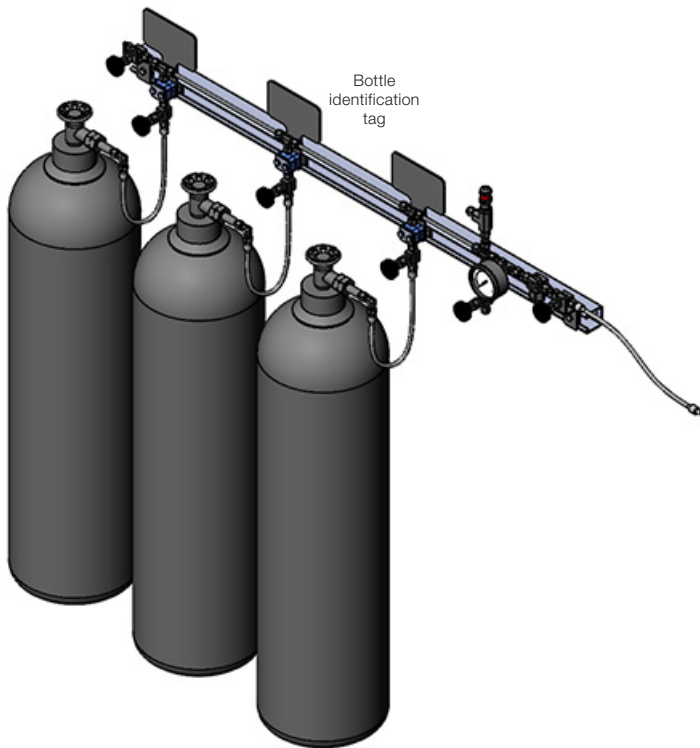

Fig. 4 SSI for Three Bottles



Fig. 5 SSI for One Bottle

System may include:

- 40 series ball valve
- Swagelok tube fittings
- Seamless tubing
- TF series filter
- R series relief valve
- Swagelok hose
- PGI series gauges (63B)
- D series nonrotating-stem needle valve
- Bracket/misc hardware

SSI continued

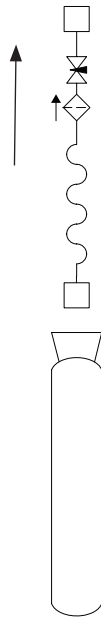

Fig. 6 SSI P&ID for One Bottle

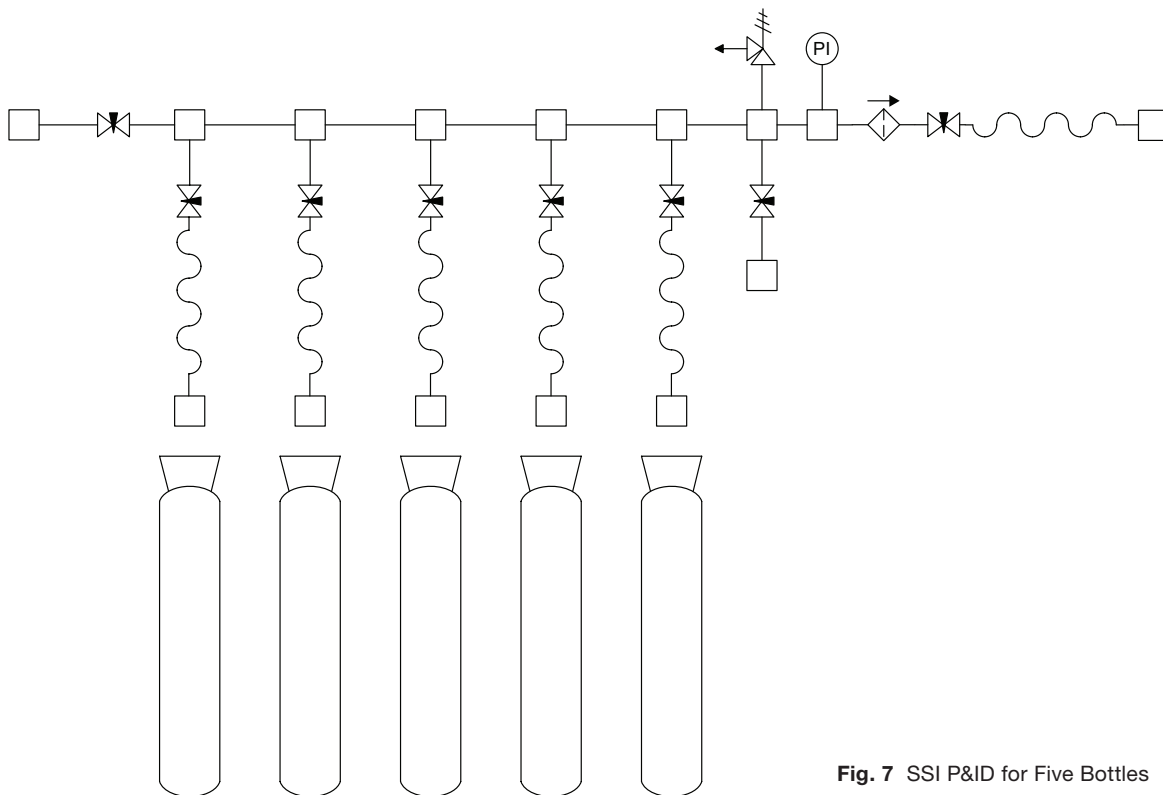

Fig. 7 SSI P&ID for Five Bottles

SSI continued

Ordering Information

Build an ordering number by combining the designators in the sequence shown below.

SSI **1** **2** **3** **4** **5** **6** **7** **8** **9** **10** **11** **12** **13**
N 4 C G 8 1 1 0 1 1 TH S8 E

1 Gas Type

- N = Inert
- H = Hydrogen
- O = Oxygen®

① A gas type of oxygen may limit selections available for other components.

2 Number of Bottles

3 Bottle Connections

See reference table

4 Bottle Connection Size

See reference table

5 Tube OD

- 4 = 1/4 in.
- 8 = 1/2 in.
- A = 6 mm
- B = 12 mm

6 Isolation Valve

- 0 = None
- 1 = On main line
- 2 = On individual bottles
- 3 = On main line and individual bottles

7 Vent Valve

- 0 = None
- 1 = On main vent

8 Purge Valve

- 0 = None
- 1 = On main vent
- 2 = On individual bottles

9 Relief Valve

- 0 = None
- 1 = Yes
- 2 = Country/regional standard

10 Pressure Gauge

- 0 = None
- 1 = Yes

11 Inlet Connection

- 00 = None
- S4 = 1/4 in. Swagelok tube fitting
- S8 = 1/2 in. Swagelok tube fitting
- M6 = 6 mm Swagelok tube fitting
- M2 = 12 mm Swagelok tube fitting
- F4 = 1/4 in. Female NPT
- TH = TH hose
- XT = XT hose
- FM = FM hose
- FX = FX hose
- 8R = Thermoplastic hose
- FP = Pigtail
- MP = Metric pigtail
- FR = Rectoil
- MR = Metric rectoil

12 Outlet Connection

- 00 = None
- S4 = 1/4 in. Swagelok tube fitting
- S8 = 1/2 in. Swagelok tube fitting
- M6 = 6 mm Swagelok tube fitting
- M2 = 12 mm Swagelok tube fitting
- F4 = 1/4 in. Female NPT
- TH = TH hose
- XT = XT hose
- FM = FM hose
- FX = FX hose
- 8R = Thermoplastic hose
- FP = Pigtail
- MP = Metric pigtail
- FR = Rectoil
- MR = Metric rectoil

13 Options

- H = Helium leak test
- E = ASME 3.1 material certification

Note: Multiple options can be added to the end of an ordering number.

	Character	Position 3: Connection Standard					Examples	Position 3 & 4
		CGA	BS341 <=250Bar	BS341 <=300Bar	DIN477-1 <=200Bar	DIN477-5		
Position 4: Connection Type	1		1	31	1		CGA 350	CD
	2	680		32			CGA 660	CJ
	3	695	3				BS10	B0
	4		4				BS31	31
	5					54	DIN10	D0
	6				5	55	DIN9	D9
	7				6	56		
	8				7	57		
	9			38	8	58		
	0		10	30	9	59		
	A				10	50		
	B	320	12		11	60		
	C		13		12			
	D	350	14		13			
	E		15		14			
	F	540	16					
G	580							
H	590							
J	660							

SSI continued**Dimensions**

Dimensions, in inches (millimeters), are for reference only and are subject to change.

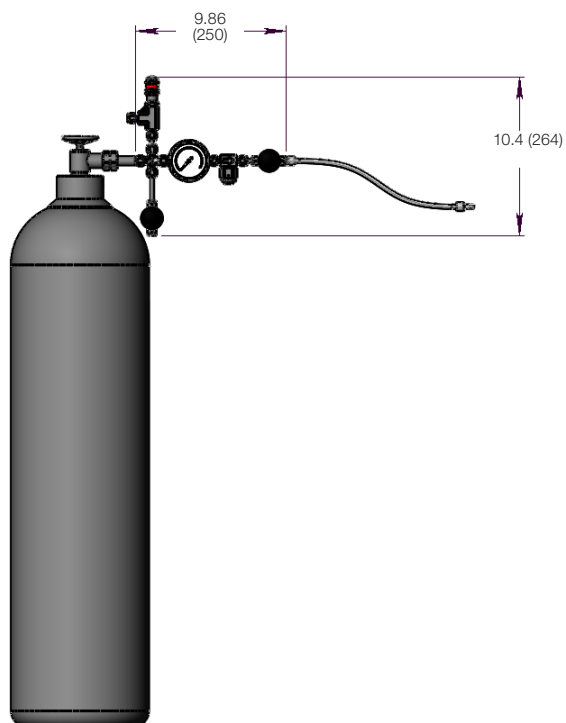
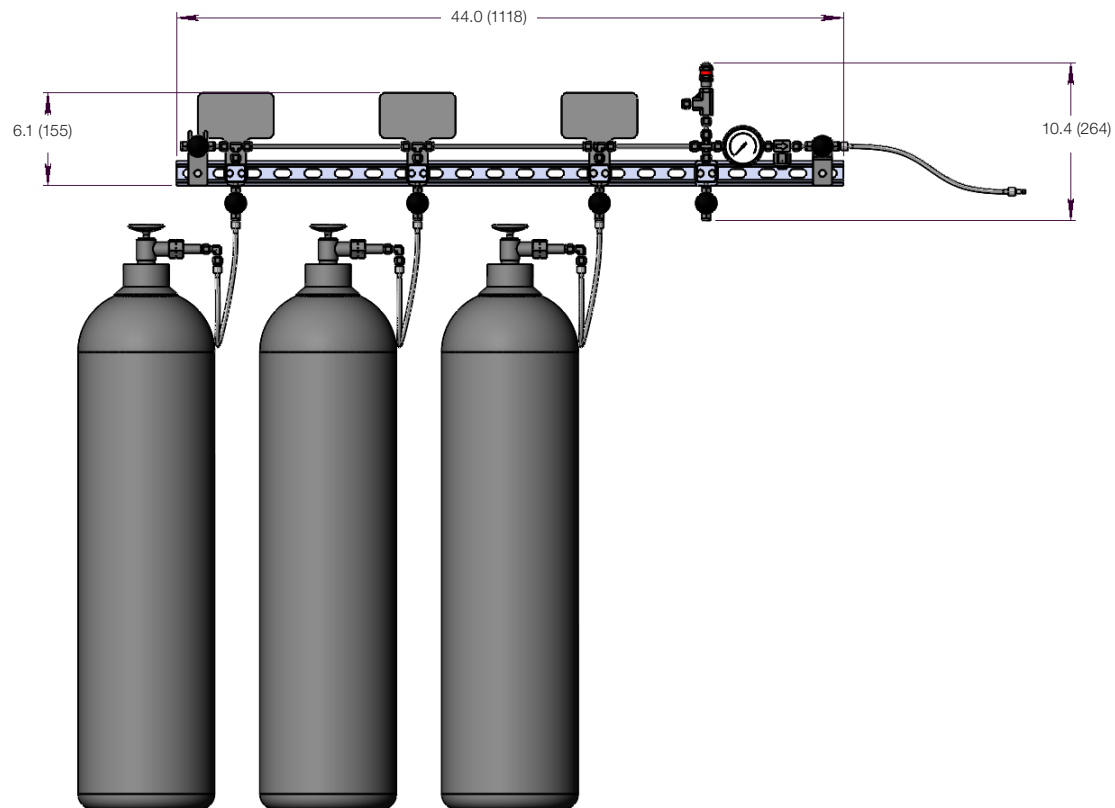

Primary Gas Control System (SGP) – Single- and Dual-Stage

Swagelok's Primary Gas Control System (SGP) is used predominately to reduce gas pressure at or near the source prior to a larger gas distribution network. With many variations possible within a standard footprint, each system can be configured to meet specific needs while being easily integrated into the overall installation.

Being the first point of gas control, these systems can be built with either single- or dual-stage pressure regulation to accurately deliver gas while minimizing the supply-pressure effect and providing ease of use, depending on system needs. Additionally, several vent, purge, and relief options can be incorporated to enhance safety.

SGP features include:

- A standardized backplate sized to match the width of standard gas bottles so that on-site installation is quick and easy without needing to stagger system placement
- Easy serviceability, minimizing downtime if maintenance is needed
- Upstream and downstream pressure indicators
- Long service life, which is further improved when paired with Swagelok's Source Inlet Connection system (SSI)

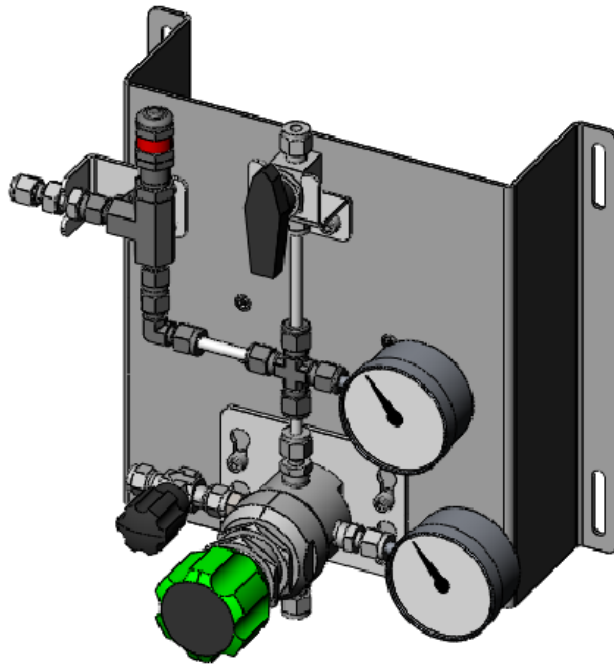

Fig. 8 SGP Single Stage

System may include:

- KPR series pressure regulator
- R3A series relief valve
- 40 series ball valve
- Swagelok tube fittings
- D series nonrotating-stem needle valve
- PGI series gauges (63C)
- Seamless tubing
- Panel
- Bracket/misc hardware

SGP continued

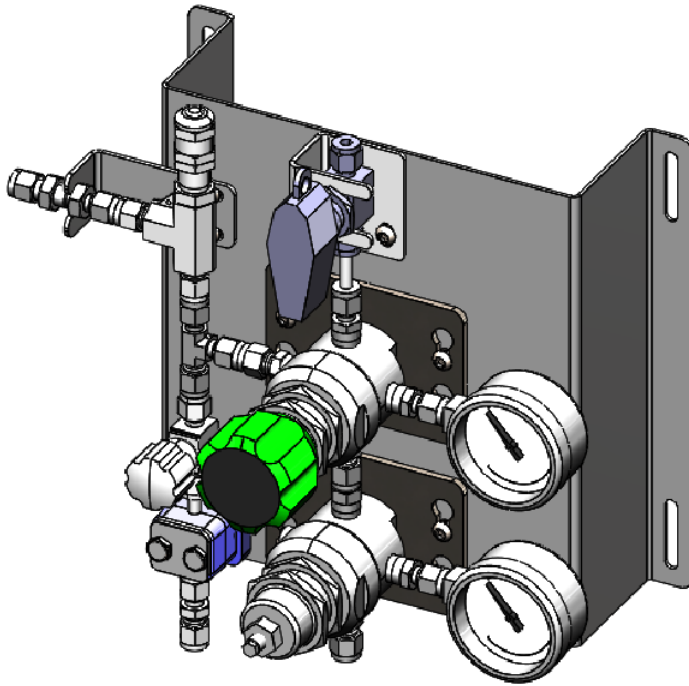

Fig. 9 SGP Dual Stage

System may include:

- KPR series pressure regulator
- R3A series relief valve
- 40 series ball valve
- Swagelok tube fittings
- D series nonrotating-stem needle valve
- PGI series gauges (63C)
- Seamless tubing
- Panel
- Bracket/misc hardware

SGP continued

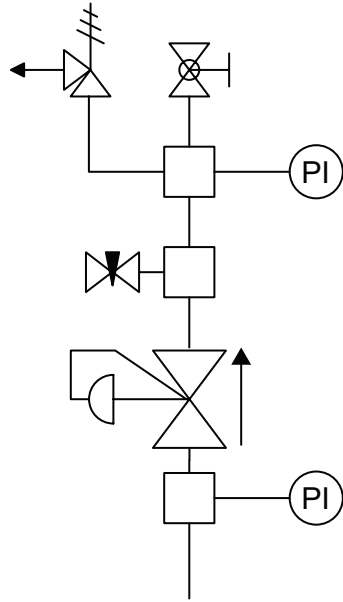

Fig. 10 Single-Stage SGP P&ID

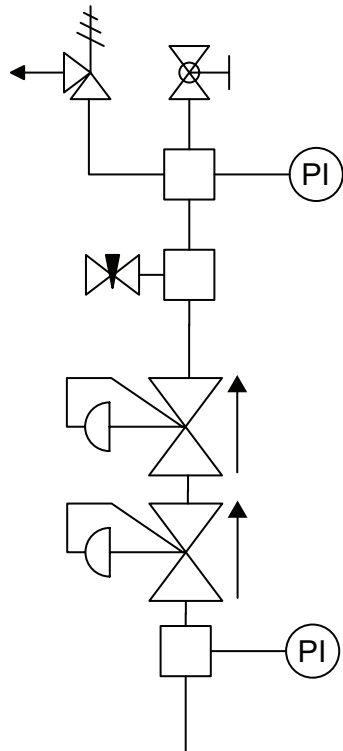

Fig. 11 Dual-Stage SGP P&ID

SGP continued

Ordering Information

Build an ordering number by combining the designators in the sequence shown below.

1 2 3 4 5 6 7 8 9 10 11
 SGP **2 H R G 5 4 1 S4 S4 S4 E**

1 Panel Type

- 1 = Single-stage
- 2 = Dual-stage
- 3 = Dual-stage single body^①

① A Cv of 0.02 and the captured pressure regulator vent option are not available with this panel type.

2 Gas Type

- N = Inert
- H = Hydrogen
- O = Oxygen^①

① A gas type of oxygen may limit selections available for other components.

3 Max Inlet Pressure

- L = 1000 psig (68.9 bar)
- R = 3600 psig (248 bar)
- T = 4351 psig (300 bar)

4 Outlet Control Range

- E = 0 to 50 psig (0 to 3.4 bar)
- F = 0 to 100 psig (0 to 6.8 bar)
- G = 0 to 250 psig (0 to 17.2 bar)
- J = 0 to 500 psig (0 to 34.4 bar)

5 C_v (Flow Coefficient)

- 1 = 0.02
- 2 = 0.06
- 5 = 0.2
- 7 = 0.5

6 Outlet Valve

- 0 = No valve
- 4 = 1/4-turn outlet isolation valve
- L = Lockable 1/4-turn ball valve
- X = 3-way ball valve (vent/isolation)
- T = Lockable 3-way ball valve
- D = Multiturn needle valve

7 Pressure Relief Valve

- 0 = None
- 1 = 4R3A series relief valve
- 2 = Country/regional standard

8 Inlet Connection

- S4 = 1/4 in. Swagelok tube fitting
- S8 = 1/2 in. Swagelok tube fitting
- M6 = 6 mm Swagelok tube fitting
- M2 = 12 mm Swagelok tube fitting
- F4 = 1/4 in. Female NPT
- M1 = 10 mm Swagelok tube fitting

9 Outlet Connection

- S4 = 1/4 in. Swagelok tube fitting
- S6 = 3/8 in. Swagelok tube fitting
- S8 = 1/2 in. Swagelok tube fitting
- M6 = 6 mm Swagelok tube fitting
- M1 = 10 mm Swagelok tube fitting
- M2 = 12 mm Swagelok tube fitting
- N4 = 1/4 in. Male NPT
- F4 = 1/4 in. Female NPT

10 Vent Connection

- S4 = 1/4 in. Swagelok tube fitting
- S6 = 3/8 in. Swagelok tube fitting
- S8 = 1/2 in. Swagelok tube fitting
- M6 = 6 mm Swagelok tube fitting
- M1 = 10 mm Swagelok tube fitting
- M2 = 12 mm Swagelok tube fitting
- N4 = 1/4 in. Male NPT
- F4 = 1/4 in. Female NPT

11 Options

- C = Captured pressure regulator vent
- H = Helium leak test
- E = ASME 3.1 material certification

Note: Multiple options can be added to the end of an ordering number.

SGP continued

Dimensions

Dimensions, in inches (millimeters), are for reference only and are subject to change.

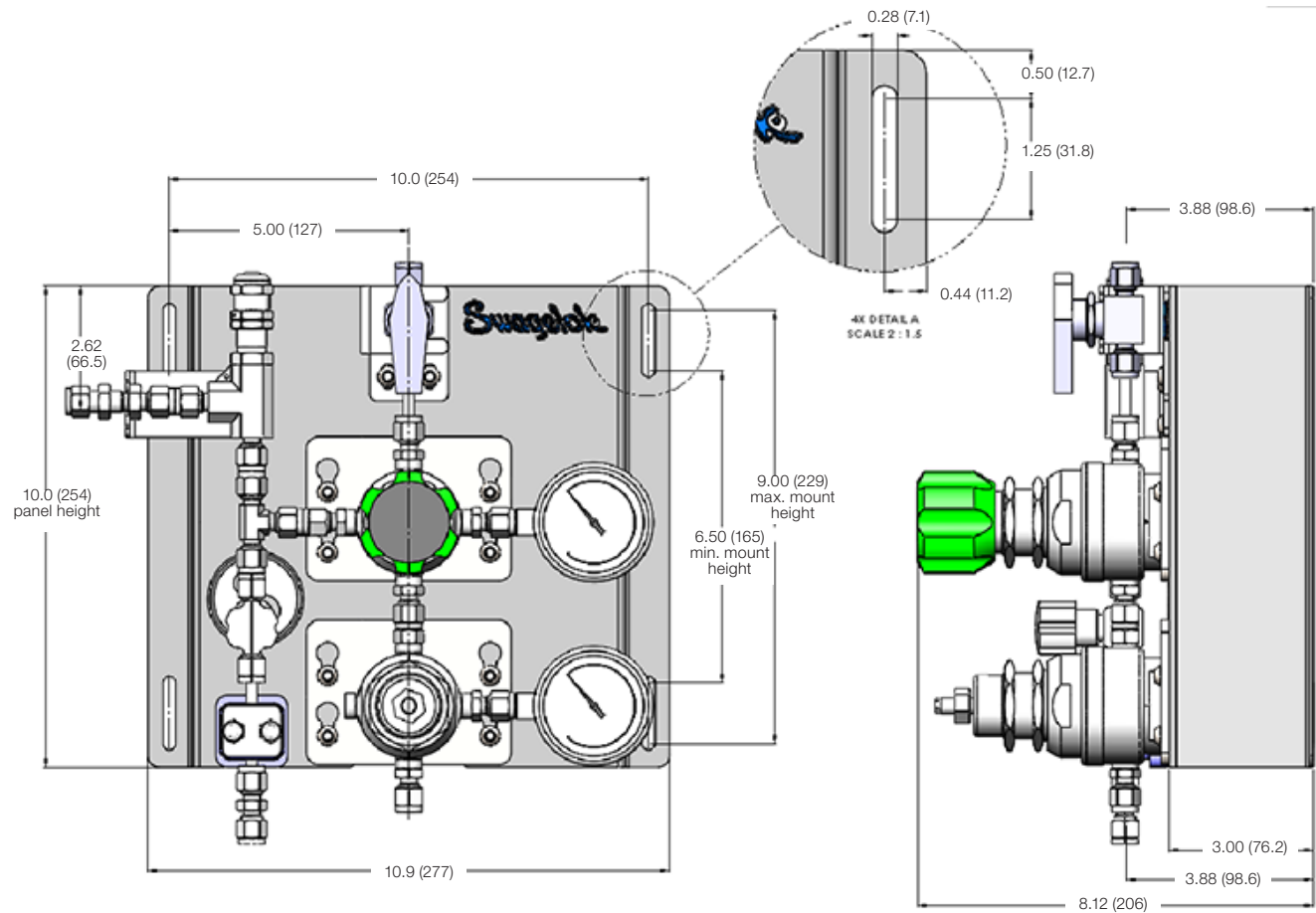

Dual-stage SGP shown. Dimensions are the same for single-stage systems.

Point-of-Use System (SPU)

Swagelok's Point-of-Use Gas Control System (SPU) is the last point of control prior to the gas being used. Used at the end of a gas distribution system, point-of-use systems supply gas to lab benches, vent hoods, and single or small collections of equipment. Gas is fed to point-of-use systems either from a site supply header or from individual gas bottles after having the pressure reduced through a primary gas control system (SGP). Swagelok's SPU systems are available with several bracket options to enable wall, benchtop, or underdesk mounting. They also can be ordered with top-to-bottom or bottom-to-top flow path configurations to accommodate installations that can vary widely between sites, buildings, or even within the same system.

SPU features include:

- Compact mounting brackets to ensure easy installation even within laboratories where wall space can be at a premium
- Easy serviceability, minimizing downtime if maintenance is needed

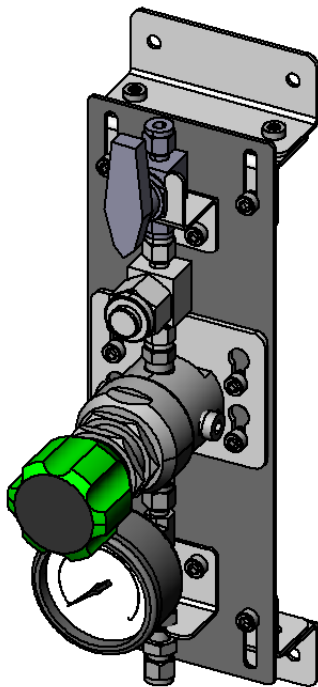

Fig. 12 SPU with Top-to-Bottom Flow

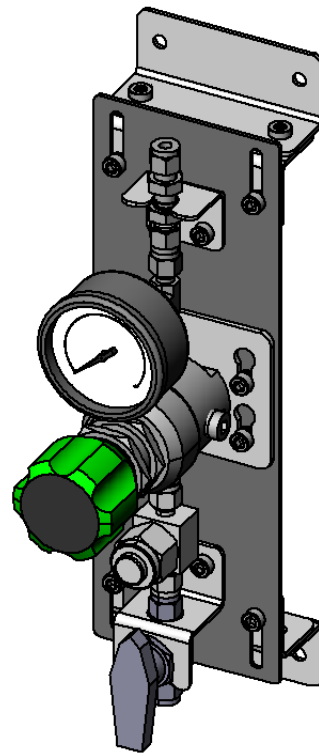

Fig. 13 SPU with Bottom-to-Top Flow

System may include:

- KPR series pressure regulator
- 40 series ball valve
- Swagelok tube fittings
- Seamless tubing
- PGI series gauges (63C)
- TF series filter
- Panel
- Bracket/misc hardware

SPU continued

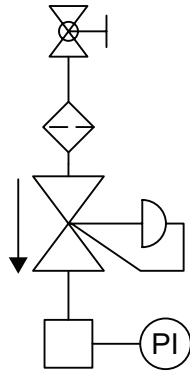

Fig. 14 Standard SPU P&ID

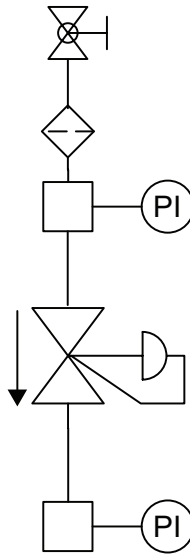

Fig. 15 SPU with Filter and Gauge P&ID

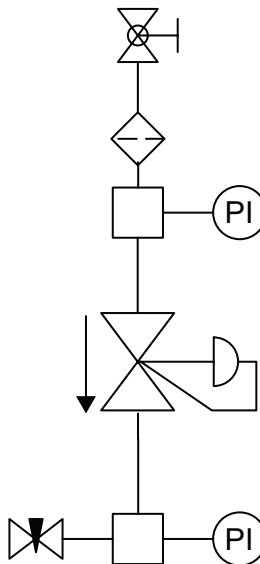

Fig. 16 SPU with Filter, Gauge, and Low-Pressure Vent P&ID

SPU continued

Ordering Information

Build an ordering number by combining the designators in the sequence shown below.

SPU **1** **2** **3** **4** **5** **6** **7** **8** **9** **10** **11** **12**
N **T** **O** **E** **S4** **S4** **4** **0** **X** **0** **5** **E**

1 Gas Type

N = Inert
H = Hydrogen
O = Oxygen^①

① A gas type of oxygen may limit selections available for other components.

2 Flow Direction

T = Top-to-Bottom
B = Bottom-to-Top

3 Gauges

O = Outlet only
B = Inlet and Outlet

4 Pressure Control Range

D = 0 to 25 psig (0 to 1.7 bar)
E = 0 to 50 psig (0 to 3.4 bar)
F = 0 to 100 psig (0 to 6.8 bar)
G = 0 to 250 psig (0 to 17.2 bar)

5 Inlet Connection

S4 = 1/4 in. Swagelok tube fitting
S6 = 3/8 in. Swagelok tube fitting
S8 = 1/2 in. Swagelok tube fitting
M6 = 6 mm Swagelok tube fitting
M1 = 10 mm Swagelok tube fitting
M2 = 12 mm Swagelok tube fitting
N4 = 1/4 in. Male NPT
F4 = 1/4 in. Female NPT

6 Outlet Connection

S4 = 1/4 in. Swagelok tube fitting
S6 = 3/8 in. Swagelok tube fitting
S8 = 1/2 in. Swagelok tube fitting
M6 = 6 mm Swagelok tube fitting
M1 = 10 mm Swagelok tube fitting
M2 = 12 mm Swagelok tube fitting
N4 = 1/4 in. Male NPT
F4 = 1/4 in. Female NPT

7 Inlet Isolation Valve

0 = No valve
4 = 1/4-turn valve
L = Lockable 40 series ball valve
X = 3-way ball valve
T = Lockable 3-way ball valve
D = Multiturn needle valve

8 Vent

0 = No vent
D = Multiturn downstream vent

9 Inlet Filter (7 micron)

X = None
7 = Filter

10 Mounting

0 = Flat plate
W = Wall-mount wings
T = Top (L plate)
B = Bottom (L plate)

11 Regulator C_v (Flow Coefficient)

1 = 0.02
2 = 0.06
5 = 0.2
7 = 0.5

12 Options

C = Captured pressure regulator vent
H = Helium leak test
E = ASME 3.1 material certification

Note: Multiple options can be added to the end of an ordering number.

SPU continued

Dimensions

Dimensions, in inches (millimeters), are for reference only and are subject to change.

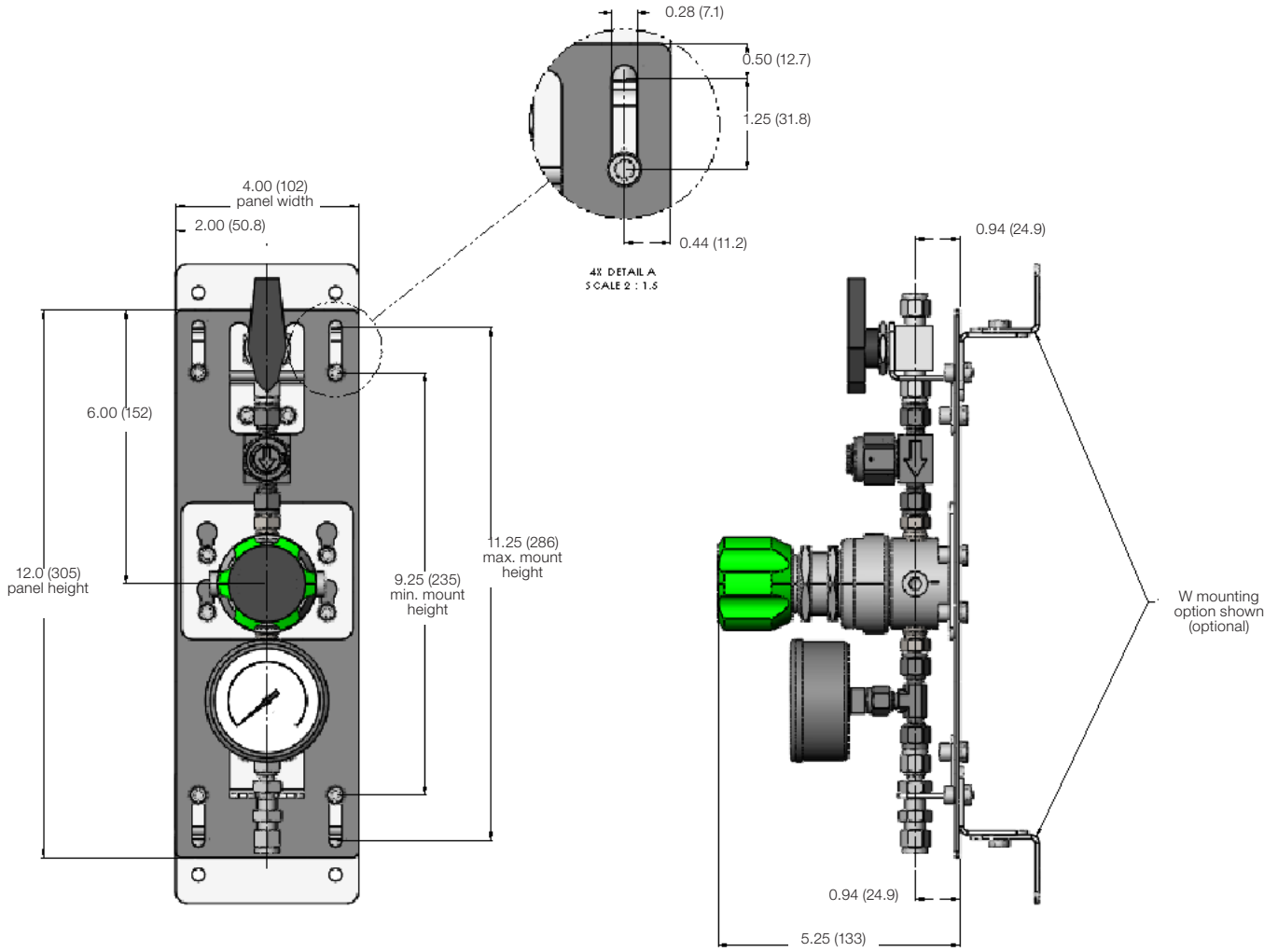

Point-of-Use System (SPU)

Automatic Changeover System (SCO)

An automatic changeover system (SCO) is a special type of Primary Gas Control System used when the continuous supply of gas is important. The SCO system switches from a primary to a secondary source of gas when the pressure of the primary source is below the set changeover pressure. Once the system is drawing from the secondary source, operators can isolate and replace or refill the primary source while gas is still being supplied to the system.

SCO features include:

- A tied changeover handle design, enabling a wide range of changeover pressures
- Easy serviceability, minimizing downtime if maintenance is needed

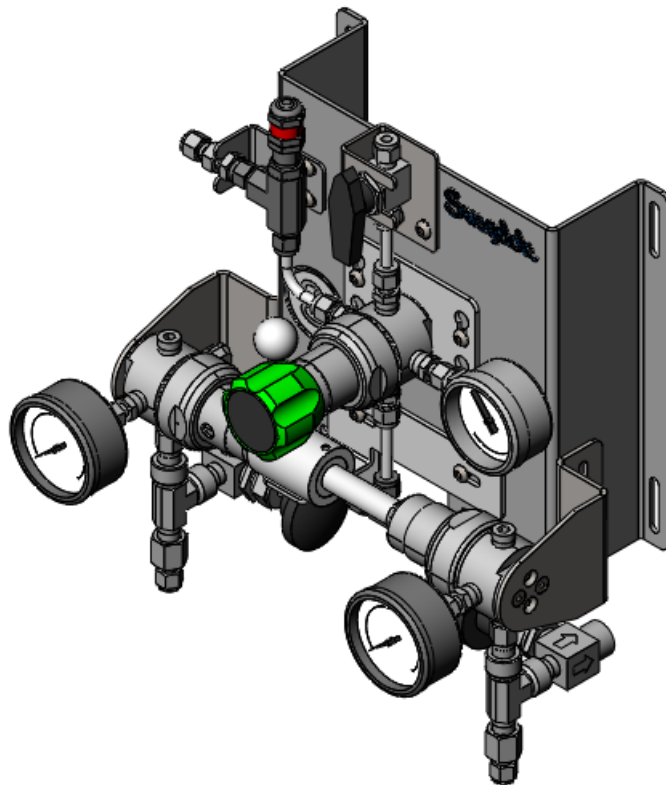

Fig. 17 SCO with Outlet Pressure Regulator

SCO continued

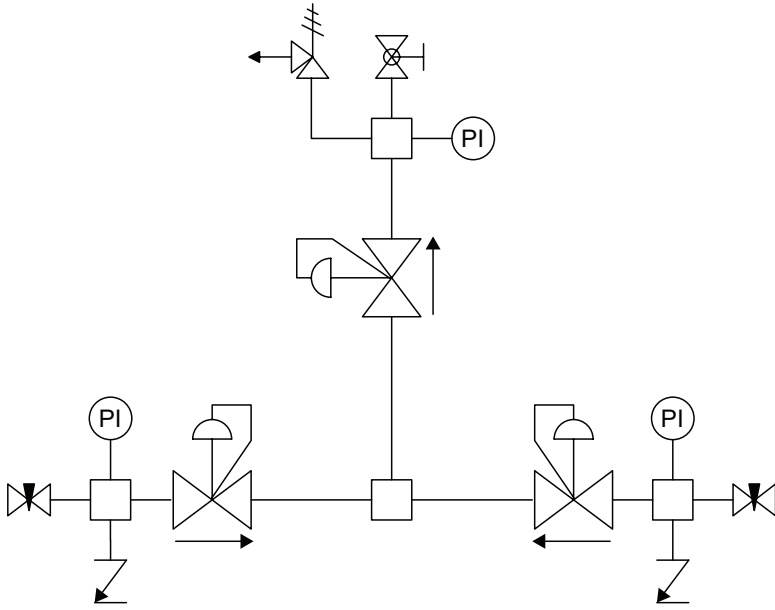

Fig. 18 SCO P&ID with Outlet Pressure Regulator

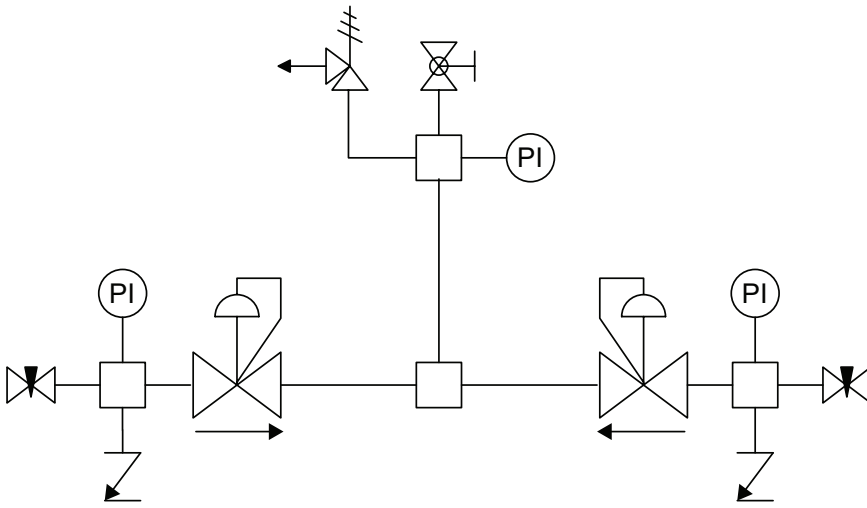

Fig. 19 SCO P&ID without Outlet Pressure Regulator

SCO continued**Ordering Information**

Build an ordering number by combining the designators in the sequence shown below.

SCO **1** **2** **3** **4** **5** **6** **7** **8** **9** **10** **11** **12** **13**
 N F R 2 5 P S4 S4 5 L 1 0 E

1 Gas Type

- N = Inert
- H = Hydrogen
- O = Oxygen[Ⓢ]

[Ⓢ] A gas type of oxygen may limit selections available for other components.

2 Outlet Control Range

- 0 = None
- F = 0 to 100 psig (0 to 6.8 bar)
- G = 0 to 250 psig (0 to 17.2 bar)
- J = 0 to 500 psig (0 to 34.3 bar)

3 Maximum Inlet Pressure

- L = 1000 psig (68.9 bar)
- R = 3600 psig (248 bar)
- T = 4351 psig (300 bar)

4 5 Changeover Pressure

ex. 25 (bar)

6 Unit for Changeover Pressure

- P = psig
- B = bar

7 Inlet Connection

- S4 = 1/4 in. Swagelok tube fitting
- S8 = 1/2 in. Swagelok tube fitting
- M6 = 6 mm Swagelok tube fitting
- M1 = 10 mm Swagelok tube fitting
- M2 = 12 mm Swagelok tube fitting
- F4 = 1/4 in. Female NPT

8 Outlet Connection

- S4 = 1/4 in. Swagelok tube fitting
- S6 = 3/8 in. Swagelok tube fitting
- S8 = 1/2 in. Swagelok tube fitting
- M6 = 6 mm Swagelok tube fitting
- M1 = 10 mm Swagelok tube fitting
- M2 = 12 mm Swagelok tube fitting
- N4 = 1/4 in. Male NPT
- F4 = 1/4 in. Female NPT

9 C_v (Flow Coefficient)

- 1 = 0.02
- 2 = 0.06
- 5 = 0.2
- 7 = 0.5

10 Outlet Isolation Valve

- 0 = No valve
- 4 = 1/4-turn valve
- L = Lockable 1/4-turn ball valve
- D = Multiturn needle valve

11 Inlet Vent

- 1 = Captured
- 2 = Noncaptured

12 Pressure Relief Valve

- 0 = None
- 1 = 4R3A series relief valve
- 2 = Country/regional standard
- X = Customer specified

13 Options

- C = Captured pressure regulator vent (on all system regulators)
- H = Helium leak test
- E = ASME 3.1 material certification

Note: Multiple options can be added to the end of an ordering number.

SCO continued**Dimensions**

Dimensions, in inches (millimeters), are for reference only and are subject to change.

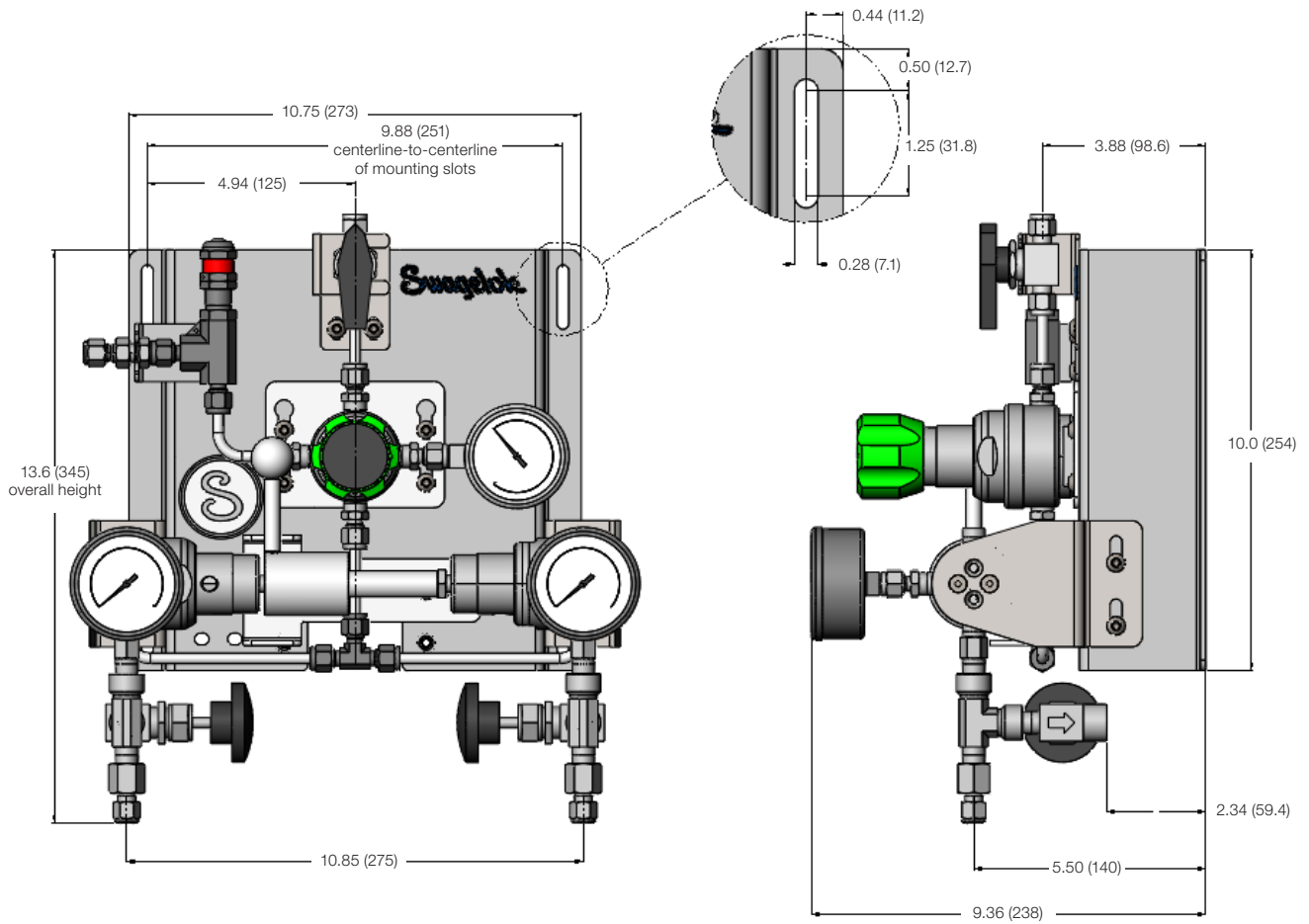

Advisory Services

Already have a gas distribution system but are unsure of its effectiveness? Are you working to refit your space with a new gas distribution system? Looking for a better way to keep your existing systems running well? Swagelok's gas distribution advisors can help evaluate existing systems, select the most effective components for new systems, and develop specific equipment management programs based on the needs of your facility. Contact your local Swagelok sales and service center to get connected with a gas distribution advisor.

Safe Product Selection

When selecting a product, the total system design must be considered to ensure safe, trouble-free performance. Function, material compatibility, adequate ratings, proper installation, operation, and maintenance are the responsibilities of the system designer and user.

 WARNING

Do not mix/interchange Swagelok products or components not governed by industrial design standards, including Swagelok tube fitting end connections, with those of other manufacturers.

Warranty Information

Swagelok products are backed by The Swagelok Limited Lifetime Warranty. For a copy, visit swagelok.com or contact your authorized Swagelok representative.