

Field Station Module

Application Guide

**A Swagelok® Pre-Engineered
Subsystem**

- Pre-engineered subsystems available in weeks, not months.
- Field-tested design ensures optimum system performance.



- Preconditions a gas sample at the extraction point
- Is highly configurable to match process conditions
- Can mount directly to process nozzles

Swagelok®

Swagelok Pre-Engineered Subsystems

Swagelok now offers a series of predesigned and preassembled subsystems for use in all types of plants and facilities where fluids are being processed. Use Swagelok pre-engineered subsystems to create fully documented fluid sampling and control systems and bring consistency to your operations. Easy to install and operate, these subsystems offer the high quality and support you expect from Swagelok.

Contents

<i>Why Use a Field Station Module?</i>	<i>3</i>
<i>Field Station Module Basics</i>	<i>5</i>
<i>Installing a Field Station Module</i>	<i>6</i>
<i>Specifying a Field Station Module</i>	<i>7</i>
<i>Joule-Thomson Cooling Effect</i>	<i>8</i>
<i>Materials of Construction</i>	<i>9</i>
<i>Configurations</i>	<i>10</i>
<i>Technical Data</i>	<i>13</i>
<i>Testing</i>	<i>13</i>
<i>Cleaning and Packaging</i>	<i>13</i>
<i>Dimensions</i>	<i>14</i>
<i>Enclosure Options</i>	<i>16</i>
<i>Heating Options</i>	<i>19</i>
<i>Ordering Information</i>	<i>21</i>
<i>Accessories</i>	<i>22</i>
<i>Regulatory Compliance</i>	<i>24</i>

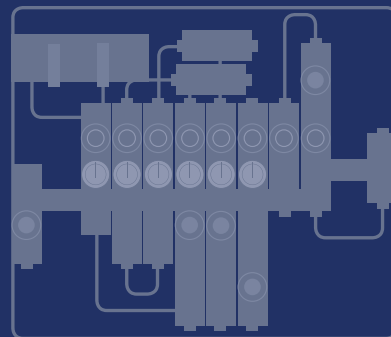
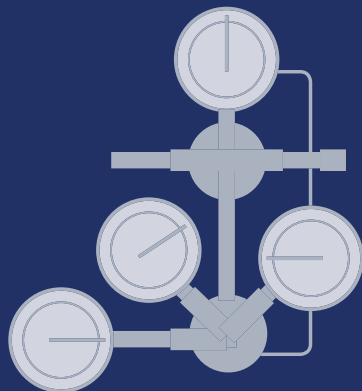
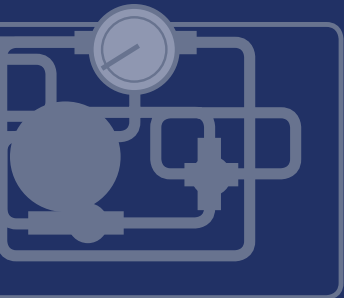

The Swagelok Field Station Module (FSM)

Why Use a Field Station Module?

A Swagelok field station module (FSM) reduces process gas pressure before transporting it to an analyzer. Transporting a gas sample at low pressure offers three major benefits:

- Faster analyzer response time
- Less condensation
- Safer environment

Faster Analyzer Response Time

In a high-pressure line with downstream flow control, gas molecules are more densely populated which creates slower flow velocity and longer purge times. Lowering the pressure of a gas sample means fewer molecules in the sample transport line and sample conditioning components; therefore, it is easier to flush the system, and the analyzer can respond faster to process changes.



Typical Swagelok Field Station Module (FSM)

Without FSM—Slow Response

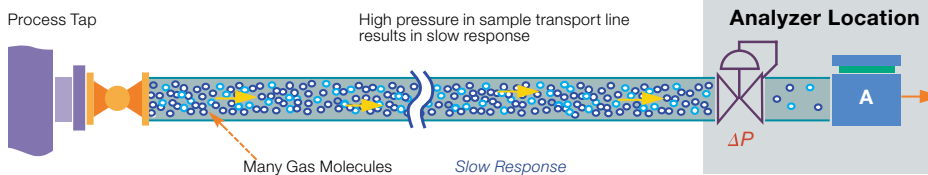

With FSM—Fast Response

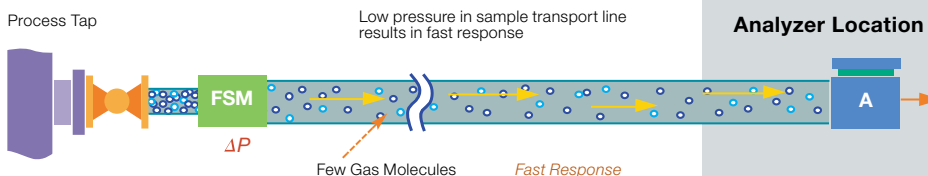

The amount of gas held in the transport line is proportional to its absolute pressure. At half the absolute pressure, there are half as many gas molecules in the line, so—all other things being equal—it takes half the time for a fresh sample to reach the analyzer.

Typically, an FSM is used when process pressure is 3 bar (gauge) (43.5 psig) or higher.

Less Condensation

The relative humidity of a gas is directly proportional to the partial pressure of water vapor in the mixture. A relative humidity (or saturation) of 100 % represents the maximum partial pressure of water vapor possible at a working temperature. Therefore, if water vapor in any gas mixture reaches 100 % of its saturation limit, water vapor will begin to condense in a sample transport line.

To avoid condensation in gas sampling, the FSM reduces the partial pressure of every gas in the sample mixture. One way to lower partial pressure of every gas is to reduce overall system pressure; the partial pressure of each gas drops in proportion to the overall pressure change. For example, if the absolute pressure of a sample is cut in half, the partial pressure of each gas in the mixture is cut in half as well, which results in half the water saturation in the sample. Using an FSM significantly reduces the chance of condensation forming in the sample transport line.

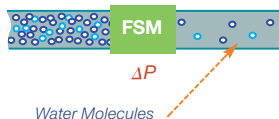

Safer Environment

If a system is compromised, the pressurized gas will expand to atmospheric pressure rapidly and can cause system damage or personal injury. The volumetric expansion ratio is directly proportional to the absolute pressure decrease.

In high-pressure systems without field station modules, the expansion can be so great that the result is explosive in nature. Installing an FSM at the process sampling point means a smaller section of the sample system is exposed to high pressure, resulting in a safer overall environment.

Field Station Module Basics



PR (Pressure Regulator)

The main purpose of a Swagelok FSM is to reduce the pressure of an extracted gas sample prior to transportation to an analyzer. Various Swagelok KPR series regulators are offered to match the wide range of sample conditions. The system volume upstream of the regulator is kept to a minimum to maintain the fastest response time possible.

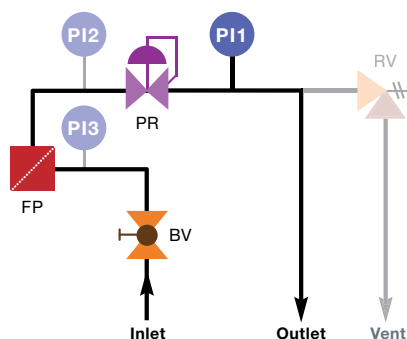

FP (Filter-Particulate)

It is recommended to filter all samples prior to a pressure regulator. Swagelok offers a wide range of particulate filters (FP), membrane filters (FM), and coalescing filters (FC) to accommodate various particulate loads and sample moisture levels.

Where it is desirable to reduce high-pressure volume even further, the FSM can be ordered without a filter. In this case, an integral filter is included in the inlet side of the regulator.



BV (Ball Valve)

To allow for fast and local shutoff of an FSM, all configurations include a Swagelok 40G series ball valve at the inlet of the system.



PI (Pressure Indicator)

Swagelok includes gauges in three different pressure indicator locations for convenient troubleshooting.

- PI1 location measures outlet pressure of the regulator.
- Optional PI2 location measures inlet pressure of the regulator.
- Optional PI3 location measures FSM inlet pressure (assumed to be process pressure).
- PI2—PI1 locations measure the pressure drop across the regulator to ensure proper regulator function.
- PI3—PI2 locations measure the pressure drop across the filter to help indicate when filter maintenance is needed.



RV (Relief Valve)

The Swagelok FSM is available with an optional proportional relief valve to guard the rest of the analytical system from a drastic increase in pressure downstream of the regulator.

Installing a Field Station Module

The schematic below illustrates an FSM installed in a process line.

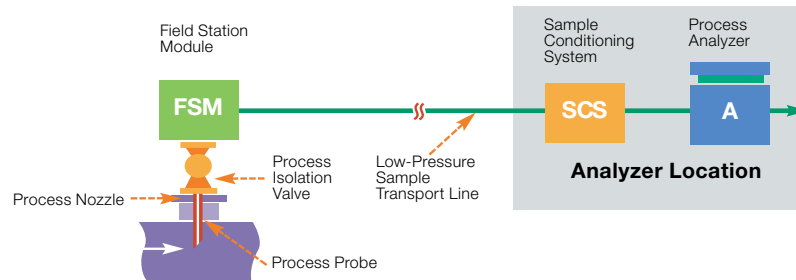

For faster analysis, mount the FSM on top of the process nozzle (as shown above). If direct mounting on the nozzle is impractical or inconvenient, install the FSM close to the process nozzle (as shown below). Keep the connecting tube that links the probe to the FSM as short as possible. Because the connecting tube contains gas at full process pressure, it is important to minimize its volume to maintain the fastest response time to the analyzer.

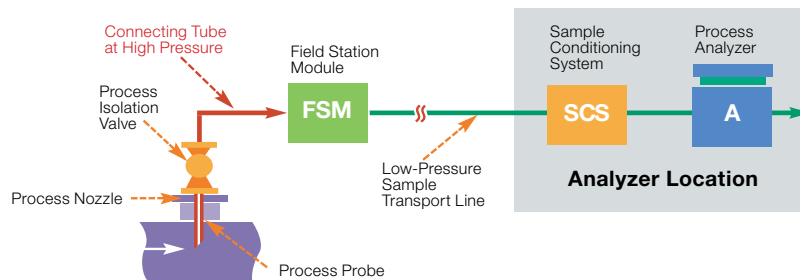

For more information about installation, operation, and maintenance of Swagelok FSM subsystems, see the *Field Station Module User's Manual*, MS-13-218.

Specifying a Field Station Module

The FSM can be customized to meet system requirements. To specify an FSM:

- Know the maximum inlet pressure of the FSM. Specify the FSM configuration with the lowest inlet pressure that is compatible with the highest process pressure.
- Specify pressure gauge dial size, placement, and fill. The measurement ranges of the pressure gauges are determined automatically from the inlet pressure.
- Swagelok selects the regulator that is suitable for the maximum inlet pressure. The outlet pressure control range is 0 to 50 psig (0 to 3.4 bar) for all models.
- Choose from five filter or coalescer options: no separate filter, small- or large-particle filter, membrane separator with gravity drain, and large fibrous coalescer with membrane filter.
 - Coalescer options work to remove liquid mist. The coalescer drain may terminate in a manual blowdown valve that is separate from this system.
 - Do not use a coalescer if the sample contains many particulates; the coalescer will clog. Instead, specify a filter to remove them and, if the liquid mist is volatile, keep the field station and transport line hot enough to avoid condensation. If necessary, condense and remove the liquid in the sample conditioning system close to the analyzer. If the sample contains many particulates and nonvolatile liquid mist, the FSM may not be suitable; ask for an evaluation by Swagelok.
- Select from three pressure-relief options: no relief valve, preset adjustable relief valve, or preset adjustable relief valve with manual override handle.

⚠ Caution: Without a relief valve, the outlet pressure gauge and the downstream equipment are not protected if the pressure regulator fails. A suitable pressure relief mechanism should be used to protect the system from overpressurization.

- Choose from a wide range of inlet and outlet connections, including Swagelok tube fittings, NPT fittings, and flanges.
- Select an enclosure option. ABS plastic, fiberglass, and 304 stainless steel enclosures and sun shades are available. Enclosures are available with or without a window and insulated or uninsulated.

Joule-Thomson Cooling Effect

Field station modules with inlet pressures of 1000 psig (68.9 bar) or higher have a large pressure drop, and the sample may experience excessive cooling. Although the temperature drop caused by Joule-Thomson cooling is the same at any flow rate, the heat it absorbs is proportional to the rate of flow. The FSM offers a wide range of heater options, sufficient for most sampling applications.



Materials of Construction

Configuration Label	Component	Manufacturer, Model	Material Grade / ASTM Specification
BV	Isolation ball valve	Swagelok 40G series	See Swagelok <i>One-Piece Instrumentation Ball Valves—40G Series and 40 Series</i> catalog, MS-02-331
FC	Filter-coalescing membrane (configuration 5)	Avenger™ model 38M	See Avenger 30 Series Filters selection guide, www.apluscorporation.com
FM	Filter-membrane separator (configuration 3)	Supreme model 123HP	See Series 100 Genie® Membrane Separators™ selection guide, www.apluscorporation.com
FP	Filter-particulate (small capacity, configurations 1 and 2)	Swagelok TF series	See Swagelok <i>Filters</i> catalog, MS-01-92
	Filter-particulate (large-capacity, configuration 4)	Avenger model 38	See Avenger 30 Series Filters selection guide, www.apluscorporation.com
PI	Pressure indicator	Swagelok B model pressure gauge	See Swagelok <i>Pressure Gauges, Industrial and Process—PGI Series</i> catalog, MS-02-170
PR	Pressure regulator	Swagelok KPR series	See Swagelok <i>Pressure Regulators</i> catalog, MS-02-230
RV	Relief valve, proportional	Swagelok RL3 and R3A series	See Swagelok <i>Proportional Relief Valves</i> catalog, MS-01-141
System Hardware and Optional Components			
—	Base plate	Swagelok	304 SS / A240
—	Flange fittings	Swagelok	See Swagelok <i>Flange Adapters</i> catalog, MS-02-200
—	Hardware	Various	300 series SS, electroplated steel, hot-dip galvanized steel, or coated steel
—	Mounting brackets	Swagelok	304 SS / A240
—	Stainless steel tube fittings	Swagelok	316 SS / A276 or A182 See Swagelok <i>Gaugeable Tube Fittings and Adapter Fittings</i> catalog, MS-01-140
—	Stainless steel tubing	Swagelok	316/316L SS / A213/A269 See Swagelok <i>Stainless Steel Seamless Tubing</i> catalog, MS-01-1-SCS
—	Stainless steel enclosure	Swagelok	304 SS / A240
—	ABS enclosure	O'Brien VIPAK® A1	See O'Brien Corporation VIPAK catalog, www.obcorp.com
—	Fiberglass enclosure	Intertec DIABOX™ 87	See Intertec Instrumentation DIABOX 87 catalog www.intertec.info/
—	Stainless steel sun shade	Swagelok	304 SS / A240
—	ABS sun shade	O'Brien VIPAK E1B	See O'Brien Corporation VIPAK catalog, www.obcorp.com
—	Fiberglass sun shade	Intertec SD 50	See Intertec Instrumentation SD 50 Shade catalog, www.intertec.info/
—	Enclosure heater	Intertec CP MULTITHERM	See Intertec Instrumentation explosion proof convection heaters, www.intertec.info/
—	Regulator heater	Intertec SL BLOCKTHERM	See Intertec Instrumentation explosion proof conduction heaters, www.intertec.info/
—	Thermostat	Intertec TS and TAE	See Intertec Instrumentation DIABOX 87 catalog, www.intertec.info/
—	Thermometer	Swagelok	See Swagelok <i>Temperature Measurement Devices</i> catalog, MS-02-353

Configurations

1. Clean, Dry, High-Pressure

Specially designed to minimize sample system volume upstream of the pressure drop. This is especially important in high-pressure systems where upstream molecules travel at extremely slow velocities.

- Lowest internal volume upstream of the regulator (PR).
- Optional PI2 gauge measures inlet pressure at the regulator.
- Optional small-capacity particle filter (FP).
- Fastest response for sample systems.



Shown with
Stainless Steel
Enclosure Base

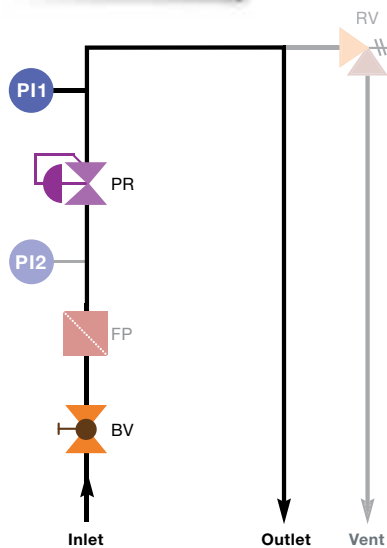

2. Clean, Dry, Medium Pressure

Designed for clean, dry samples in medium- to high-pressure systems. Volume upstream of the regulator is kept to a minimum, however gauges are assembled in a vertical orientation, allowing for an upstream filter gauge.

- Low internal volume.
- Optional PI2 gauge measures inlet pressure at the regulator.
- Optional PI3 gauge allows pressure drop measurement across the filter, which helps indicate when filter maintenance is needed.
- Optional small-capacity particle filter (FP).

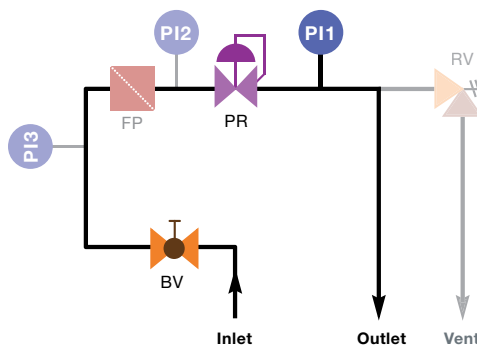

Configurations

3. Low Moisture and Particulate Load

Designed for process lines with low levels of moisture and particulate load.

- Low internal volume maintained in this design.
- Membrane separator (FM) with integral gravity drain allows moisture to drop back to process.
- Maximum recommended flow rate through membrane separator is 0.18 std ft³/min (5.1 std L/min).
- Optional PI2 gauge measures inlet pressure at the regulator.

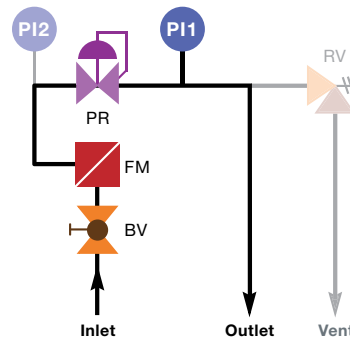

4. High Particulate Load

Handles highest particulate load of any configuration.

- Optional PI3 gauge allows pressure drop measurement across the filter, which helps indicate when filter maintenance is needed.
- Includes large-capacity particle filter (FP).
- Optional PI2 gauge measures inlet pressure at the regulator.

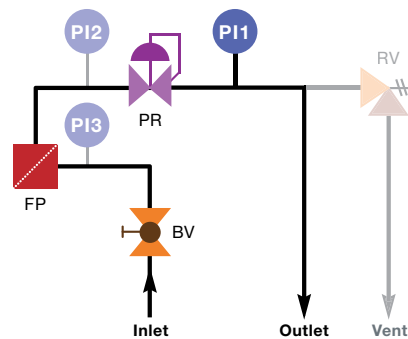

Configurations

5. Moist Process Sample

Includes coalescing filter and liquid drain for moist process samples.

- Higher internal volume.
- Large-capacity 0.1 μm coalescing filter and membrane separator combination filter (FC).
- Maximum recommended flow rate through membrane separator is 0.035 std ft^3/min (1.0 std L/min).
- Optional PI2 gauge measures inlet pressure at the regulator.
- Optional PI3 gauge allows pressure drop measurement across the filter, which helps indicate when filter maintenance is needed.

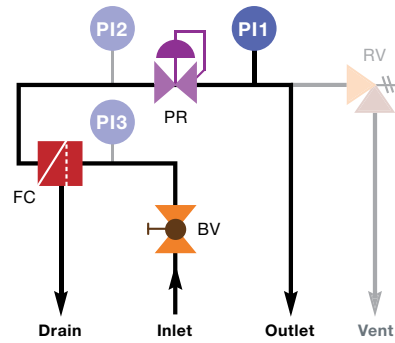

Technical Data

FSM Configuration	Working Pressure psig (bar)	Temperature Rating, °F (°C)		Maximum Air Flow std ft ³ /min (std L/min)		Filter Internal Volume in. ³ (cm ³)
		With Relief Valve	Without Relief Valve	15 psig (1.0 bar) Outlet Pressure	30 psig (2.1 bar) Outlet Pressure	
1 Clean, dry, high-pressure	2500 (172)	250 (121)	300 (148)	0.23 (6.5)	0.39 (11.0)	0.30 (4.9)
2 Clean, dry, medium-pressure	2500 (172)	250 (121)	300 (148)	0.23 (6.5)	0.39 (11.0)	0.30 (4.9)
3 Low moisture and particulate load	1000 (68.9)	185 (85)	185 (85)	0.18 (5.1)	0.18 (5.1)	0.56 (9.1)
4 High particulate load	1000 (68.9)	250 (121)	300 (148)	0.23 (6.5)	0.39 (11.0)	3.05 (50.0)
5 Moist process sample	1000 (68.9)	185 (85)	185 (85)	0.035 (1.0)	0.035 (1.0)	3.05 (50.0)

For systems outside these parameters, contact your authorized Swagelok sales and service representative.

Testing

Every Swagelok FSM subsystem is shell tested with nitrogen at 145 psig (10 bar) to a requirement of no detectable leakage with a liquid leak detector.

Cleaning and Packaging

All Swagelok FSM subsystems are cleaned in accordance with Swagelok *Standard Cleaning and Packaging (SC-10)*, MS-06-62.

Dimensions

Dimensions, in inches (millimeters), are for reference only and are subject to change.

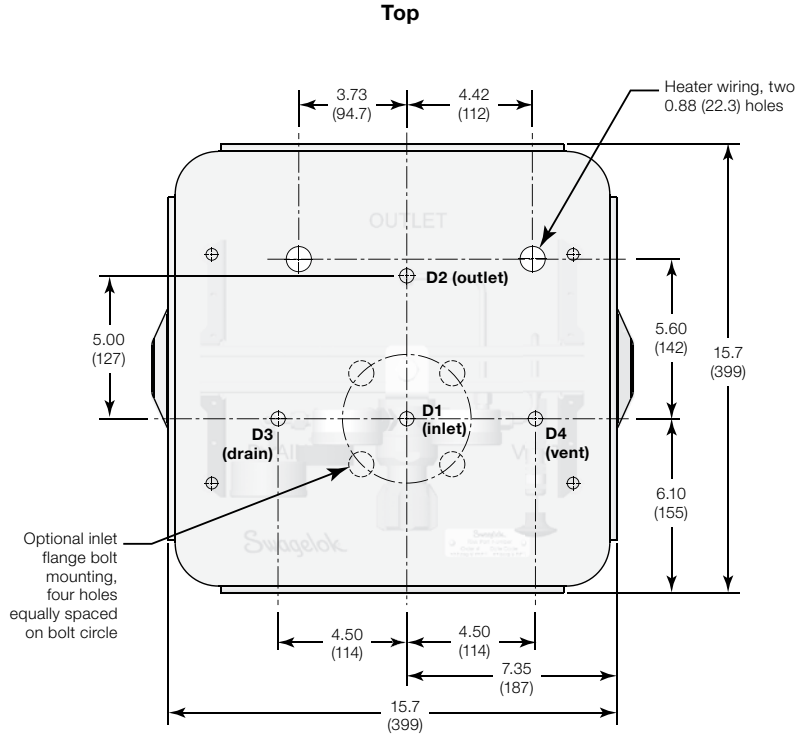

End Connections			Base Plate Dimensions in. (mm)	
Type	Size	ASME Pressure Class	D1, D2 Dia	D3, D4 Dia
Swagelok tube fitting	1/4 in.	—	0.50 (12.7)	0.50 (12.7)
	6 mm	—		
Female NPT	1/4 in.	—		
	1/2 in.	—		
Entry seal ^①	2 in.	—		
Tube stub ^②	1/4 in.	—	0.50 (12.7)	
Flange ^③	3/4 in.	150	1.50 (38.1)	
		600		
		1500		
	1 1/2 in.	150		
		600		
		1500		

Weight

FSM Subsystem	Weight lb (kg)
Basic module	25 (11.3)
Stainless steel enclosure	35 (15.9)
ABS enclosure	20 (9.1)
Fiberglass enclosure	25 (11.3)
Heater	10 (4.5)
Stainless steel sun shade	9.0 (4.1)
ABS plastic sun shade	6.5 (2.9)
Fiberglass sun shade	8.0 (3.6)

① Entry seal includes inlet and outlet fittings with heat-shrinkable seal to accommodate 0.75 to 1.6 in. (19.0 to 40.6 mm) insulated tubing.

② All connections on FSM subsystems with ABS plastic or fiberglass enclosures are 1/4 in. tube stubs.

③ Flange available for inlet connection *only*.

Dimensions

Dimensions, in inches (millimeters), are for reference only and are subject to change.

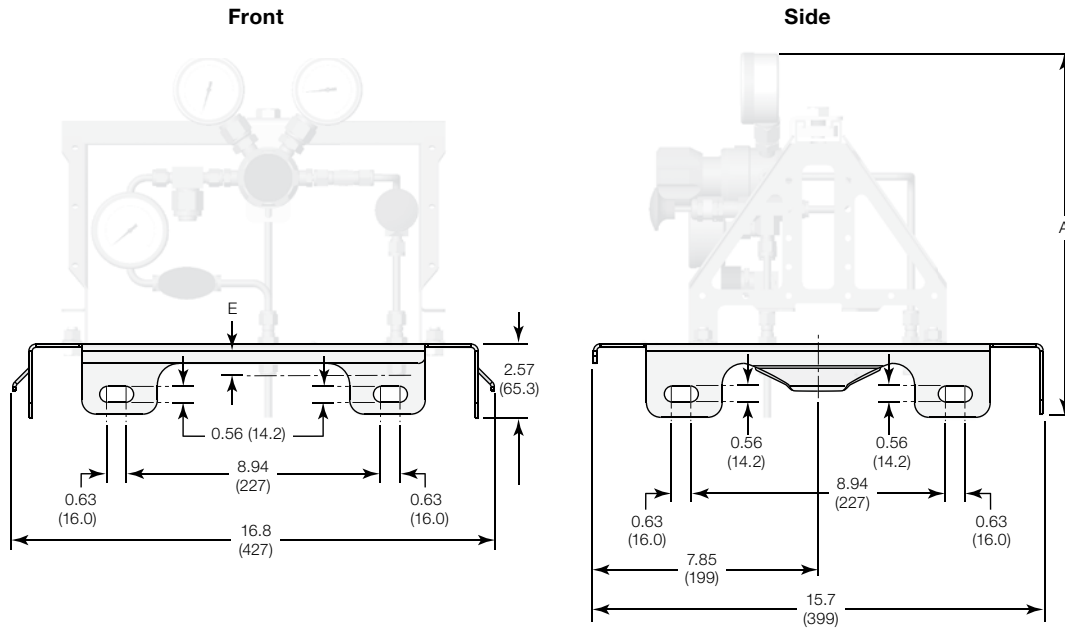

End Connections		E, in. (mm)
Type	Size	
Swagelok tube fitting	1/4 in.	0.95 (24.1)
	6 mm	
Female NPT	1/4 in.	0.72 (18.3)
	1/2 in.	0.97 (24.6)
Entry seal ^①	2 in.	5.10 (130)
Tube stub ^②	1/4 in.	2.00 (50.8)
Flange ^③	3/4 in.	0.51 (13.0)
		0.88 (22.4)
		1.26 (32.0)
	1 1/2 in.	0.70 (17.8)
		1.14 (29.0)
	1.51 (38.4)	

① Entry seal includes inlet and outlet fittings with heat-shrinkable seal to accommodate 0.75 to 1.6 in. (19.0 to 40.6 mm) insulated tubing.

② All connections on FSM subsystems with ABS plastic or fiberglass enclosures are 1/4 in. tube stubs.

③ Flange available for inlet connection *only*.

FSM Configuration	A, in. (mm)	
	63 mm (2 1/2 in.) Gauge	100 mm (4 in.) Gauge
1 Clean, dry, high-pressure	14.8 (376)	16.4 (417)
2 Clean, dry, medium-pressure	12.6 (320)	14.6 (371)
3 Low moisture and particulate load	15.9 (404)	17.8 (452)
4 High particulate load		
5 Moist process sample		

Enclosure Options

Enclosures

Three types of enclosures, all with lockable latches to secure them in the closed position, are available to protect Swagelok FSM subsystems.

304 Stainless Steel

Stainless steel enclosures, manufactured by Swagelok, are IP55 rated. They are mounted to the FSM base plate and have three positions: closed, open, and removed.

- Neoprene foam rubber provides a weather-resistant seal.
- Stainless steel handles and a force-assist gas spring allow the enclosure to be readily raised into the open position. In the open position, the enclosure provides unique 360° access for easy adjustments and service. For full access, the enclosure can be completely removed by disengaging the gas-assist spring and lifting on the handles.
- Enclosures insulated with 1 in. (25.4 mm) thick closed-cell foam rubber are available for heated applications.
- A safety-glass or polycarbonate 10.2 by 12.2 in. (259 by 310 mm) window option provides a large viewing area.



ABS (Acrylonitrile Butadiene Styrene) Plastic

ABS VIPAK enclosures are manufactured by O'Brien Corporation and are IP66 rated.

- Neoprene gasketed door, 1 in. (25.4 mm) urethane insulation, stainless steel prop rod, and two 1 5/8 in. horizontal mounting struts on the back are included.
- Window option includes 12.0 by 12.0 in. (305 by 305 mm) tempered glass window centered on the front.



Fiberglass

Fiberglass DIABOX enclosures are manufactured by Intertec Instrumentation and are IP65/NEMA4X rated.

- EPDM-gasketed door, stainless steel prop rod, and two 1 5/8 in. horizontal mounting struts on the back are included.
- Insulation option includes 1 in. (25.4 mm) low-density polyurethane.
- Window option includes 11.4 by 11.4 in. (290 by 290 mm) safety-glass or acrylic window centered on the front.



Enclosure Options

Dimensions

Dimensions, in inches (millimeters), are for reference only and are subject to change.

304 Stainless Steel

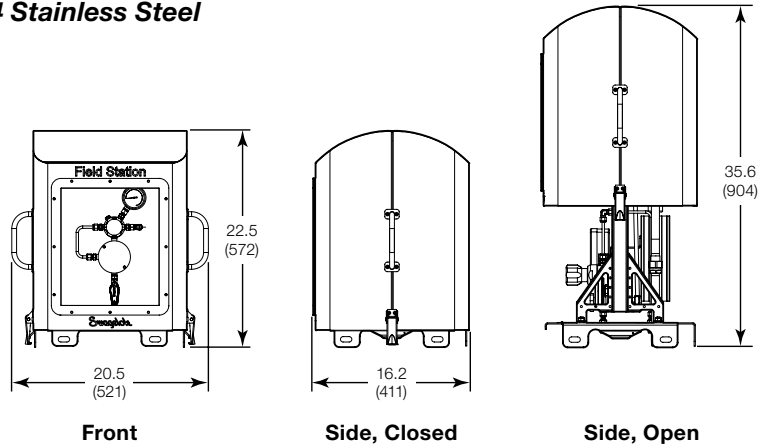

ABS Plastic

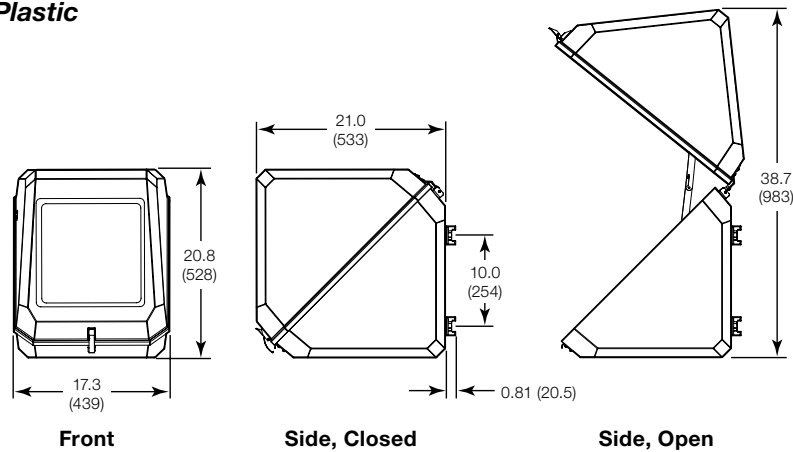

Fiberglass

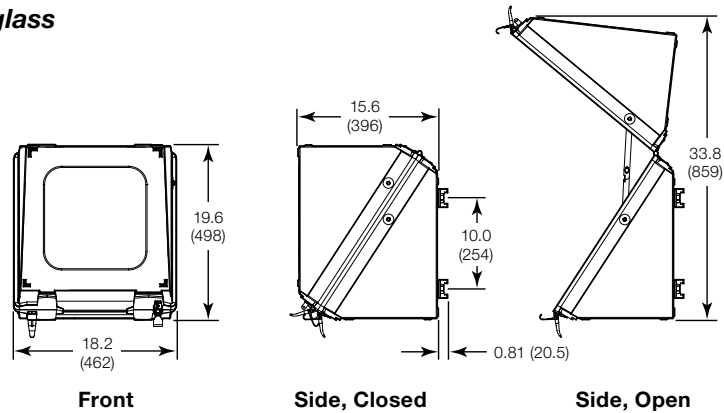

Enclosure Options

Sun Shades

As an alternative to enclosures, sun shades are available in 304 stainless steel, ABS plastic, and fiberglass.

- Stainless steel sun shades are manufactured by Swagelok.
- ABS plastic sun shades are manufactured by O'Brien Corporation.
- Fiberglass sun shades are manufactured by Intertec Instrumentation.

Material	Dimensions, in. (mm)	Mounting
304 SS	Mounted: 22.4 H, 20 W, 20 D (569 H, 508 W, 508 D)	Mounts to the FSM brace in place of an enclosure
ABS plastic	Unmounted: 19.5 H, 17 W, 19.5 D (495 H, 432 W, 495 D)	Mount to a 2 in. structural pipe (not supplied); two pipe clamps and mounting hardware provided
Fiberglass	Unmounted: 7.0 H, 22.4 W, 22.4 D (178 H, 569 W, 569 D)	



Stainless Steel Sun Shade



ABS Plastic Sun Shade Shown with Mounting Bracket (Available Separately)



Fiberglass Sun Shade Shown with Mounting Bracket (Available Separately)

Heating Options

Heaters and thermostats for Swagelok FSM subsystems are manufactured by Intertec Instrumentation.

Enclosure Heaters

Heaters are available for applications where environmental temperatures may drop below the dew point of the gas. Heaters are mounted inside the enclosure for freeze protection or temperature maintenance. An insulated enclosure should be ordered with a heater to maximize effectiveness.

Enclosure heaters with thermostats are available with ATEX/IEC or CSA/UL approvals.



Enclosure Heater with Thermostat (ATEX/IEC Approval)

Enclosure Heater with Thermostat (CSA/UL Approval)

Enclosure Heater Selection

Enclosure heaters typically are selected based on the temperature differential (ΔT) between the set thermostat temperature and the lowest expected ambient temperature.

Enclosure Configuration	Maximum ΔT , °F (°C)				
	50 (28)	75 (42)	100 (56)	125 (69)	150 (83)
	Heater Wattage Required				
Stainless Steel Enclosure					
Insulated, no window	100 W	100 W	100 W	200 W	—
Insulated, with window	100 W	100 W	200 W	200 W	—
ABS and Fiberglass Enclosures					
Insulated, no window	50/100 W	50/100 W	100 W	100 W	200 W
Insulated, with window	50/100 W	100 W	100 W	200 W	200 W
Uninsulated, no window ^①	100 W	200 W	—	—	—
Uninsulated, with window ^①	100 W	200 W	—	—	—

① Available in fiberglass only.

Heating Options

Regulator Heaters

Regulator heaters are intended for applications where the Joule-Thomson effect from high pressure drops may cause the regulator to freeze or the gas to condense. Regulator heaters are mounted to the bottom of the pressure regulator body to heat the regulator body and surrounding air.



Regulator Heater

Regulator heaters are self-limiting and are available with ATEX/IEC or CSA/UL approvals.

Heater Thermostats

Heater thermostats provide temperature control of the environment within the enclosure and are available with ATEX/IEC and CSA/UL approvals.



Enclosure heater thermostats are available at 50, 86, and 125°F (10, 30, and 50°C) set temperatures. Regulator heaters are self limiting.

Heater	Control	Power W	Set Temperature °F (°C)
Enclosure	Thermostat	100	50 (10)
			86 (30)
			125 (50)
Enclosure	Thermostat	200	50 (10)
			86 (30)
Regulator	Self-limiting	50	T4 max (275°F [135°C])

Ordering Information

Build an FSM subsystem ordering number by combining the designators in the sequence shown below.

1
2
3
4
5
6
7
8
9
10
11
FSM - 1 - R B 1 A B - S4 S4 SA - XXX 5

1 Configuration

- 1** = Clean, dry, high-pressure (page 10)
- 2** = Clean, dry, medium-pressure (page 10)
- 3** = Low moisture and particulate load (page 11)
- 4** = High particulate load (page 11)
- 5** = Moist process sample (page 12)

2 Maximum Inlet Pressure

Outlet pressure control range is 0 to 50 psig (0 to 3.4 bar) for all models.

- F** = 100 psig (6.8 bar)
- J** = 300 psig (20.6 bar)
- L** = 1000 psig (68.9 bar)
- R** = 2500 psig (172 bar)^①

^① Available on configurations **1** and **2** only.

3 Pressure Gauge Location(s)

Swagelok B Model

- A** = Regulator outlet only
- B** = Regulator inlet and outlet
- C** = Filter inlet and regulator outlet^①
- D** = Filter inlet, regulator inlet, and regulator outlet^①

^① Available on configurations **2**, **4** and **5** only.

4 Pressure Gauge Dial Size, Fill

Swagelok B Model

- 1** = 63 mm (2 1/2 in.), unfilled
- 2** = 63 mm (2 1/2 in.), silicone fill
- 3** = 100 mm (4 in.), unfilled^①
- 4** = 100 mm (4 in.), silicone fill^①

^① Filter inlet gauge has a 63 mm (2 1/2 in.) dial.

5 Filter

- A** = 15 µm TF series particle filter (configurations **1** and **2** only)
- X** = No separate filter, 25 µm gauze inlet filter on regulator
- Y** = *Required* for configurations **3**, **4**, and **5**

6 Relief Valve

- A** = Pre-set^① adjustable relief valve
- B** = Pre-set^① adjustable relief valve, manual override handle
- X** = No relief valve

^① For 100 and 300 psig (6.8 and 20.6 bar) systems, RL3 relief valve is factory set to 45 psig (3.1 bar); for 1000 and 2500 psig (68.9 and 172 bar) systems, R3A relief valve is factory set to 50 psig (3.4 bar).

7 Inlet Connection

Bulkhead

- S4** = 1/4 in. Swagelok tube fitting
- 6M** = 6 mm Swagelok tube fitting
- F4** = 1/4 in. female NPT
- F8** = 1/2 in. female NPT

Tube

- ES** = Entry seal (includes removable 1/4 in. tube stub)
- T4** = 1/4 in. tube stub (removable)

Flange (Not available on ABS plastic and fiberglass enclosures)

- B1** = 3/4 in., ASME class 150^①
- B3** = 3/4 in., ASME class 600^②
- B5** = 3/4 in., ASME class 1500
- D1** = 1 1/2 in., ASME class 150^①
- D3** = 1 1/2 in., ASME class 600^②
- D5** = 1 1/2 in., ASME class 1500

^① Limits pressure to 275 psig (18.9 bar).

^② Limits configurations **1** and **2** to 1440 psig (99.2 bar).

8 Outlet, Drain, Vent Connections

Bulkhead (304 SS enclosure only)

- S4** = 1/4 in. Swagelok tube fitting
- 6M** = 6 mm Swagelok tube fitting
- F4** = 1/4 in. female NPT

Tube

- ES** = Entry seal outlet (includes removable 1/4 in. tube stub); removable 1/4 in. tube stub drain and vent)
- T4** = 1/4 in. tube stub (removable)

9 Enclosure (page 16) /

Sun Shade (page 18)

- XX** = No enclosure, no sun shade

304 Stainless Steel Enclosure

- SA** = Uninsulated, no window
- SB** = Uninsulated, safety glass window
- SC** = Uninsulated, polycarbonate window
- SE** = Insulated, no window
- SF** = Insulated, safety glass window
- SG** = Insulated, polycarbonate window

ABS Plastic Enclosure

- AE** = Insulated, no window
- AF** = Insulated, safety glass window

Fiberglass Enclosure

- GA** = Uninsulated, no window
- GB** = Uninsulated, safety glass window
- GD** = Uninsulated, acrylic window
- GE** = Insulated, no window
- GF** = Insulated, safety glass window
- GH** = Insulated, acrylic window

Sun Shade

- AS** = ABS plastic
- GS** = Fiberglass
- SS** = 304 stainless steel

10 Heater (page 19) /

Thermostat (page 20)

XXX = No heater, no thermostat

Approval^{①②③}

Thermostat

Enclosure Heater, 100 W

(convection heater, T3)

- 1A1** = ATEX/IEC 230 V 50°F (10°C)
- 1A3** = ATEX/IEC 230 V 86°F (30°C)
- 1A5** = ATEX/IEC 230 V 122°F (50°C)
- 1C1** = CSA/UL D1 120 V 50°F (10°C)
- 1C3** = CSA/UL D1 120 V 86°F (30°C)
- 1C5** = CSA/UL D1 120 V 122°F (50°C)
- 1D1** = CSA/UL D1 230 V 50°F (10°C)
- 1D3** = CSA/UL D1 230 V 86°F (30°C)
- 1D5** = CSA/UL D1 230 V 122°F (50°C)

Enclosure Heater, 200 W

(convection heater, T3)

- 2A1** = ATEX/IEC 230 V 50°F (10°C)
- 2A3** = ATEX/IEC 230 V 86°F (30°C)
- 2C1** = CSA/UL D1 120 V 50°F (10°C)
- 2C3** = CSA/UL D1 120 V 86°F (30°C)
- 2D1** = CSA/UL D1 230 V 50°F (10°C)
- 2D3** = CSA/UL D1 230 V 86°F (30°C)

Regulator Heater, 50 W

(conduction heater, self-limiting, T4, 110 to 265 V range for most applications)

- 5BX** = ATEX/IEC 265 V None
- 5EX** = CSA/UL D2 265 V None

^① Heater and thermostat approvals:

ATEX/IEC 230 V—II 2G/D EEx d IIC, (230 V)
ATEX/IEC 265 V—II 2G/D EEx d IIC, (110 to 265 V)
CSA/UL D1 120 V—CI I; Div 1; A, B, C, D (120 V)
CSA/UL D1 230 V—CI I; Div 1; A, B, C, D (230 V)
CSA/UL D2 265 V—CI I; Div 2; A, B, C, D (110 to 265 V)

^② Included ATEX junction box is II 2G EEx e II T6 rated.

^③ Included CSA/UL junction box is suitable for gas groups A, B, and C only.)

11 Additional Options

For multiple options, add numerical, then alphabetical designators.

- 5** = Swagelok bimetal thermometer, 0 to 200°F (–15 to 90°C), 3 in. (76 mm dial size)
- K** = SWAK[®] thread sealant on NPT threads (PTFE tape is standard)

Accessories

Mounting Brackets

A variety of brackets—including back-center, cantilever, direct, and wall mounting models—is available.

Materials

Component	Material
Split washers, washers, hex bolts, struts, mounting plate, rounded U-bolts, squared U-bolts	300 series SS
Strut nuts	Electrogalvanized steel



FSM with Back-Center Mounting Bracket

Dimensions

Dimensions, in inches (millimeters), are for reference only and are subject to change.

Back-Center (BC) Mounting Bracket Kits

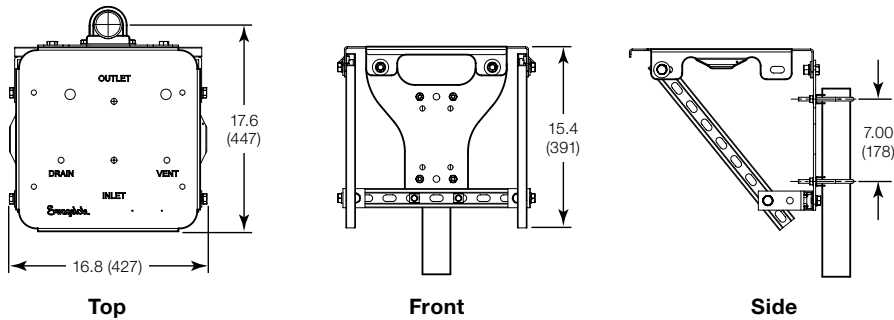

Cantilever (C, CS, CL) Mounting Bracket Kits

These kits are available in center line, short, and long cantilever models.

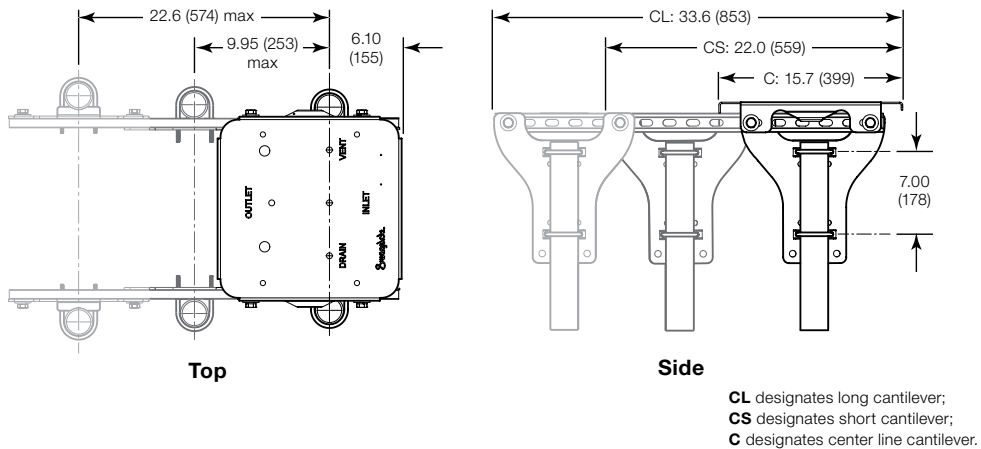

Accessories

Direct (DM) Mounting Bracket Kits

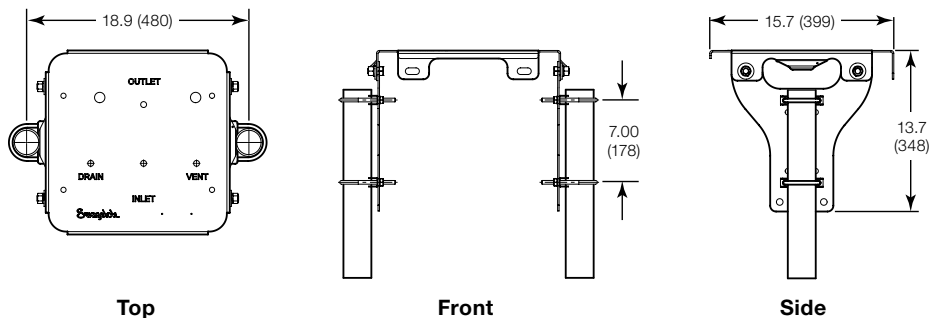

Wall (WM) Mounting Bracket Kits

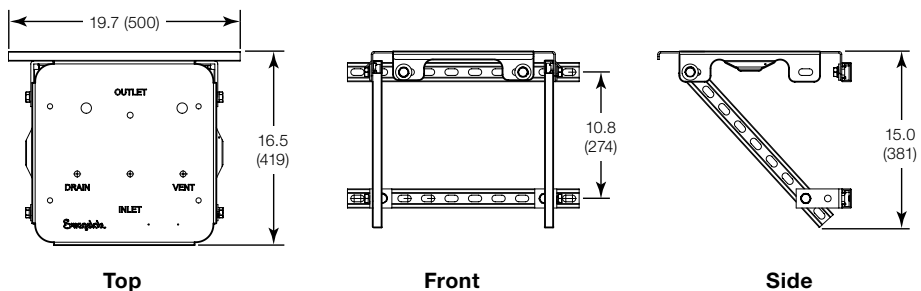

Ordering Information

Build an FSM mounting bracket kit ordering number by combining the designators in the sequence shown below.

1
2
3
 FSM - MK - **BP** - **CS** - **32P**

1 System Type

BP = Base plate
PE = Plastic enclosure (available with back-center mounting style **BC** only)

2 Mounting Style

BC = Back-center (available for support type **32P** only)
C = Center-line cantilever
CL = Long cantilever
CS = Short cantilever
DM = Direct
WM = Wall (does not require support type designator)

3 Support Type

Omit designator for wall mount (**WM**) mounting style.

32P = 2 in. pipe
32S = 2 in. square tube
26S = 1 5/8 in. strut

Accessories

Replacement Filter Element Kits

Kits include filter element and instructions.

FSM Configuration	Kit Ordering Number
1 Clean, dry, high-pressure	SS-4F-K4-15
2 Clean, dry, medium-pressure	
3 Low moisture and particulate load	FSM3-FILTER-K
4 High particulate load	FSM4-FILTER-K
5 Moist process sample	FSM5-FILTER-K

Regulatory Compliance

Europe

- Pressure Equipment Directive (PED) 2014/68/EU
- Atmospheres Explosive Directive (ATEX) 2014/34/EU
- Restriction of Hazardous Substances Directive (RoHS) 2011/65/EU

Americas

- Hazardous location electrical approval (CSA/UL)
- CRN registered in Canada (individual components of assembly)

Contact your authorized Swagelok representative for specific assembly compliance approvals and certifications available from the manufacturer.

Safe Product Selection

When selecting a product, the total system design must be considered to ensure safe, trouble-free performance. Function, material compatibility, adequate ratings, proper installation, operation, and maintenance are the responsibilities of the system designer and user.

Caution: Do not mix or interchange Swagelok product components with those of other manufacturers.

Warranty Information

Swagelok products are backed by The Swagelok Limited Lifetime Warranty. For a copy, visit swagelok.com or contact your authorized Swagelok representative.