

Fig. 1

The Swagelok® integrated test valve assembly is designed to be used with a universally mounted steam trap (not included).

Operating Instructions

For regular system flow, both valves should be in the OPEN position, Fig. 1 above.

To monitor steam trap performance, the isolation valve remains in the OPEN position and the test valve is cycled one-quarter turn to the CLOSED position, Fig. 2.

- If steam trap is operating properly, condensate will be coming from the **test valve vent**.
- If a continuous flow of steam is coming out of the test valve vent, the steam trap is not functioning properly.
- If nothing comes out of the test valve vent, there may be blockage upstream of the vent, or the strainer may need to be cleaned (See page 2). Otherwise the steam trap is no longer functioning properly.

⚠ Position the test valve vent away from operating personnel. Operating personnel must protect themselves from exposure to system fluids.

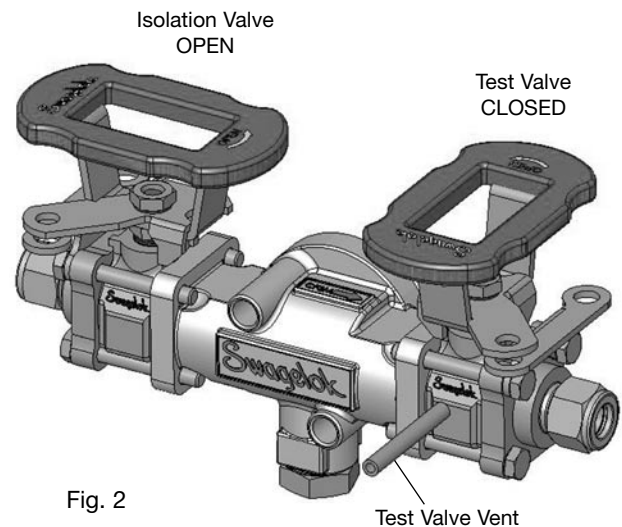

Fig. 2



Maintenance Instructions

Replacing the Steam Trap

1. Start with both valves in the OPEN position.
2. **⚠ Close isolation valve first.**
3. Close test valve. See Fig 3.
4. Replace steam trap bolted to the flange of the universal mount.
5. Test the assembly for proper operation and leaktight sealing. See **Testing** section.

Valve Maintenance

See Swagelok "Maintenance Instructions for 60 and 60X Series 4-Bolt Ball Valves", and follow the instructions for stainless steel 63 series ball valves.

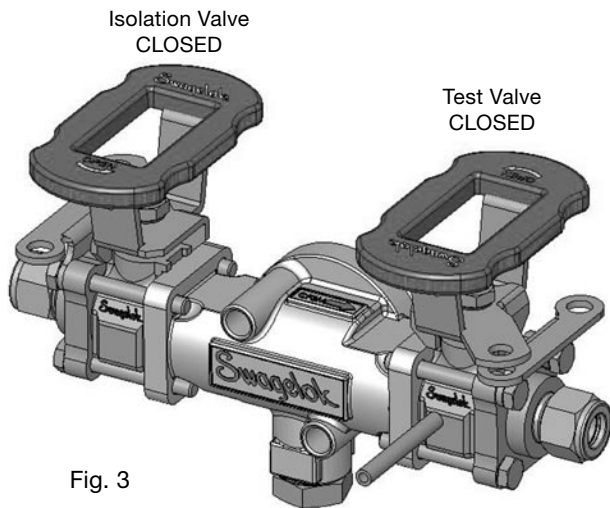

Fig. 3

Testing

1. Open both the isolation and test valves, and allow integrated test valve assembly to return to normal operating temperature.
2. To verify new steam trap is functioning properly, follow the Operating Instructions for monitoring Steam Trap Performance on page 1.

Replacing the Strainer Element

The strainer element in the integrated test valve assembly will require periodic inspection and maintenance. To replace or clean the strainer element, follow these instructions.

1. Start with both valves in the OPEN position.
2. **⚠ Close isolation valve first.**
3. Close test valve. See Fig 3.
4. Unthread the **strainer cap** and remove.
5. Remove the **gasket** and discard.
6. Remove the **strainer element** and clear any debris from element, or replace with a new element.
7. Apply a system-compatible lubricant to all surfaces of a new **gasket**.
8. Install the **strainer element**, the **new gasket**, and the **strainer cap**. See Fig 4.
9. Tighten the **strainer cap** to the body with 500 in.·lb (60 N·m, 575 cm·kg) of torque.
10. Test the assembly for proper operation and leaktight sealing. See **Testing** section.

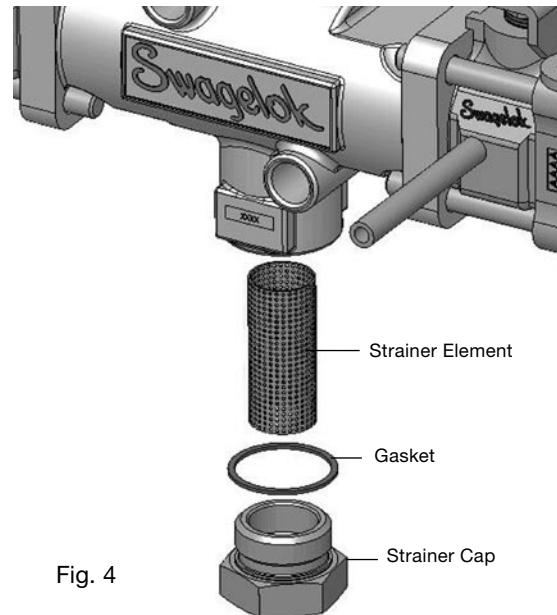

Fig. 4