

# RD(H)20/25 Pressure-Reducing Regulator User Manual

Swagelok



**Read the complete manual before installing and using the regulator.**

## Safe Product Selection

When selecting a product, the total system design must be considered to ensure safe, trouble-free performance. Function, material compatibility, adequate ratings, proper installation, operation, and maintenance are the responsibilities of the system designer and user.



### WARNING

- Users must be trained and equipped for the handling, use, and servicing of pressure products and systems.
- Users must contact their gas or liquid supplier for specific safety precautions and instructions.
- Gaseous media should be free of excessive moisture to prevent icing at high flow.
- Always wear the appropriate protective clothing, including safety glasses, gloves, etc., if required.
- Follow the applicable safety and maintenance procedures.
- Obey specific local regulations.
- Do not exceed the maximum inlet and outlet pressure rating of the product or its accessories.
- Operate within the temperature limits and any other conditions specified for the product.
- Do not drop or damage the product in any other way. This may negatively affect the performance of the product which can cause the product to malfunction.
- Venting fluids and gases can be dangerous. Vent to a safe environment away from people. Ensure adequate ventilation.

## Contents

<b>Introduction</b> .....	<b>4</b>
Overview .....	4
Standard Features .....	4
Additional Options .....	4
Oxygen Service.....	4
<b>Installation</b> .....	<b>5</b>
Points of Attention Before Installation .....	5
Installation .....	5
Dome Pressure Control.....	6
External Feedback .....	9
<b>Operation</b> .....	<b>10</b>
Required Tools for Operation .....	10
Points of Attention Before Operation.....	10
Adjusting the Set Pressure.....	10
<b>Maintenance</b> .....	<b>11</b>
Required Tools for Maintenance .....	11
Points of Attention Before Removal from the System .....	12
Removal from the System.....	12
Assembly Reference Data .....	13
Disassembly .....	18
Points of Attention Before Reassembly.....	18
Reassembly .....	19
RD(H)20 Series: Standard .....	19
RD(H)25 Series: Standard .....	19
RD(H)10 and RD(H)15 Series: External Feedback.....	19
<b>Testing</b> .....	<b>20</b>
Seat Leak Test .....	20
Shell Leak Test.....	20
<b>Troubleshooting</b> .....	<b>21</b>

# Introduction

## Overview

- The RD(H)20 and RD(H)25 series are dome-loaded pressure-reducing regulators designed for the regulation of high pressure, high flow gases and liquids.
- For pressure and temperature rating information refer to the *Pressure Regulators, RHPS Series* catalog, MS-02-430. Note that seat seal material selection can limit the regulator operational pressure at elevated temperatures.



### **WARNING**

**Check that system pressures and temperatures do not exceed those stated on the regulator as this could result in product failure.**

## Standard Features

- Bolted construction
- Stainless steel as standard
- Fully serviceable
- Diaphragm sensing
- Balanced poppet
- Pilot regulator
- Dynamic regulation

## Additional Options

The regulator is available with the following options:

- External feedback to main regulator
- External feedback to pilot regulator
- Anti-tamper pilot regulator

## Oxygen Service

- For more information about hazards and risks of oxygen enriched systems see the *Swagelok Oxygen System Safety* technical report (MS-06-13).
- Cleaning and packaging to ensure compliance with product cleanliness requirements stated in ASTM G93 Level C is available. Refer to the *Pressure Regulators, RHPS Series* catalog, MS-02-430, for additional information.

## Installation



### CAUTION

Do not use the regulator as a shutoff device. A level of leakage across the regulator seat can occur during normal operation.

### Points of Attention Before Installation

This regulator can be equipped with different options and connections. Before installing the regulator you should fully understand the functions of the supplied options and the suitability of your particular regulator for the intended application.

- The preferred mounting position of the regulator is horizontal with the dome facing upwards per Fig 1. Alternative mounting positions may increase the risk of component wear.
- It may be necessary to remove the regulator from the system during maintenance or service. Ensure that this is possible.
- The regulator is suitable for gases and liquids dependent on the options selected. For liquid applications a pilot regulator should not be used. Ensure compatibility between the regulator's materials of construction and the system media.
- Swagelok recommends the use of a non-venting pilot regulator when the process media is hazardous or toxic.

### Installation

- Verify that the regulator, the connections, and its accessories are undamaged.
- Verify that the regulator and its accessories are suitable for the system operating pressure and temperature and have suitable connections.
- At the time of delivery any gauge ports may be plugged with blind fittings. Remove these and connect gauges if desired.
- If inlet/outlet fittings are being used, assemble them to the regulator, per the manufacturer's instructions, prior to installing the regulator in the system.



### CAUTION

Ensure all upstream tubing/pipework is clean and free from debris. Any swarf, lint, wire, etc. may damage the regulator, resulting in a seat leak.

- Verify the flow direction of the system and mount the regulator accordingly.
- Securely make the appropriate connections to the regulator in accordance with the procedures recommended by the connection manufacturer.
- Ensure that the tubing/pipework and the regulator are adequately supported and that there is no stress on the connections.
- Upstream and downstream shutoff valves should be installed in the system to facilitate servicing, maintenance, and troubleshooting of the regulator.



### WARNING

When using an RDH20 or RDH25 with an inlet pressure higher than 2900 psig (200 bar), a safety valve must be installed in the outlet line to ensure the outlet pressure does not exceed 2900 psig (200 bar), which could result in product failure.

## Dome Pressure Control

The dome pressure of the regulator controls the outlet pressure. There are several methods available for supplying and controlling the dome pressure.

- **Integral pilot control.** In this setup the dome-loaded regulator comes supplied with a pilot regulator as part of the assembly (Fig 1). The pilot regulator, fed from the system pressure, is manually operated to control the dome pressure (Fig 2). This setup is not suitable for liquid applications.
- **External dome control.** In this setup the dome pressure is supplied from an independent source, such as a cylinder or main supply (Fig 3). This setup is suitable for liquid applications.
- **Electronic control.** In this setup an electronic pilot regulator, fed from the system pressure, is used in conjunction with a pressure transducer to directly control the dome pressure (Fig 4). The outlet pressure of the main regulator will be limited by the outlet pressure of the electronic regulator. This setup is not suitable for liquid applications.
- **Ratio control.** In this setup a ratio pilot regulator, fed from the system pressure, is used to control the dome pressure. The ratio pilot can be controlled by an electronic regulator and pressure transducer combination (Fig 5) or by an external dome feed. The ratio pilot outlet pressure is proportionally larger than its sensing pressure. This enables the main regulator to achieve full outlet pressure while being controlled from a low pressure supply. This setup is not suitable for liquid applications.

The best performance will be achieved by allowing a small flow to continuously pass through the pilot regulator. This flow can either be vented through an orifice (Fig 3) or, in gas systems, fed back through an orifice into the downstream piping (Fig 2). This is usually referred to as “dynamic regulation”.

### NOTICE



**It is not recommended to place a gauge on the dome to set or check the outlet pressure. Because of forces in the regulator, the dome pressure will differ slightly from the outlet pressure. Place a gauge in the outlet line to set or check the outlet pressure.**

### Integral Pilot Assembly

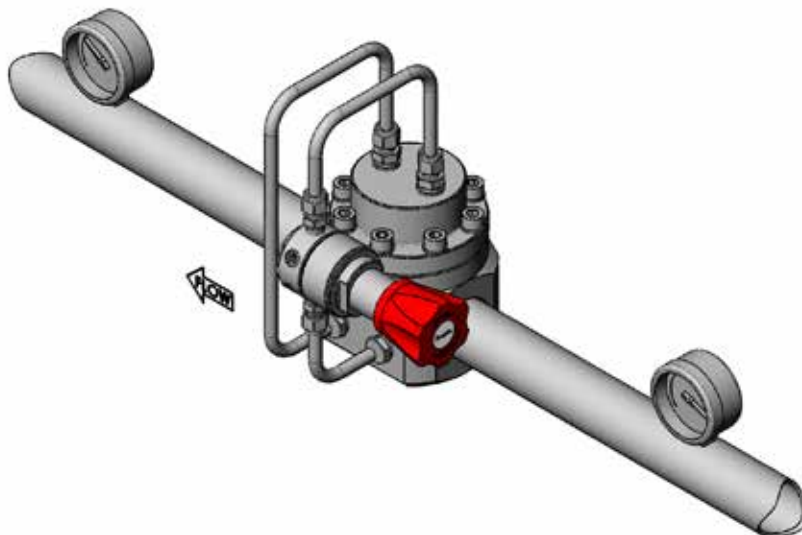

Fig 1

**Integral Pilot Control Schematic**

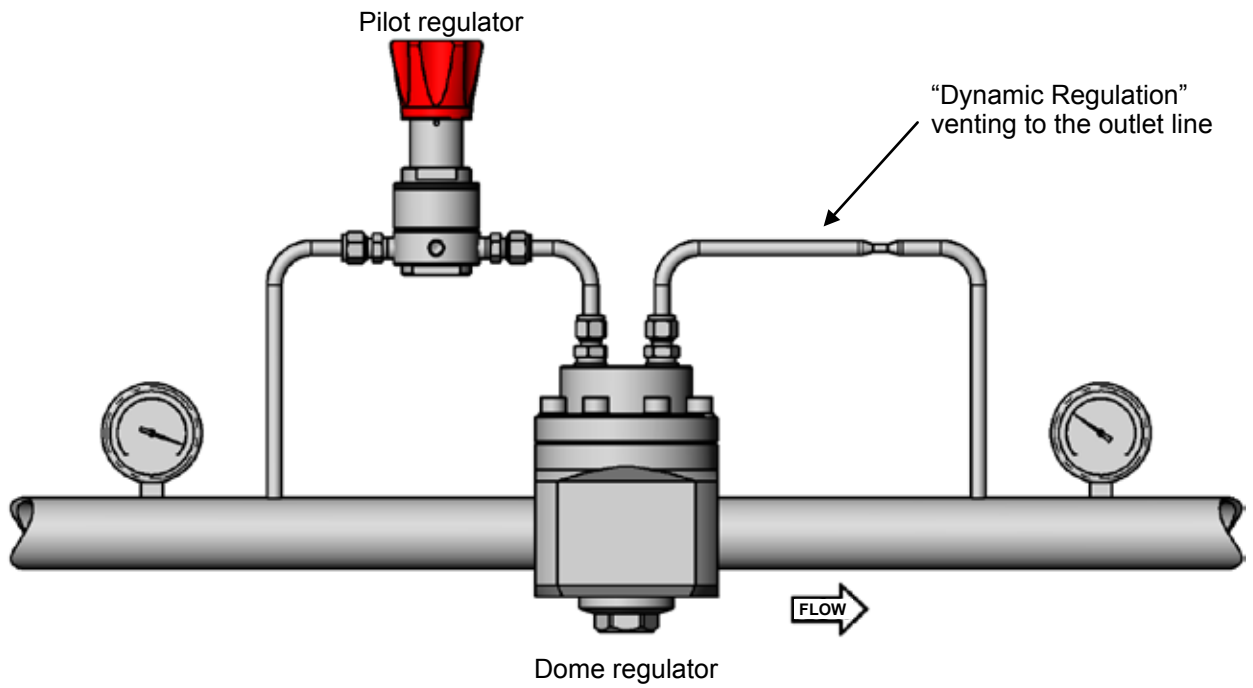

Fig 2

**External Dome Control Schematic**

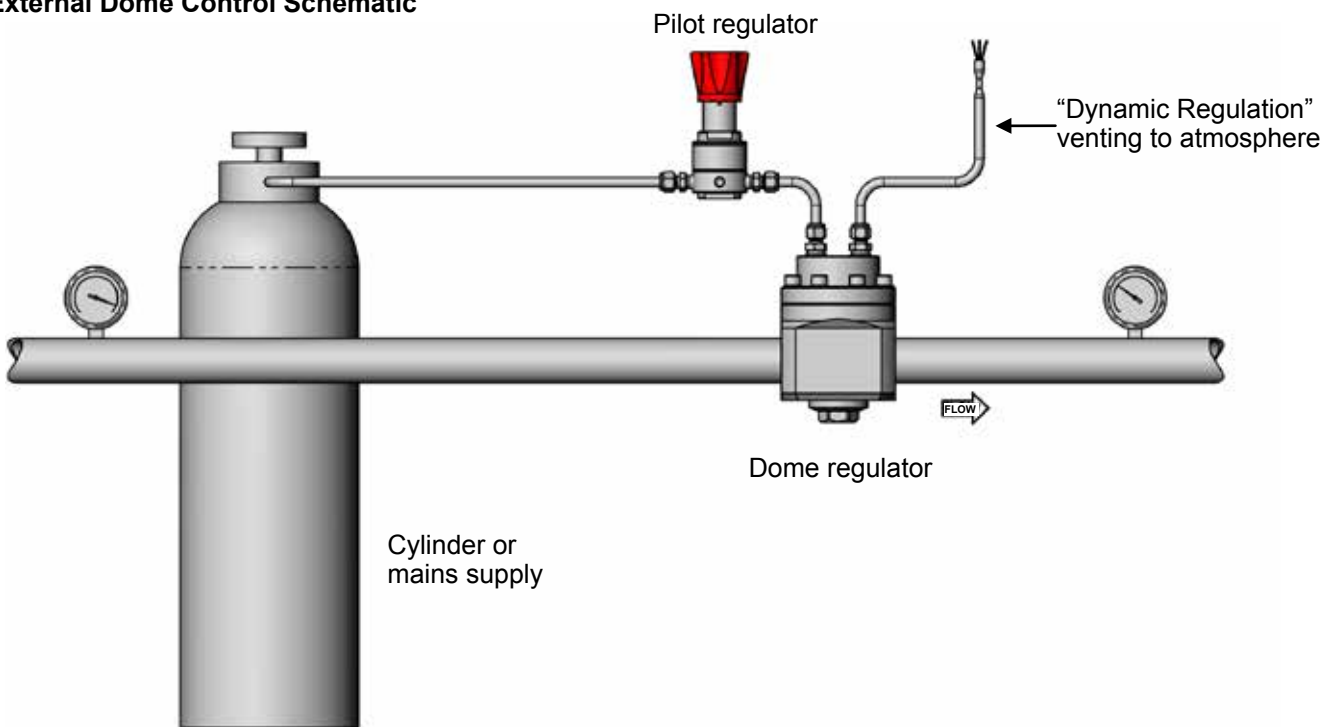
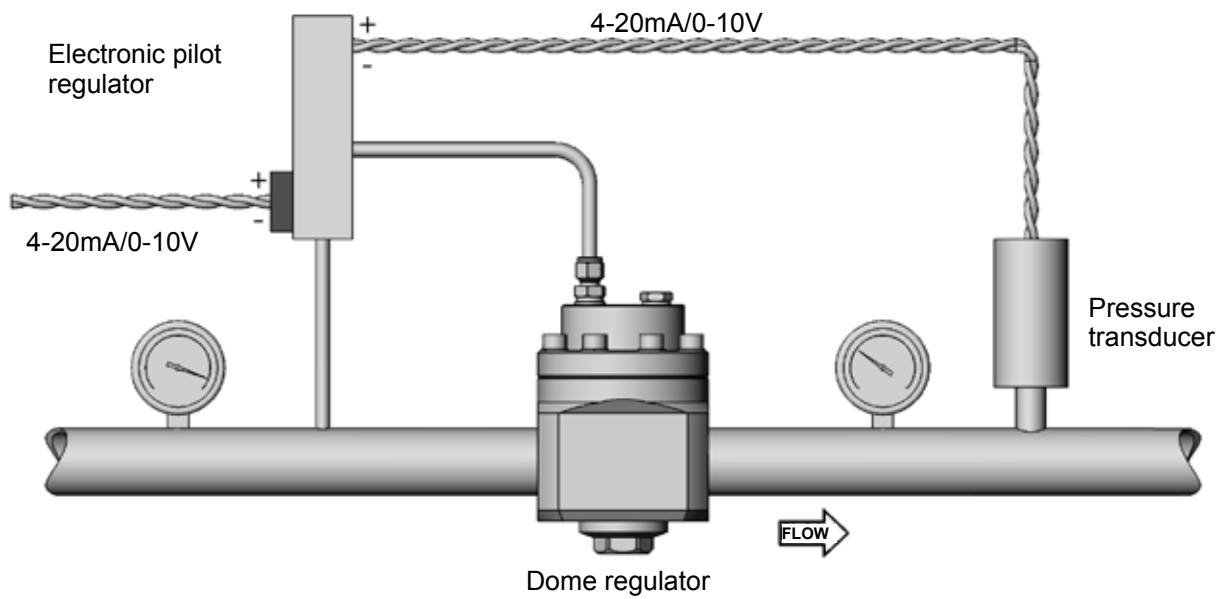

Fig 3

### Electronic Control Schematic



Dome regulator

Fig 4

### Ratio Control Schematic

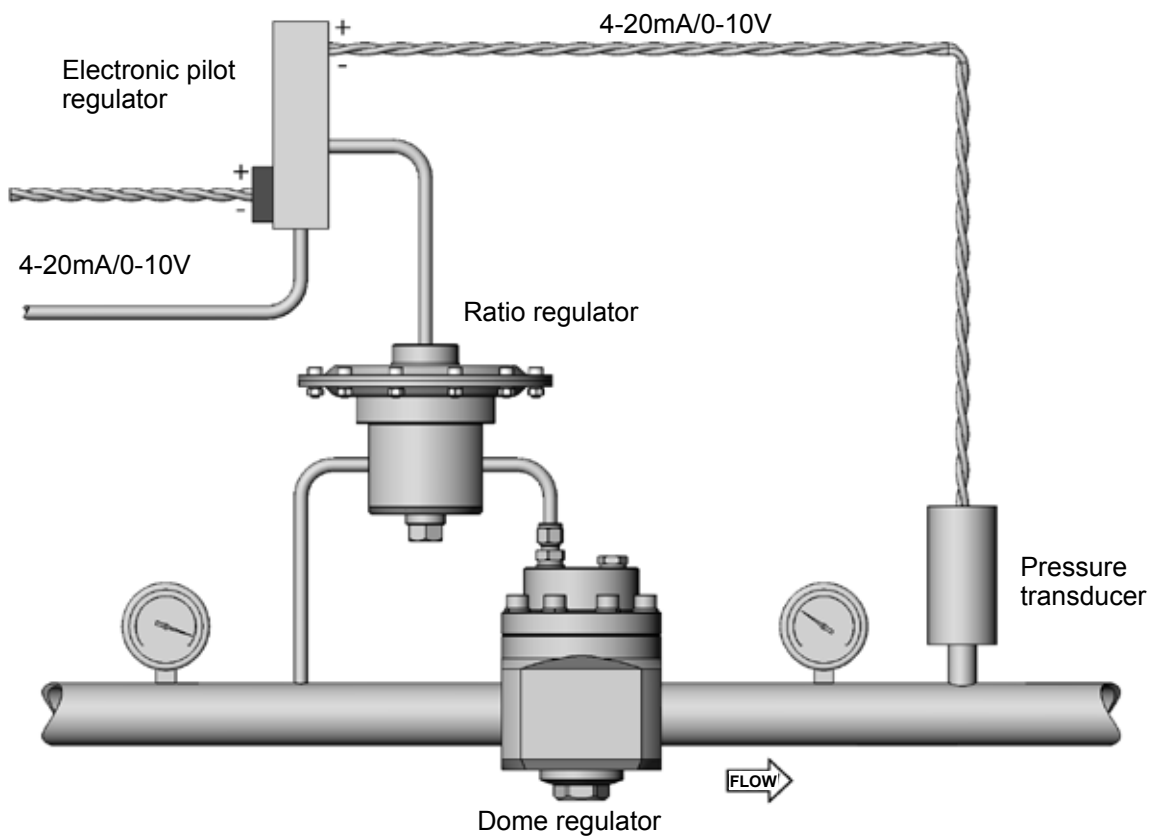

Dome regulator

Fig 5



## External Feedback

The purpose of external feedback is to provide a more accurate and stable regulation of the outlet pressure. This is achieved by sensing the outlet pressure downstream of the regulator and feeding it back to the regulator's sensing element.

- 
- The external feedback line is to be connected in a turbulence-free zone in the downstream piping, at a maximum distance of 5x the outside diameter of the downstream tubing/piping (Fig 6).
- The tube size of the external feedback should be 3/8 in. or 1/2 in. or the metric equivalent.

**CAUTION**  
 When using a regulator with external feedback, ensure that the outlet line is connected to the external feedback port before applying pressure to the regulator. Failing to do so may lead to damage and non-functioning of the regulator and no pressure regulation will occur.

**CAUTION**  
 Never connect the external feedback line downstream of a shut-off valve. Doing so may lead to damage and non-functioning of the regulator and no pressure regulation will occur.

### External Feedback Schematic

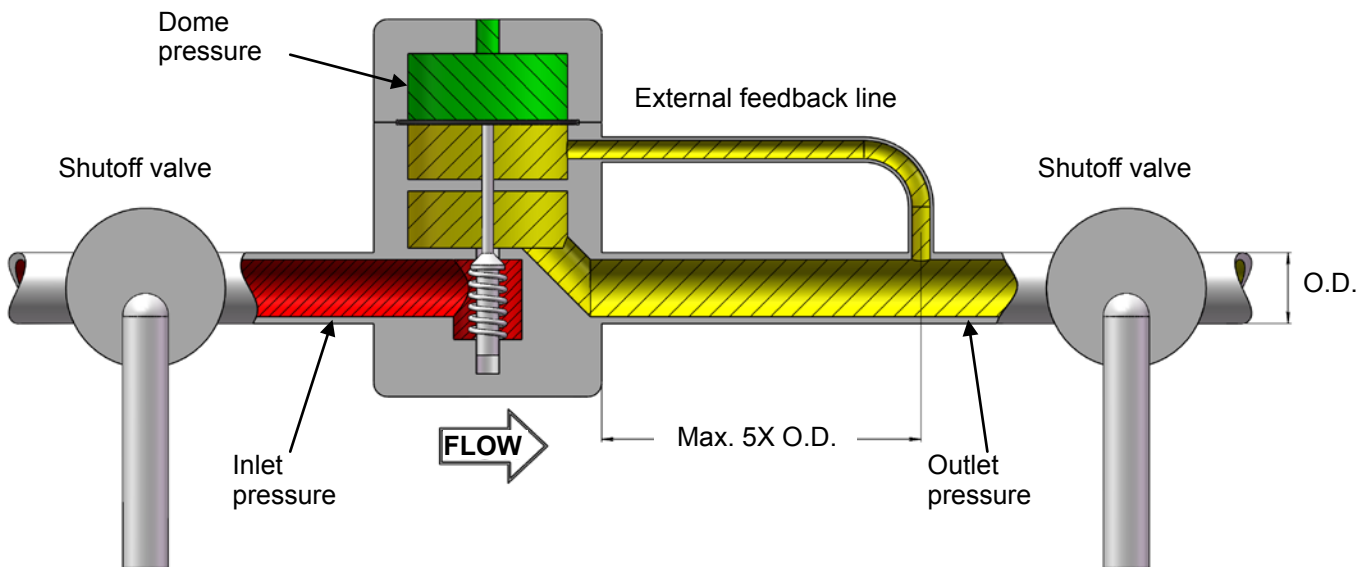

Fig 6

# Operation

## Required Tools for Operation

No tools are required for changing the set pressure on a standard regulator.

## Points of Attention Before Operation



### CAUTION

The product can be hot or cold, depending on the environmental temperature and the process media temperature. Take the necessary precautions before operating or touching the product.

- Stopping flow through the regulator by closing a downstream shutoff valve may result in a rise in outlet pressure above the set pressure. This is usually referred to as “**lock-up**”. This phenomenon does not indicate a problem with the regulator.
- A decrease of the flow rate may result in a rise of the outlet pressure. An increase of the flow rate may result in a fall of the outlet pressure. This is usually referred to as “**droop**”. This phenomenon does not indicate a problem with the regulator.
- A decrease of the inlet pressure may result in a rise of the outlet pressure. An increase of the inlet pressure may result in a fall of the outlet pressure. This is usually referred to as “**inlet dependency**” or “**Supply Pressure Effect (SPE)**”. This phenomenon does not indicate a problem with the regulator.

## Adjusting the Set Pressure

- The set pressure is the desired outlet pressure of the regulator.
  - To set the regulator, ensure that the supply pressure is greater than the required set pressure but does not exceed the maximum rating of the regulator.
  - The regulator must be able to flow in order for it to reduce the outlet pressure.
1. Partially open any downstream valve. This will allow minimal flow through the regulator when adjusting the set pressure, reducing media consumption during this process.
  2. Ensure there is zero pressure in the dome.
  3. Steadily open the supply valve to allow inlet pressure to the regulator.
  4. To operate the regulator, turn the pilot adjustment knob clockwise to increase the set pressure. Turn the knob counterclockwise to reduce the set pressure.
  5. To obtain the most accurate set pressure, final adjustment must be made while **increasing** the set pressure. If the desired outlet pressure is exceeded, reduce the pressure below this value then increase up to it.
  6. Fully open the downstream valve to allow full flow during operation.
  7. Once under flow conditions make any final set pressure adjustments per steps 3 and 4 if required.



### NOTICE

The pilot regulator knob assembly is retained by a C-ring. When backing off the knob do not attempt to continue to unwind the knob once it has stopped. Doing so may damage the C-ring.

## Maintenance







### WARNING

Incorrect or improper repair or servicing of this product can cause serious personal injury and property damage.

- All repairs, servicing and testing of this product must be performed by competent personnel.
- Following any maintenance of the regulator, it is recommended that the product be tested for operation and leakage.
- The product should be checked periodically for proper and safe operation. It is the user's sole responsibility to determine the frequency of maintenance based on the application.
- To reduce maintenance related system downtime to a minimum, either during commissioning or normal operation, Swagelok recommends having maintenance kits readily available on site. The need for maintenance kits is particularly important during the commissioning phase of a system installation due to residual assembly debris remaining in the system. Such debris can cause a seat leak in the regulator, resulting in components needing to be replaced.

### Required Tools for Maintenance

Smooth-jawed vise		Calibrated torque wrench up to 52 lbf·ft (70 N·m)	
46 mm socket		Seat Mounting Tool RHPS-20-SEAT-TOOL RHPS-25-SEAT-TOOL	
Appropriate open-ended wrenches for disassembling tube fittings		Lubricant (included in kit) WL-8 <sup>①</sup> Krytox <sup>®</sup> 240 AC <sup>②</sup>	
10 mm hex drive		Liquid leak detector	
C-ring pliers			

<sup>①</sup> Standard cleaned assemblies

<sup>②</sup> ASTM G93 or SC11 cleaned assemblies

Table 1

## Points of Attention Before Removal from the System

- Swagelok recommends removing the regulator from the system for servicing and maintenance.
- Follow all local system safety and maintenance procedures when removing the regulator.



### **WARNING**

**Before removing a regulator from the system, to avoid personal injury, you must:**

- **Depressurize the system and dome.**
- **Purge the system to remove any residual system media left in the regulator.**
- **Always vent to a safe environment away from people and ensure there is adequate ventilation.**



### **CAUTION**

**Check if the process media is hazardous or toxic. If required, take the necessary safety precautions to ensure a safe workspace and your personal safety.**



### **CAUTION**

**The product can be hot or cold, depending on the environmental temperature and the process media temperature. Take the necessary precautions before operating or touching the product.**

## Removal from the System

1. Isolate the regulator from all pressure sources by closing all appropriate upstream valves in the system.
2. With the pilot regulator set, open all appropriate downstream valves to allow pressure to vent from the regulator.



### **WARNING**

**Ensure all pressure on the inlet, outlet and dome has been fully vented. The accidental release of residual trapped pressure can cause serious personal injury.**

3. Ensure appropriate lifting equipment is available to enable the regulator to be supported and handled once disconnected from the system.
4. Ensure that any external dome feed or external feedback connection is disconnected.
5. Disconnect and remove the regulator from the system.

## Assembly Reference Data

Item	Component Name	Kit Type(s)	Torque lbf·ft (N·m)	Recommended Lubrication (included in kit per Table 1)
1	Body plug	C1, C2	52 (70)	Lubricate threads
2	Body plug O-ring	B1, B2, C1, C2		
3	Poppet spring	C1, C5		
4	Poppet backup ring <sup>Ⓢ</sup>	A1, A2, B1, B2, C1		
5	Poppet guide ring <sup>Ⓢ</sup>	B1, B2, C1, C2		
6	Poppet O-ring	A1, A2 <sup>Ⓢ</sup> , B1, B2, C1, C2 <sup>Ⓢ</sup>		Lubricate
7	Poppet	A1, A2, B1, C1		
8	Seat	A1, B1, C1	RD(H)20 - 15 (20)	Lubricate threads
			RD(H)25 - 18 (25)	
9	Seat O-ring	A1, B1, B2, C1		
10	Body	N/A		
11	Body plate	C1		
12	Body plate outer O-ring	B1, B2, C1		
13	Body plate inner O-ring	B1, B2, C1		Lubricate
14	Retaining ring	C1		
15	Conical spring	C1		
16	Diaphragm plate	C1		
17	Diaphragm	B1, B2, C1, C3		
18	Dome plate	N/A		
19	Dome	N/A		
20	BSP blind plug O-ring	B1, B2, C1		
21	Blind plug	N/A	NPT: 15 (20)	Wrap threads in 2 layers of PTFE tape. Lubricate tape.
			BSP: 26 (35)	Lubricate threads
22	Washer	E1		
23	Cap screw	E1	52 (70)	Lubricate threads
24	Parallel gasket	B1, B2, C1		
25	Bleed fitting (reduced orifice)	N/A	Per manufacturer instructions	
26	Tube fitting	N/A	Per manufacturer instructions	
27	Bleed tube	N/A		
28	Feed tube	N/A		
29	Pilot regulator	N/A		
30	Dome tube	N/A		

<sup>Ⓢ</sup> RD(H)20 series only

<sup>Ⓢ</sup> RD(H)25 series only

Table 2

For more information on RHPS series maintenance kits, refer to the *Pressure Regulators, RHPS Series* catalog, MS-02-430.

RD(H)20, RD(H)25 Series Exploded View

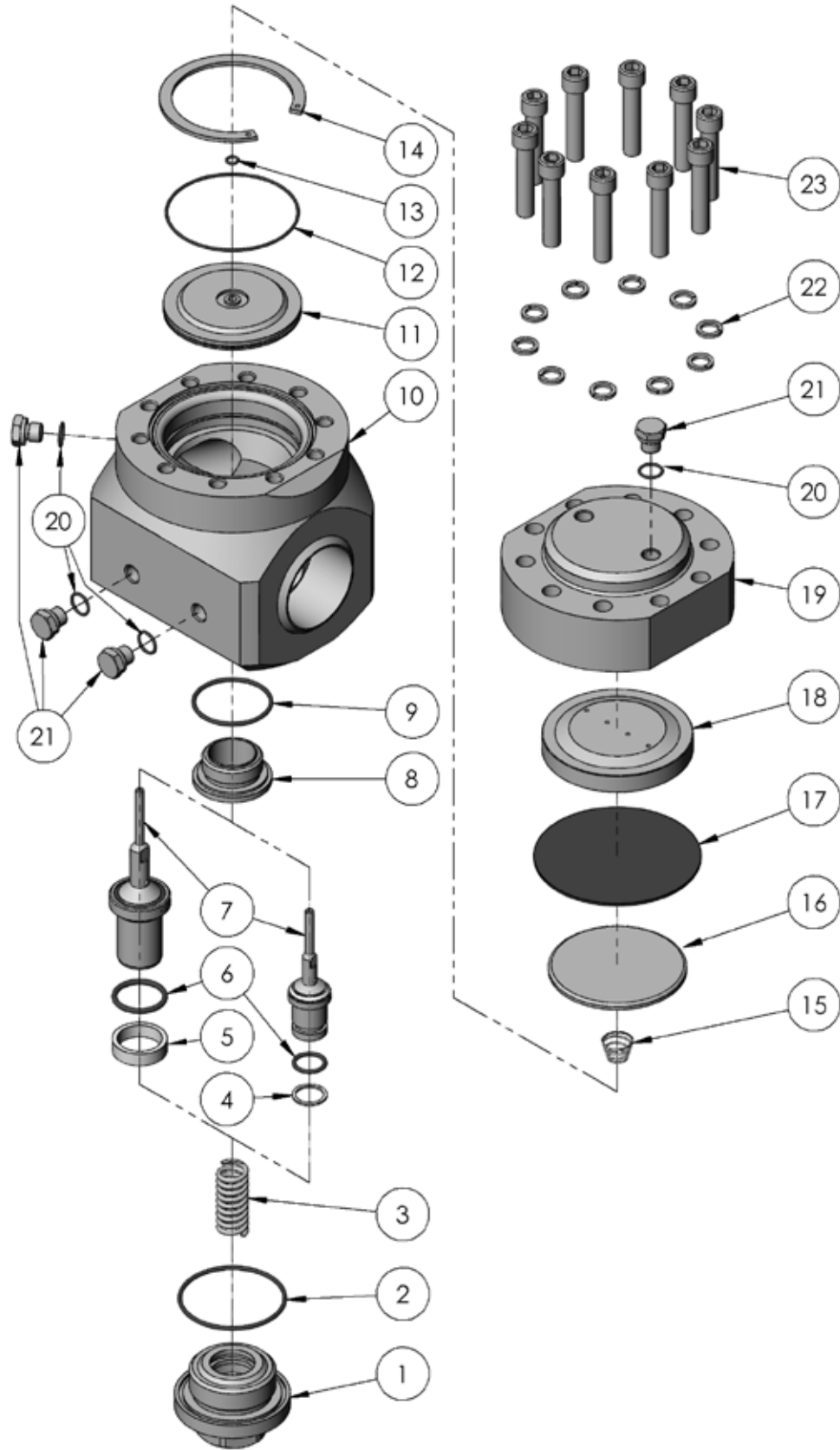

Fig 7

**Integral Pilot Regulator Assembly Exploded View**

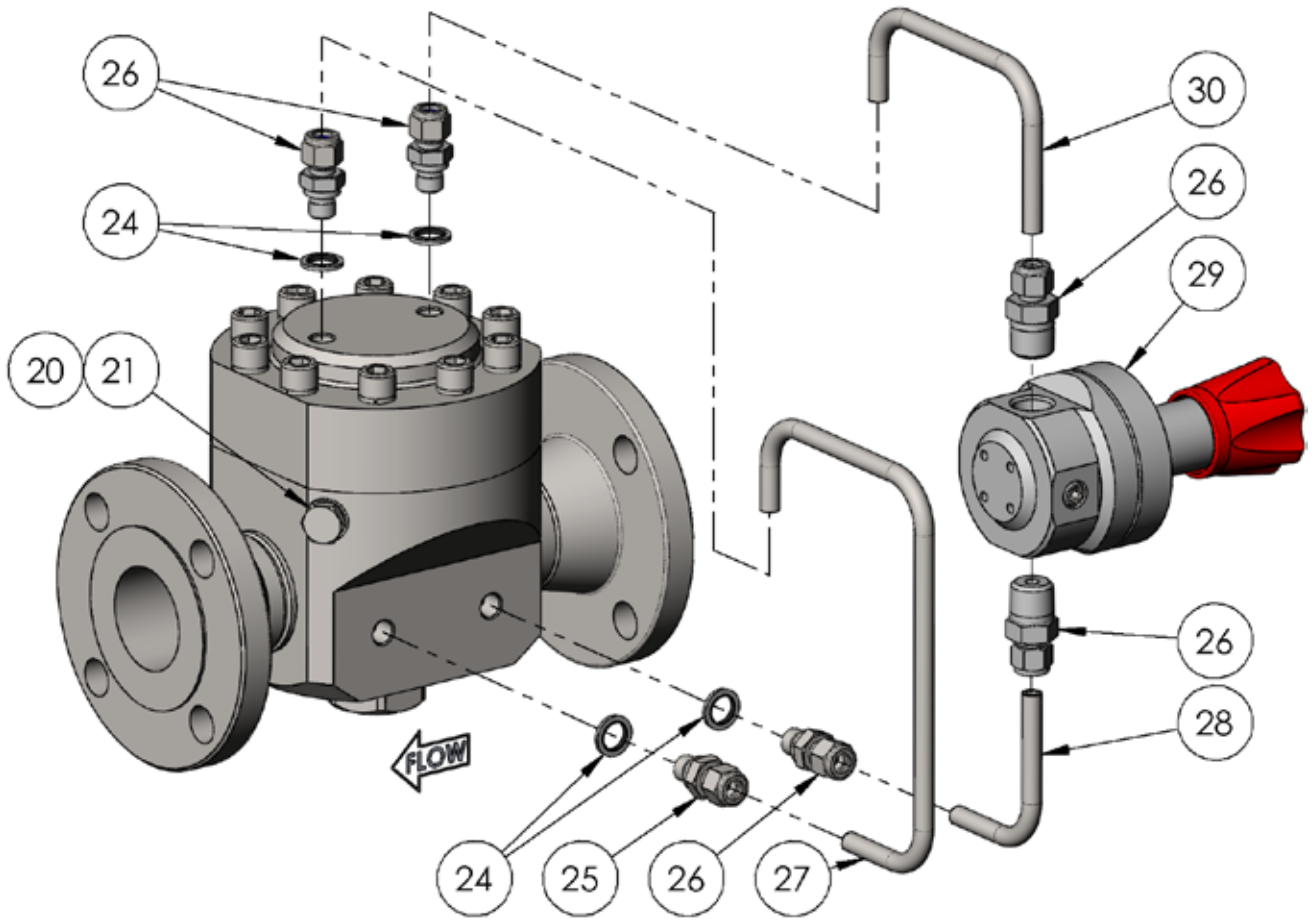

Fig 8

RDH20 Series, Standard, Section View

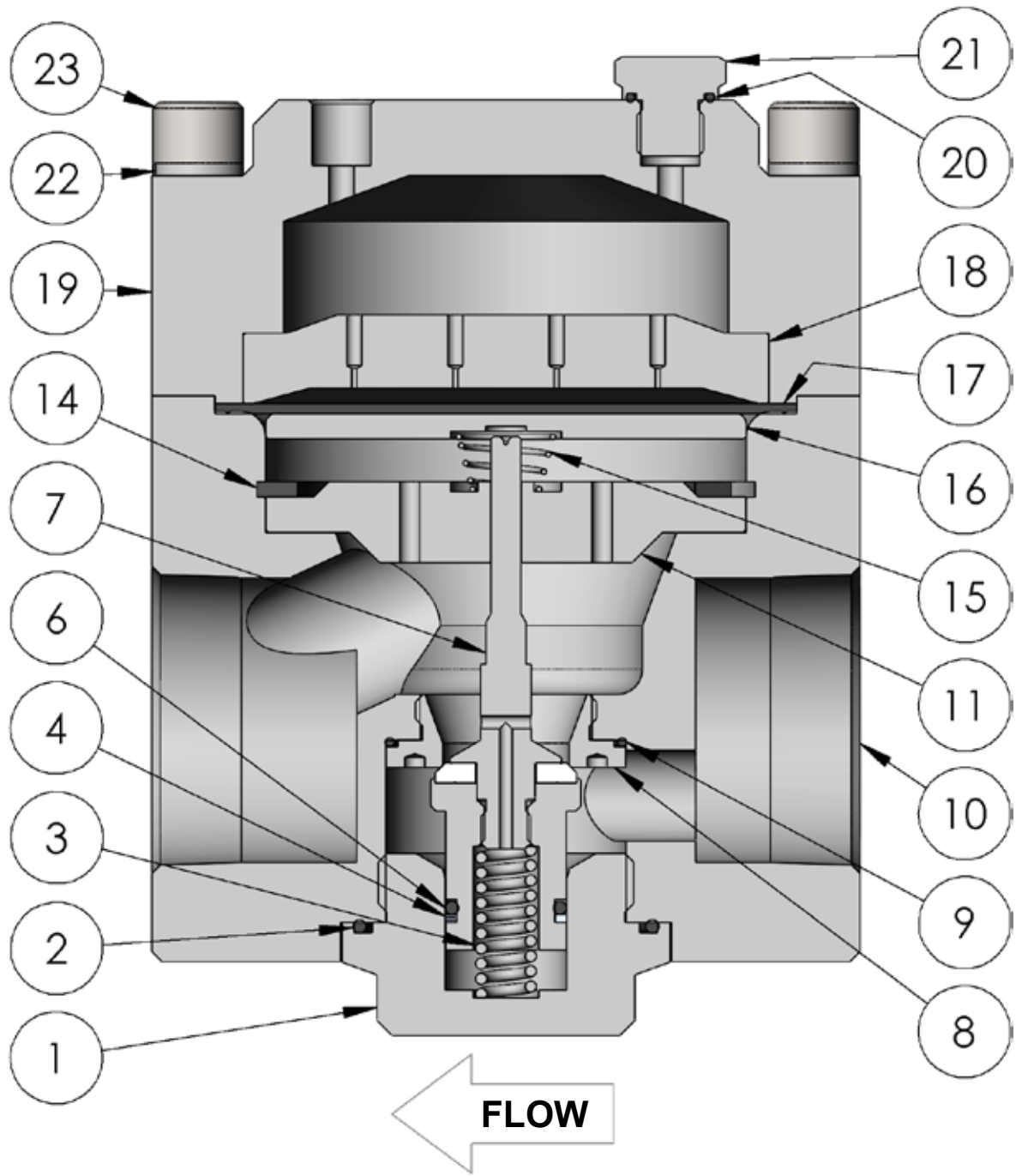

Fig 9



RD25 Series, External Feedback, Section View

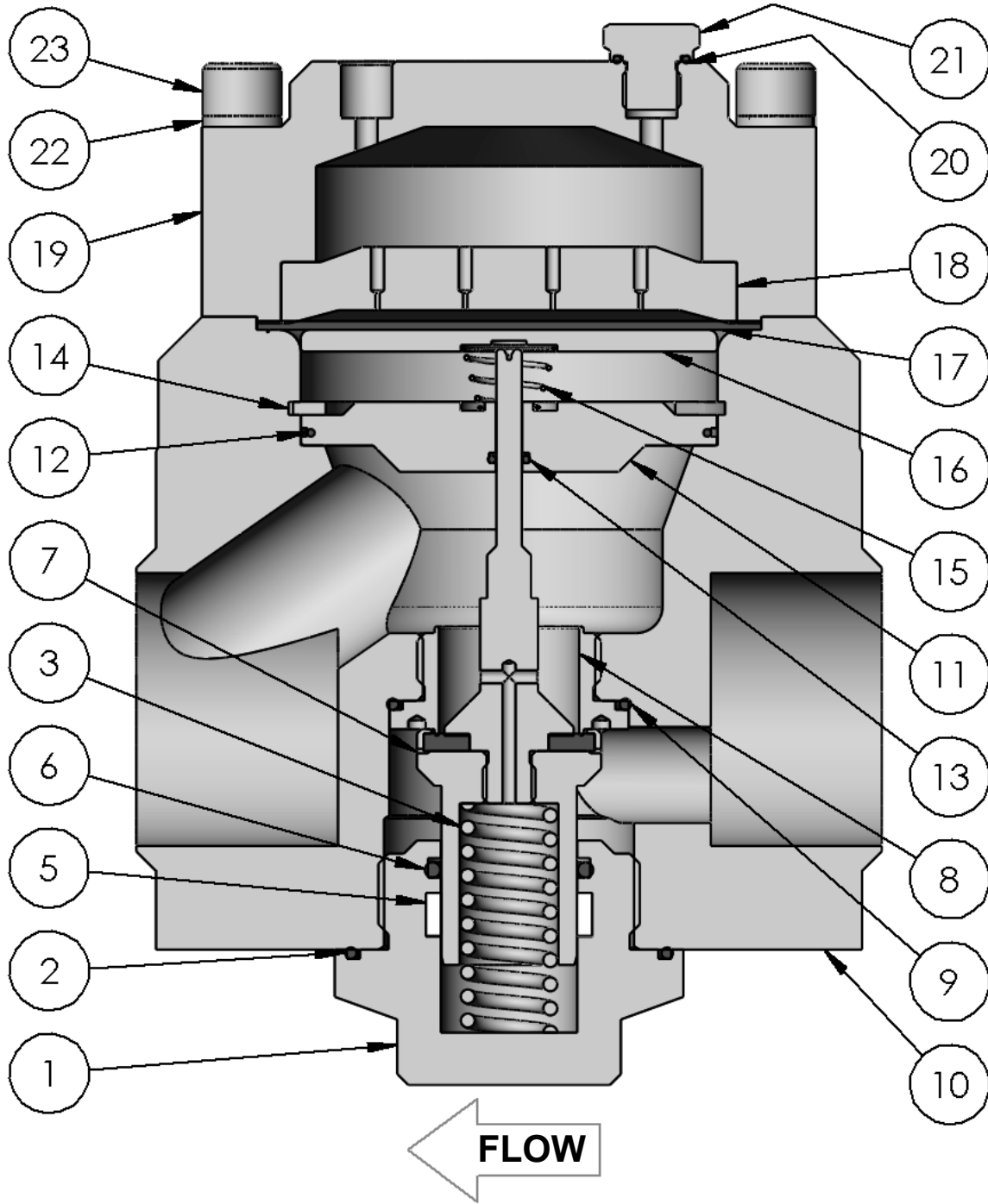

Fig 10

## Disassembly

- The following instructions describe how to fully disassemble the regulator for the purposes of maintenance and repair.
  - Note that not all components listed appear in all regulator configurations.
  - Only disassemble the regulator as far as is required to replace the components supplied in the maintenance kit.
  - Discard all components being replaced.
1. If present remove the feed tube (28), dome tube (30), bleed tube (27), and pilot regulator (29).
  2. Remove the body plug (1), poppet spring (3), and poppet (7) from the body (10).
  3. Remove the body plug O-ring (2), poppet O-ring (6) and, if present, poppet backup ring (4) and guide ring (5) from the body plug (1) and poppet (7).
  4. Using the seat insertion tool, remove the seat (8) and seat O-ring (9).
  5. Remove the cap screws (23) to remove the dome (19), dome plate (18), diaphragm (17), and diaphragm plate (16).
  6. Remove the retaining ring (14) to remove the body plate (11). For external feedback regulators remove the inner (13) and outer (12) body plate O-rings.

## Points of Attention Before Reassembly

- Visually inspect all components for abnormal wear or damage. Replace components in case of doubt.
- All parts must remain clean and undamaged before starting assembly.
- Maintenance kit components will be supplied preassembled where practicable to aid reassembly.
- Swagelok recommends replacing all O-rings removed during disassembly.
- Swagelok recommends that dynamic O-rings should be lightly lubricated per Table 2.



### NOTICE

**All threaded components must be lightly lubricated per Table 2 before reassembly to avoid galling of threads.**

## Reassembly

### RD(H)20 Series: Standard

1. Fit the body plate (11) into the body (10) and retain with the retaining ring (14).
2. Fit the seat O-ring (9) into the body (10) and ensure that it is seated all the way round.
3. Lightly lubricate the seat threads (8) then insert the seat (8) into the body (10) using the seat insertion tool. Torque to 11 lbf·ft (20 N·m). Take care not to pinch the seat O-ring (9) or damage the seat (8) with the tool.
4. Fit the poppet O-ring (6) and, if present, backup ring (4) onto the poppet (7). Ensure they are oriented correctly per Fig 9.
5. Lightly lubricate the poppet O-ring (6) then insert the poppet (7) through the seat (8) and body plate (11). Take care not to damage either the seat (8) or poppet (7).
6. Place the poppet spring (3) into the poppet (7).
7. Fit the body plug O-ring (2) onto the body plug (1) and lightly lubricate the body plug threads.
8. Insert the body plug (1) into the body (10) over the poppet spring (3). Torque to 52 lbf·ft (70 N·m).
9. Place the diaphragm plate (16) onto the poppet (7).
10. Place the diaphragm (17) onto the diaphragm plate (16) and locate it in the body (10).
11. Place the dome plate (18) centrally onto the diaphragm (17) then cover with the dome (19). Orient the dome ports per Fig 8.
12. Lightly lubricate the cap screw threads (23) then use them and the washers (22) to secure the dome (19) to the body (10). Torque to 52 lbf·ft (70 N·m).
13. Install the feed tube (28), dome tube (30) and pilot regulator (29) into the ports on the inlet side of the body (10) per Fig 8.
14. Install the bleed tube (27) into the ports on the outlet side of the body (10) per Fig 8. Note that the bleed fitting (25) can be identified by its reduced internal orifice.
15. Make up all tube fittings (25, 26) per the manufacturers recommendations.

### RD(H)25 Series: Standard

1. Follow steps 1 and 2 of the RD(H)20 series standard reassembly procedure.
2. Lightly lubricate the seat threads (8) then insert the seat (8) into the body (10) using the seat insertion tool. Torque to 18 lbf·ft (25 N·m). Take care not to pinch the seat O-ring (9) or damage the seat (8) with the tool.
3. Fit the poppet O-ring (6) and guide ring (5) into the body plug (1).
4. Follow steps 5 through 15 of the RD(H)20 series standard reassembly procedure.

### RD(H)20 and RD(H)25 Series: External Feedback

1. Fit the inner (13) and outer (12) body plate O-rings onto the body plate (11). Lightly lubricate the inner body plate O-ring (13).
2. For size 20 regulators follow the RD(H)20 series standard reassembly procedure.
3. For size 25 regulators follow the RD(H)25 series standard reassembly procedure.

## Testing

Swagelok recommends that the regulator be tested for seat and shell leakage to atmosphere. A well performing regulator will not show any indication of leaking. If any evidence of a leak is identified this must be rectified. Any damaged components must be replaced.

### Seat Leak Test

1. Ensure there is sufficient supply pressure to the regulator to be able to perform the tests.
2. Ensure that there is zero pressure in the dome.
3. Maintain an inlet pressure of approximately 14.5 psig (1 bar) on the regulator and close the downstream shutoff valve.
4. Monitor the outlet pressure. An increase in pressure over time indicates a seat leak.
5. Repeat the procedure with the highest inlet pressure applicable for the regulator and system.

### Shell Leak Test

1. Maintain an inlet pressure of approximately 29 psig (2 bar) on the regulator and close the downstream shutoff valve.
2. Increase the outlet pressure to approximately 14.5 psig (1 bar).
3. Using liquid leak detector, check for bubbles at the dome to body interface and the body plug to body interface.
4. Repeat the procedure with the highest inlet and outlet pressure applicable for the regulator and system.

## Troubleshooting

Symptom	Cause	Remedy
The outlet pressure creeps up, without adjusting dome pressure.	A damaged poppet or seat.	Replace the poppet and/or seat.
Leakage around the body plug.	A damaged O-ring.	Replace the O-ring.
Leakage between the body and the dome.	A damaged diaphragm.	Replace the diaphragm.
	Insufficient torque on the cap screws.	Tighten the cap screws per Table 2.
Controlled pressure drops off sharply even when the flow is within regulator capabilities.	The system filter element is clogged.	Replace the system filter.
The required outlet pressure cannot be reached.	The inlet pressure to the regulator is not high enough.	Ensure that the inlet pressure to the regulator is equal to or greater than the desired set pressure.
The outlet pressure rises too much when going from a dynamic to a static situation.	There is too much flow in the dynamic situation.	A larger regulator or parallel regulator is required. Review application flow capacity and contact your local authorized sales and service center.
The outlet pressure does not drop when the pressure in the dome is lowered.	The regulator is non-venting.	A shutoff valve in the outlet line must be opened to reduce the outlet pressure.
The outlet pressure has changed without adjusting the dome pressure.	Changes to the inlet pressure may result in changes to the outlet pressure.	Maintain a constant inlet pressure to the regulator. See “ <b>Points of Attention Before Operation</b> ” about <b>dependency</b> .
	Changes to the flow may result in changes to the outlet pressure.	Maintain a constant flow through the regulator. See “ <b>Points of Attention Before Operation</b> ” about <b>droop</b> .
No pressure regulation occurs with an external feedback regulator.	The outlet line has not been connected to the external feedback port.	Connect the outlet line to the external feedback port. See “External Feedback” for installation details.

Table 3





## Warranty Information

Swagelok products are backed by The Swagelok Limited Lifetime Warranty.  
For a copy, visit [swagelok.com](http://swagelok.com) or contact your authorized Swagelok representative.

Swagelok, Snoop - TM Swagelok Company

Krytox – TM The Chemours Company

© 2018-2019 Swagelok Company

September 2019, RevD

MS-CRD-0182

The Swagelok logo is written in a blue, cursive-style font.