

Hose and Flexible Tubing



Hose Assemblies, Bulk Hose, Flexible Tubing, and End Connections

- Core materials include metal, PTFE, PFA, vinyl, nylon, polyethylene, and rubber
- Nominal hose sizes 1/8 to 2 in.
- Wide range of fractional and metric end connections
- Custom lengths available
- Optional covers, tagging, and testing

Contents

Swagelok® Hose and Flexible Tubing Nomenclature, 4

Swagelok Hose and Flexible Tubing Selection Guide, 6

Considerations for Selecting a Hose Assembly Solution, 8

Swagelok Hose and Flexible Tubing Installation and Use Guide, 9

Metal Hose

FM Series Metal Hose, 10



FJ Series Metal Hose, 16



FL Series Metal Hose, 21



Metal Flexible Tubing

CT Series Convoluted Metal Tubing, 25



Fluoropolymer Hose

T Series PTFE Hose, 30



B Series PTFE Hose, 36



X Series PTFE Hose, 38



S Series PTFE Hose, 40



C Series PTFE Hose, 42



N Series PTFE Hose, 44



Contents

W Series PTFE Hose, 46



F Series PTFE Hose, 48



U Series PFA Hose, 50



PFA Tubing

PFA Series PFA Tubing, 61



Vinyl Tubing

LT Series Vinyl Tubing, 63



Hose Connectors

HC Series—End Connections for Soft Tubing and Hose, 64

Nylon Hose

NG Series Nylon Hose, 67



7R and 8R Series Nylon Hose, 71



7N and 8N Series Nylon Hose, 72



Polyethylene Hose

7P Series Polyethylene Hose, 77



Rubber Hose

PB Series Rubber Hose, 79



Options

Covers, 83



Testing, 83

Tags, 84



Approvals, 84

Tools and Accessories

Cutting Tools for Hose and Soft Tubing, 85



Assembly Tools for Nylon, Polyethylene, and Rubber Hose, 86

Accessories for Hand and Power Swagers, 86

Pushers and Swage Dies for Nylon and Polyethylene Hose, 87



Dimensions, in inches (millimeters), are for reference only and are subject to change. Dimensions are shown with Swagelok nuts finger-tight. For Swagelok nut dimensions, see the Swagelok *Gaugeable Tube Fittings and Adapter Fittings* catalog, MS-01-140.

Swagelok Hose and Flexible Tubing Nomenclature

Hose

A multiple-layered flexible conduit through which fluid is conveyed from one point to another.

Nominal Hose Size

An approximation of the hose inside diameter.

Flexible Tubing

A single-layered flexible conduit through which fluid is conveyed from one point to another.

Bend Radius

The radius of the bent section of hose, measured to the center line or inside of the curved section.

Minimum Dynamic Bend Radius

The smallest bend radius that a hose is rated to perform in a dynamic application.

Minimum Static Bend Radius

The smallest bend radius that a hose is rated to perform in a static application.

Flexibility

The relative ease or difficulty of bending a nonpressurized hose or tubing assembly.

Burst Pressure

The pressure at which leakage occurs when exposed to a laboratory burst test.

Splices

Splices consist of a connector fitting and crimp collars that join two lengths of hose to form assemblies. Splices may be required to obtain longer hose lengths of fluoropolymer hose (B, X, S, C, N, W, F, and U series), as noted in the **Ordering Information** for each series.

Splice dimensions shown in the table at right are for reference only and are subject to change. Additional overall hose length may be needed to compensate for the effect of splices on hose minimum bend radius. For more information, contact your authorized Swagelok sales and service representative.

Static Dissipation

The ability of a material to conduct an electrical charge to ground. Select Swagelok hoses are constructed with carbon black-filled nylon, PTFE, or PFA core material for static dissipation. For quick reference in this catalog, these hoses are indicated with the omega symbol (Ω) in the hose description.

Conductivity

The ability of a material to transmit or conduct an electrical charge. Swagelok hoses constructed with a metallic braid layer have the potential to be conductive hoses. For quick reference in this catalog, these hoses are indicated with the symbol (M) in the hose description.

Permeation

The movement of a liquid, gas, or vapor through a solid. All materials are permeable to a degree and should be tested for application compatibility prior to installation.

Dynamic Application

An application in which the hose flexes or changes position.

Static Application

An application in which the hose is stationary and does not move in any plane.

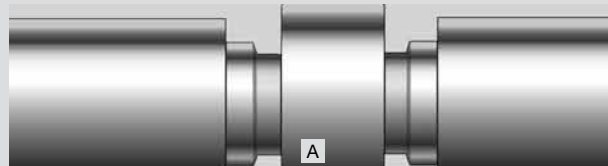
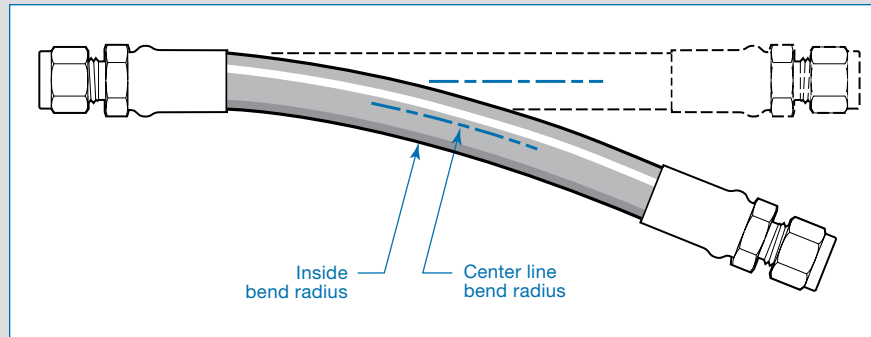

Nominal Hose Size in. (mm)	Dimensions, in. (mm)		
	A Maximum	Minimum Inside Diameter	Maximum Outside Dimension
1/8 (3.2)	2.60 (66.0)	0.070 (1.7)	0.55 (14.0)
1/4 (6.4)	2.60 (66.0)	0.16 (4.0)	0.59 (15.0)
3/8 (9.6)	3.30 (83.8)	0.26 (6.6)	0.82 (20.8)
1/2 (12.7)	3.70 (94.0)	0.34 (8.6)	1.04 (26.4)
3/4 (19.0)	4.80 (122)	0.54 (13.7)	1.35 (34.3)
1 (25.4)	4.60 (117)	0.78 (19.8)	1.75 (44.4)
1 1/2 (38.1)	5.60 (142)	1.24 (31.4)	2.20 (55.9)
2 (50.8)	6.90 (175)	1.68 (42.6)	2.74 (69.6)

Swagelok Hose and Flexible Tubing Nomenclature

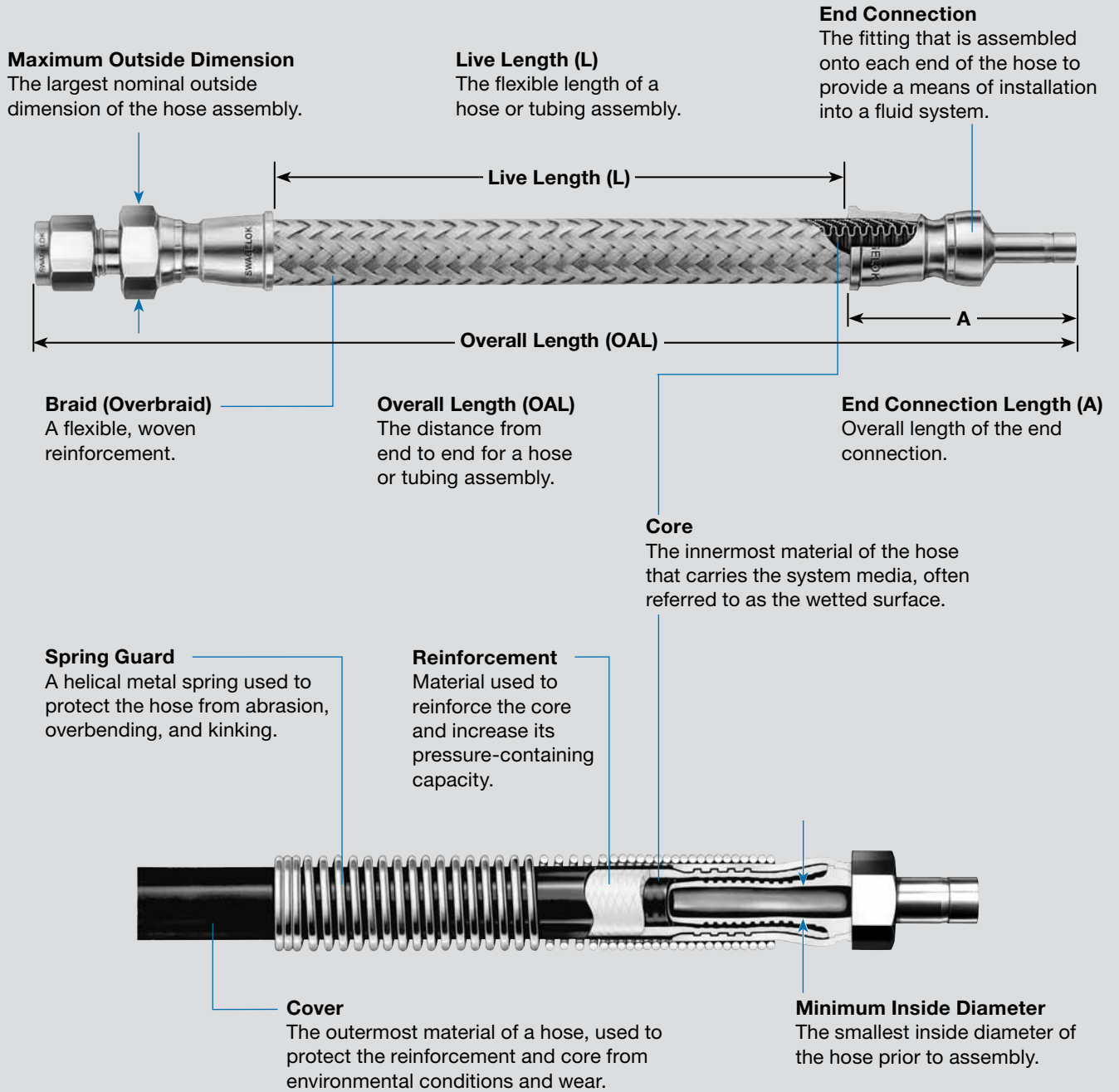

Swagelok Hose and Flexible Tubing Selection Guide

See individual hose series sections for additional technical information.

Series	Materials of Construction			Page
	Core	Reinforcement	Cover	
Metal Hose				
FM	Convolute 316L SS	316L SS braid	—	10
FJ	Convolute 316L SS	304 SS braid standard; 316L SS braid available	—	16
FL	Convolute 316L SS	321 SS braid	—	21
Metal Flexible Tubing				
CT	Convolute 321 SS	—	—	25
Fluoropolymer Hose				
T	Smooth-bore PTFE ^①	304 SS braid standard; 316L SS and alloy 400 braid available	—	30
B	Smooth-bore PTFE	304 SS braid	—	36
X	Smooth-bore PTFE ^①	Fiber braid with 304 SS braid	—	38
S	Smooth-bore PTFE ^①	Fiber braid with 304 SS braid	Silicone	40
C	Convolute PTFE ^①	300 series SS braid	No cover standard; silicone cover available	42
N	Convolute, carbon black-filled PTFE	Insulating wrap and aramid fiber braid	—	44
W	Smooth-bore, carbon black-filled PTFE	Fiber braid with insulating wrap and 304 SS braid	Silicone	46
F	Smooth-bore PTFE ^①	Fiber braid	—	48
U	Smooth-bore PFA ^②	302 SS braid	Silicone	50
PFA Tubing				
PFA	Smooth-bore PFA	—	—	61
Vinyl Tubing				
LT	Smooth-bore clear vinyl	—	—	63
Nylon Hose				
NG	Smooth-bore, static dissipative nylon	Fiber braid	Perforated black polyurethane with blue stripe	67
7R	Smooth-bore nylon	Fiber braid	Perforated black polyurethane	71
8R	Smooth-bore nylon	Fiber braid	Perforated black polyurethane	71
7N	Smooth-bore, nonconductive nylon	Fiber braid	Nonperforated orange polyurethane	72
8N	Smooth-bore, nonconductive nylon	Fiber braid	Nonperforated orange polyurethane	72
Polyethylene Hose				
7P	Smooth-bore polyethylene	Fiber braid	Nonperforated blue polyurethane	77
Rubber Hose				
PB	Smooth-bore Buna N	Synthetic fiber braid	Blue Buna N (other colors available)	79

^① Carbon black-filled PTFE core is available for applications that require static dissipation.

^② Carbon black-filled PFA core is available for applications that require static dissipation.

Swagelok Hose and Flexible Tubing Selection Guide

See individual hose series sections for additional technical information.

Series	Nominal Hose Size, in.										Temperature Range °F (°C)	Page
	Working Pressure at 70°F (20°C), psig (bar)											
	1/8	3/16	1/4	3/8	1/2	3/4	1	1 1/4	1 1/2	2		
Metal Hose												
FM	—	—	3100 (213)	2000 (137)	1800 (124)	1500 (103)	1200 (82.6)	950 (65.4)	900 (62.0)	500 (34.4)	–325 to 850 (–200 to 454)	10
FJ	—	—	1600 (110)	1470 (101)	1110 (76.4)	860 (59.2)	680 (46.8)	680 (46.8)	520 (35.8)	450 (31.0)	–325 to 800 (–200 to 426)	16
FL	—	—	1500 (103)	—	1200 (82.6)	—	—	—	—	—	–325 to 850 (–200 to 454)	21
Metal Flexible Tubing												
CT	—	—	100 (6.8)	25 (1.7)	25 (1.7)	25 (1.7)	25 (1.7)	—	25 (1.7)	—	70 to 1000 (20 to 537)	25
Fluoropolymer Hose												
T	—	—	3000 ^① (206)	2500 (172)	2000 (137)	1500 (103)	1000 (68.9)	—	—	—	–65 to 450 ^② (–53 to 230)	30
B	3000 (206)	—	—	—	—	—	—	—	—	—		36
X	—	—	3500 (241)	3000 (206)	1800 (124)	1250 (86.1)	1000 (68.9)	—	—	—		38
S	3000 (206)	—	3500 (241)	3000 (206)	1800 (124)	1250 (86.1)	1000 (68.9)	—	—	—		40
C	—	—	—	—	1500 (103)	1100 (75.7)	750 (51.6)	—	700 (48.2)	525 (36.1)		42
N	—	—	—	1250 (86.1)	750 (51.6)	375 (25.8)	—	—	—	—		44
W	—	—	—	750 (51.6)	750 (51.6)	500 (34.4)	—	—	—	—		46
F	—	—	800 (55.1)	650 (44.7)	450 (31.0)	325 (22.3)	—	—	—	—		48
U	—	—	—	—	300 (20.6)	300 (20.6)	250 (17.2)	—	200 (13.7)	150 (10.3)	–65 to 400 (–53 to 204)	50
PFA Tubing												
PFA	275 (18.9)	—	275 (18.9)	180 (12.4)	125 (8.6)	83 (5.7)	61 (4.2)	—	—	—	70 to 400 (20 to 204)	61
Vinyl Tubing												
LT	40 (2.7)	30 (2.0)	25 (1.7)	15 (1.0)	10 (0.68)	—	—	—	—	—	–40 to 165 (–40 to 73)	63
Nylon Hose												
NG	—	—	5000 (344)	5000 (344)	—	—	—	—	—	—	–40 to 150 (–40 to 65)	67
7R	—	—	2750 (189)	2250 (155)	2000 (137)	—	—	—	—	—	–40 to 200 (–40 to 93)	71
8R	—	—	5000 (344)	4000 (275)	3500 (241)	2250 (155)	2000 (137)	—	—	—	–40 to 200 (–40 to 93)	71
7N	—	—	2750 (189)	2250 (155)	2000 (137)	—	—	—	—	—	–40 to 200 (–40 to 93)	72
8N	—	—	—	—	—	2250 (155)	—	—	—	—	–40 to 200 (–40 to 93)	72
Polyethylene Hose												
7P	—	—	2750 (189)	2250 (155)	2000 (137)	1500 (103)	1500 (103)	—	—	—	–10 to 150 (–23 to 65)	77
Rubber Hose												
PB	—	—	350 (24.1)	300 (20.6)	300 (20.6)	300 (20.6)	300 (20.6)	—	—	—	–40 to 200 ^③ (–40 to 93)	79

① T series hose with alloy 400 braid is rated to 1500 psig (103 bar).

② C series hose is rated from –20 to 340°F (–28 to 171°C) in the 1 1/2 and 2 in. nominal hose sizes.

③ PB series hose is rated from –20 to 200°F (–28 to 93°C) in the 1 in. nominal hose size.

Considerations for Selecting a Hose Assembly Solution

Temperature

Identify the minimum and maximum temperatures the hose assembly will be exposed to with regard to the system media and the environment.

Pressure

Identify the minimum and maximum pressures (or vacuum) within and outside the hose assembly.

Material

Identify the system media and the environment to which the hose assembly will be exposed. This will help determine the materials of construction best suited to the application demands and whether the hose requires a static dissipative core.

Movement

Confirm whether the hose assembly will be installed in dynamic applications as this will require different considerations than a static application.

Length

Determine the most likely route for installation of the hose, and use this to identify length requirements.



Cleanliness

Identify the need for cleanliness. Ease of cleaning the internal surfaces of the hose, as well as maintaining outside cleanliness may be of concern.

End Connection

Identify the type of end connections which are most compatible with the system requirements. End connections differ with regard to materials of construction and pressure ratings.

Orientation

Clarify space constraint concerns. Hose assemblies with elbows and union ball joints may help resolve space constraint issues.

Desired Flow

Consider desired flow. Hose connection size, core tube construction, and routed installation may impact flow.

Drainability

Consider core construction as this will impact drainability.

Test Reports

Identify the need for documentation in the form of test reports.

Special Testing

Many applications may require testing to requirements different from the production tests listed. For example, metal hose assemblies undergo an inboard helium leak test to a maximum leak rate of 1×10^{-5} std cm³/s. If your application uses liquid at a positive pressure, you may request an additional hydrostatic proof test.

Special Marking

Discuss special marking requirements; there are different options available to readily identify hose assemblies.

Documentation and Regulatory Requirements

Identify the need for special regulatory approvals or documentation.

Additional Protection and Covers

Identify whether covers are necessary for additional protection of the hose assemblies or surrounding systems.

Additional Considerations

- Use of hose and tubing within applications and handling practices will affect how it performs over time. Catalog performance claims such as burst pressure, working pressure, static dissipation, moisture content, permeation rates, and cycle life apply to never-used products. For this reason, system maintenance and replacement schedules should be considered.

Cautions

- ⚠ **Nylon, PFA, polyethylene, PTFE, and rubber are permeable materials. Gases, vapors, and liquids may migrate through cores of these materials. The rate of permeation is affected by many application-specific variables.**
- ⚠ **Nonperforated covers may blister in gas service.**
- ⚠ **Thermal cycling of any nonmetal hose may affect its ability to maintain a positive seal. Testing should be performed to verify suitability in actual operating conditions.**
- ⚠ **All equipment must be properly grounded to allow static dissipation and help to prevent static sparking.**
- ⚠ **Nonconductive hoses can be conduits for electricity if they contain conductive fluids. Verify the conductive properties of the system media prior to use.**

Swagelok Hose and Flexible Tubing Installation and Use Guide

Inspection

Establish an inspection schedule based on system application and replacement history.

Electrostatic Discharge

Static electricity can be generated by fluid passing through the hose. Select hose with sufficient conductivity to ground the static electric charge and allow static dissipation. If static electricity generation is possible within an application, choose static dissipative hose and properly ground to earth.

Vibration

Evaluate amount of system vibration when selecting hose. Metal hose may not be appropriate for systems with constant or severe vibration.

Length

Take into consideration hose movement, system pressurization, and thermal expansion when determining hose length. Installing hose that does not have sufficient length to accommodate these factors may reduce hose life.

Minimum Bend Radius

Follow minimum bend radius requirements for your hose. Installing hose with smaller bends may kink hose and reduce hose life.

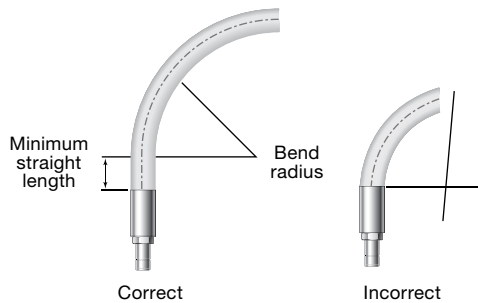

Hose rupture or leakage may result from bending too close to the hose/fitting connection.

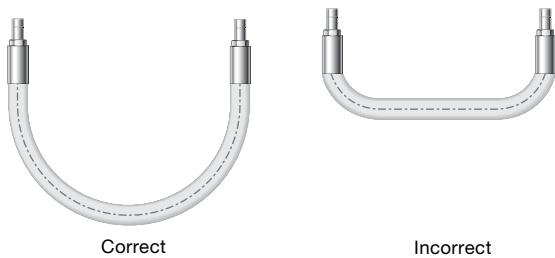

Hose Strain

Elbows and adapters can be used to relieve hose strain.

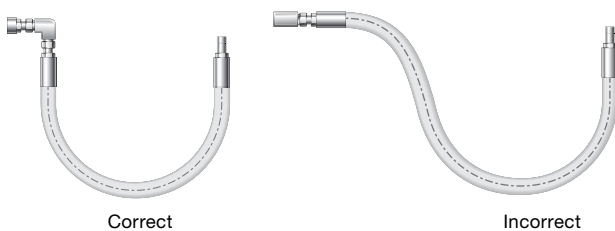

Motion Absorption

Distribute movement and prevent bends smaller than the hose's minimum bend radius by providing sufficient hose length.

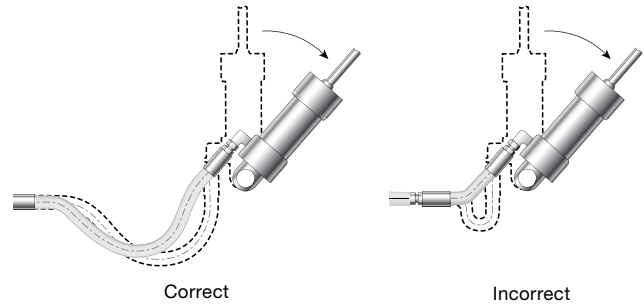

Machine Tolerance

Allow for changes in length resulting from machine motion and tolerances.

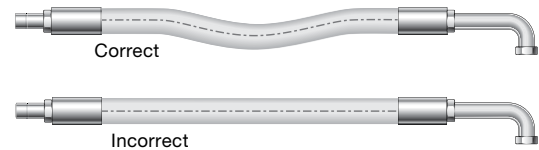

System Pressure Changes

Allow sufficient hose length to accommodate changing system pressures. Do not connect high- and low pressure hoses.

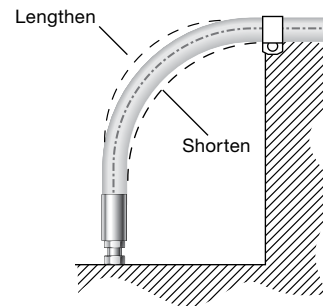

Bending in One Plane

Avoid twisting the hose by bending it in one plane only. For a compound bend, use multiple hose pieces or other isolation methods.

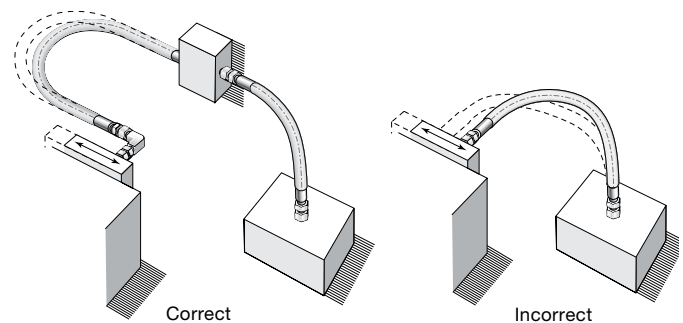

For additional information, see SAE J1273, *Recommended Practices for Hydraulic Hose Assemblies*.

Images on this page reprinted with permission from SAE J1273. © 2009 SAE International.

FM Series Metal Hose

Features

- All-metal hose promotes corrosion resistance.
- 316L stainless steel annular convoluted core.
- Size range of 1/4 through 2 in. and working pressures from vacuum to 3100 psig (213 bar).
- Single braid layer of 316L stainless steel promotes hose pressure containment and exhibits strong performance in dynamic cycling applications (M).
- End connections welded in accordance with ASME Boiler and Pressure Vessel Code Section IX.
- Commonly used in high-temperature vacuum applications and medium-pressure corrosive environments, or where permeation is undesirable.
- Standard and custom assemblies available.
- Options include hose covers, hose tags, and additional helium leak testing. See page 83 for details.

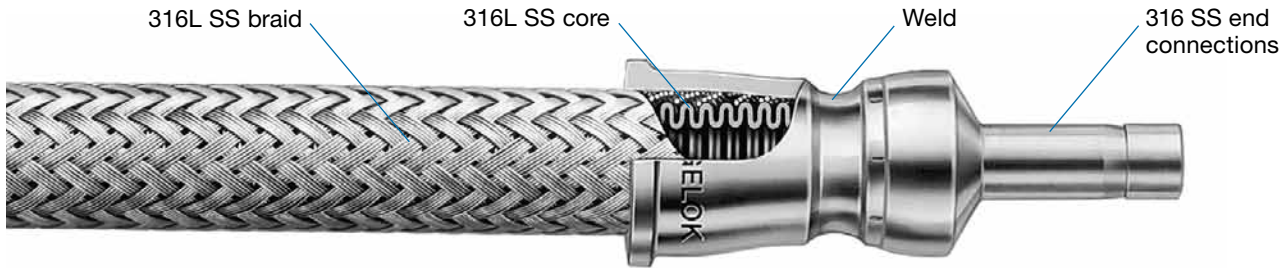

Technical Data

Nominal Hose Size in. (mm)	Inside Diameter in. (mm)	Outside Diameter in. (mm)	Minimum Center Line Bend Radius in. (cm)		Temperature Range °F (°C)	Working Pressure at -325 to 100°F (-200 to 37°C) Vacuum to ... psig (bar)	Burst Pressure at 70°F (20°C) psig (bar)	Bulk Hose Weight lb/ft (kg/m)
			Static	Dynamic				
1/4 (6.4)	0.28 (7.1)	0.53 (13.5)	2.25 (5.72)	10.0 (25.4)	-325 to 850 (-200 to 454)	3100 (213)	12 400 (854)	0.33 (0.49)
3/8 (9.7)	0.42 (10.6)	0.69 (17.5)	3.00 (7.62)	12.0 (30.5)		2000 (137)	8 000 (551)	0.29 (0.43)
1/2 (12.7)	0.53 (13.5)	0.85 (21.6)	4.50 (11.4)	16.0 (40.6)		1800 (124)	7 200 (496)	0.45 (0.67)
3/4 (19.0)	0.80 (20.3)	1.15 (29.1)	6.00 (15.2)	17.0 (43.2)		1500 (103)	6 000 (413)	0.62 (0.92)
1 (25.4)	1.03 (26.0)	1.45 (36.9)	6.75 (17.1)	20.0 (50.8)		1200 (82.6)	4 800 (330)	0.77 (1.15)
1 1/4 (31.8)	1.30 (33.0)	1.75 (44.5)	4.50 (11.4)	23.0 (58.4)		950 (65.4)	3 800 (261)	1.05 (1.56)
1 1/2 (38.1)	1.53 (38.9)	2.02 (51.3)	5.25 (13.3)	26.0 (66.0)		900 (62.0)	3 600 (248)	1.18 (1.76)
2 (50.8)	2.05 (52.1)	2.57 (65.3)	6.75 (17.1)	32.0 (81.3)		500 (34.4)	2 000 (137)	1.66 (2.47)

Pressure-Temperature Ratings

Ratings are based on ASME Code for Pressure Piping, B31.1 Power Piping, and ASME Boiler and Pressure Vessel Code.

Nominal Hose Size, in.	1/4	3/8	1/2	3/4	1	1 1/4	1 1/2	2
Temperature, °F (°C)	Working Pressure, vacuum to ... psig (bar)							
-325 (-200) to 100 (37)	3100 (213)	2000 (137)	1800 (124)	1500 (103)	1200 (82.6)	950 (65.4)	900 (62.0)	500 (34.4)
200 (93)	2604 (179)	1680 (115)	1512 (104)	1260 (86.8)	1008 (69.4)	798 (54.9)	756 (52.0)	420 (28.9)
300 (148)	2356 (162)	1520 (104)	1368 (94.2)	1140 (78.5)	912 (62.8)	722 (49.7)	684 (47.1)	380 (26.1)
400 (204)	2170 (149)	1400 (96.4)	1260 (86.8)	1050 (72.3)	840 (57.8)	665 (45.8)	630 (43.4)	350 (24.1)
500 (260)	2015 (138)	1300 (89.5)	1170 (80.6)	975 (67.1)	780 (53.7)	618 (42.5)	585 (40.3)	325 (22.3)
600 (315)	1922 (132)	1240 (85.4)	1116 (76.8)	930 (64.0)	744 (51.2)	589 (40.5)	558 (38.4)	310 (21.3)
700 (371)	1829 (126)	1180 (81.3)	1062 (73.1)	885 (60.9)	708 (47.8)	561 (38.6)	531 (36.5)	295 (20.3)
800 (426)	1767 (121)	1140 (78.5)	1026 (70.6)	855 (58.9)	684 (47.1)	542 (37.3)	513 (35.3)	285 (19.6)
850 (454)	1736 (119)	1120 (77.1)	1008 (69.4)	840 (57.8)	672 (46.3)	532 (36.6)	504 (34.7)	280 (19.2)

FM Series Metal Hose

Testing

Every Swagelok FM series hose assembly is inboard helium leak tested to a maximum leak rate of 1×10^{-5} std cm³/s.

For additional testing, see **Testing**, page 83.

Cleaning and Packaging

Swagelok FM series hose components are cleaned in accordance with Swagelok *Standard Cleaning and Packaging (SC-10)*, MS-06-62. Each hose is bagged individually and boxed; longer hoses are coiled, bagged, and boxed.

⚠ Do not subject flexible metal hose to pressure surges, shock, or pulsations, where the peak pressure is greater than 50 % of the working pressure rating.

METAL

Ordering Information and Dimensions

Standard Length Hose Assemblies

Select an ordering number.

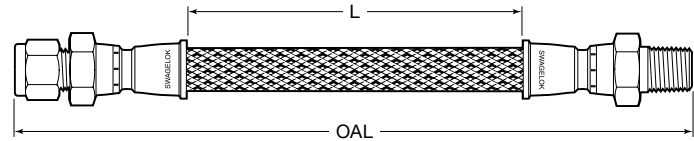

Swagelok Tube Fitting to Male NPT End Connection



Nominal Hose Size in.	Tube Fitting Size in.	NPT Size in.	Overall Length OAL in. (cm)	Ordering Number	Dimensions		
					Live Length L in. (cm)	Minimum Inside Diameter in. (mm)	Maximum Outside Dimension in. (mm)
1/4	1/4	1/4	12.0 (30.5)	SS-FM4SL4PM4-12	8.26 (21.0)	0.19 (4.8)	0.95 (24.1)
			36.0 (91.4)	SS-FM4SL4PM4-36	32.3 (82.0)		
3/8	3/8	3/8	18.0 (45.7)	SS-FM6SL6PM6-18	14.2 (36.1)	0.28 (7.1)	1.09 (27.7)
			36.0 (91.4)	SS-FM6SL6PM6-36	32.2 (81.8)		
1/2	1/2	1/2	18.0 (45.7)	SS-FM8SL8PM8-18	13.6 (34.5)	0.41 (10.4)	1.23 (31.3)
			48.0 (122)	SS-FM8SL8PM8-48	43.6 (111)		
3/4	3/4	3/4	18.0 (45.7)	SS-FM12SL12PM12-18	13.4 (34.0)	0.66 (16.0)	1.74 (44.2)
			48.0 (122)	SS-FM12SL12PM12-48	43.4 (110)		
1	1	1	24.0 (61.0)	SS-FM16SL16PM16-24	18.8 (47.8)	0.88 (22.4)	2.03 (51.6)
			60.0 (152)	SS-FM16SL16PM16-60	54.8 (139)		

Swagelok Tube Fitting End Connections



Nominal Hose Size in.	Tube Fitting Size in.	Overall Length OAL in. (cm)	Ordering Number	Dimensions		
				Live Length L in. (cm)	Minimum Inside Diameter in. (mm)	Maximum Outside Dimension in. (mm)
1/4	1/4	12.0 (30.5)	SS-FM4SL4SL4-12	8.12 (20.6)	0.19 (4.8)	0.95 (24.1)
		36.0 (91.4)	SS-FM4SL4SL4-36	32.1 (81.5)		
3/8	3/8	18.0 (45.7)	SS-FM6SL6SL6-18	14.0 (35.6)	0.28 (7.1)	1.09 (27.7)
		36.0 (91.4)	SS-FM6SL6SL6-36	32.0 (81.3)		
1/2	1/2	18.0 (45.7)	SS-FM8SL8SL8-18	13.5 (34.3)	0.41 (10.4)	1.23 (31.3)
		48.0 (122)	SS-FM8SL8SL8-48	43.5 (110)		
3/4	3/4	18.0 (45.7)	SS-FM12SL12SL12-18	13.3 (33.8)	0.66 (16.0)	1.74 (44.2)
		48.0 (122)	SS-FM12SL12SL12-48	43.3 (110)		
1	1	24.0 (61.0)	SS-FM16SL16SL16-24	18.7 (47.5)	0.88 (22.4)	2.03 (51.6)
		60.0 (152)	SS-FM16SL16SL16-60	54.7 (139)		

See next page for more hose assemblies.

FM Series Metal Hose

End Connections

Swagelok Tube Adapters

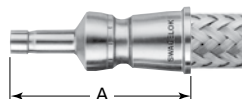

Tube Adapter Size	Nominal Hose Size Designator	End Connection Designator	Dimensions		
			A	Minimum Inside Diameter	Maximum Outside Dimension
Dimensions, in. (mm)					
1/4	4	TA4	1.76 (44.7)	0.16 (4.1)	0.75 (19.0)
3/8	6	TA6	1.82 (46.2)	0.27 (6.9)	0.93 (23.6)
1/2	8	TA8	2.22 (56.4)	0.37 (9.4)	1.05 (26.7)
3/4	12	TA12	2.35 (59.7)	0.58 (14.7)	1.38 (35.1)
1	16	TA16	2.69 (68.3)	0.80 (20.3)	1.69 (42.9)
Dimensions, mm (in.)					
6	4	TM6	44.4 (1.75)	4.1 (0.16)	19.0 (0.75)
10	6	TM10	47.0 (1.85)	7.1 (0.28)	23.5 (0.93)
12	8	TM12	57.2 (2.25)	8.9 (0.35)	26.7 (1.05)

Swagelok Tube Fittings



Cap Weld Style—
1 in. and Under



Manual Weld Style—
Over 1 in.

Tube Fitting Size	Nominal Hose Size Designator	End Connection Designator	Dimensions		
			A	Minimum Inside Diameter	Maximum Outside Dimension
Dimensions, in. (mm)					
1/4	4	SL4	1.94 (49.3)	0.19 (4.8)	0.95 (24.1)
3/8	4	SL6	2.00 (50.8)	0.28 (7.1)	0.95 (24.1)
	6	SL6	2.02 (51.3)		1.09 (27.7)
1/2	8	SL8	2.24 (56.9)	0.41 (10.4)	1.23 (31.3)
5/8	8	SL10	2.27 (57.7)	0.50 (12.7)	0.95 (24.1)
3/4	12	SL12	2.35 (59.7)	0.63 (16.0)	1.74 (44.2)
1	16	SL16	2.64 (67.1)	0.88 (22.4)	2.03 (51.6)
1 1/4 ^①	20	SL20	4.04 (103)	1.09 (27.7)	2.23 (58.9)
1 1/2 ^①	24	SL24	4.75 (121)	1.34 (34.0)	2.61 (66.3)
2 ^①	32	SL32	5.72 (145)	1.88 (47.8)	3.48 (88.4)
Dimensions, mm (in.)					
6	4	SM6	30.2 (1.19)	4.8 (0.19)	20.6 (0.81)
8	4	SM8	50.3 (1.98)	6.4 (0.25)	20.6 (0.81)
10	6	SM10	51.6 (2.03)	7.9 (0.31)	27.9 (1.10)
12	8	SM12	59.7 (2.35)	9.7 (0.38)	31.3 (1.23)

① Furnished with silver-plated front ferrule and uncoated back ferrule which are required for performance above 450°F (232°C).

Rotatable Male VCR® Metal Gasket Face Seal Fittings

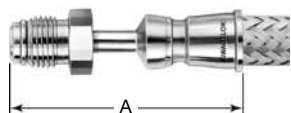

VCR Size in.	Nominal Hose Size Designator	End Connection Designator	Dimensions, in. (mm)		
			A	Minimum Inside Diameter	Maximum Outside Dimension
1/4	4	RM4	2.60 (66.0)	0.18 (4.6)	0.73 (18.4)
1/2	8	RM8	2.83 (71.9)	0.40 (10.2)	1.09 (27.7)
3/4	12	RM12	4.19 (106)	0.65 (16.5)	1.52 (38.7)
1	16	RM16	4.80 (122)	0.87 (22.1)	1.89 (47.9)

See next page for more end connections.

FM Series Metal Hose

METAL

Rotatable Female VCR Metal Gasket Face Seal Fittings

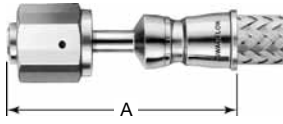

VCR Size in.	Nominal Hose Size Designator	End Connection Designator	Dimensions, in. (mm)		
			A	Minimum Inside Diameter	Maximum Outside Dimension
1/4	4	RF4	2.00 (50.8)	0.18 (4.6)	0.87 (22.1)
1/2	8	RF8	2.16 (54.9)	0.40 (10.2)	1.23 (31.3)
3/4	12	RF12	4.15 (105)	0.65 (16.5)	1.74 (44.2)
1	16	RF16	4.76 (121)	0.87 (22.1)	2.03 (51.6)

Female VCO® O-Ring Face Seal Fittings

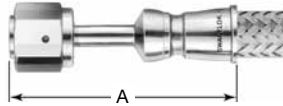

VCO Size in.	Nominal Hose Size Designator	End Connection Designator	Dimensions, in. (mm)		
			A	Minimum Inside Diameter	Maximum Outside Dimension
1/4	4	VF4	2.00 (50.8)	0.18 (4.6)	0.80 (20.3)
1/2	8	VF8	2.14 (54.4)	0.40 (10.2)	1.16 (29.5)

SAE 37° (JIC) Female Swivel

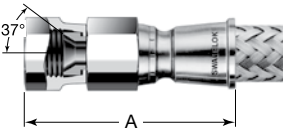

Swivel Size in.	Nominal Hose Size Designator	End Connection Designator	Dimensions, in. (mm)		
			A	Minimum Inside Diameter	Maximum Outside Dimension
1/4	4	AS4	1.87 (47.5)	0.17 (4.3)	0.94 (23.9)
3/8	6	AS6	1.97 (50.0)	0.28 (7.1)	1.09 (27.7)
1/2	8	AS8	2.15 (54.6)	0.42 (10.7)	1.23 (31.3)

Female Pipe Threads, NPT



NPT Size in.	Nominal Hose Size Designator	End Connection Designator	Dimensions, in. (mm)		
			A	Minimum Inside Diameter	Maximum Outside Dimension
1/4	4	PF4	1.81 (46.0)	0.28 (7.1)	0.94 (23.9)
3/8	6	PF6	1.87 (47.5)	0.38 (9.7)	1.09 (27.7)
1/2	8	PF8	2.18 (55.4)	0.47 (11.9)	1.23 (31.3)
3/4	12	PF12	2.21 (56.1)	0.72 (18.3)	1.74 (44.2)

FM Series Metal Hose

Male Pipe Threads,
NPT and ISO/BSP Tapered
(ISO 7)

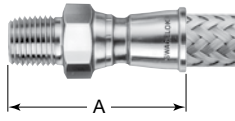

Cap Weld Style—
1 in. and Under

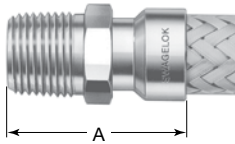

Manual Weld Style—
Over 1 in.

NPT and ISO/BSP Tapered Size in.	Nominal Hose Size Designator	End Connection Designator	Dimensions, in. (mm)		
			A	Minimum Inside Diameter	Maximum Outside Dimension
NPT					
1/4	4	PM4	1.80 (45.7)	0.28 (7.1)	0.94 (23.9)
	6	PM4	1.81 (46.0)	0.28 (7.1)	1.09 (27.7)
3/8	6	PM6	1.81 (46.0)	0.38 (9.7)	1.09 (27.7)
1/2	4	PM8	1.99 (50.6)	0.47 (11.9)	1.02 (25.8)
	8	PM8	2.15 (54.6)	0.47 (11.9)	1.23 (31.3)
3/4	12	PM12	2.22 (56.4)	0.63 (16.0)	1.74 (44.2)
1	16	PM16	2.54 (64.5)	0.88 (22.4)	2.03 (51.6)
1 1/4	20	PM20	2.06 (52.3)	1.09 (27.7)	2.03 (51.6)
1 1/2	24	PM24	2.47 (62.7)	1.34 (34.0)	2.47 (62.6)
2	32	PM32	2.92 (74.2)	1.81 (46.0)	3.19 (81.0)
ISO/BSP Tapered					
1/4	4	MT4	1.80 (45.7)	0.28 (7.1)	0.94 (23.9)
1/2	8	MT8	2.16 (54.9)	0.47 (11.9)	1.23 (31.3)

Tube Butt Welds

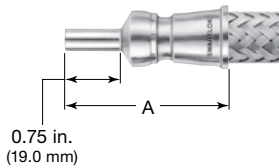

Tube Butt Weld Size in.	Wall Thickness in.	Nominal Hose Size Designator	End Connection Designator	Dimensions, in. (mm)		
				A	Minimum Inside Diameter	Maximum Outside Dimension
1/4	0.035	4	TB4	1.90 (48.3)	0.18 (4.6)	0.75 (19.0)
3/8	0.035	6	TB6	1.89 (48.0)	0.37 (9.4)	0.93 (23.6)
1/2	0.049	8	TB8	2.04 (51.8)	0.50 (12.7)	1.05 (26.7)
3/4	0.049	12	TB12	2.12 (53.8)	0.65 (16.5)	1.38 (35.1)
1	0.065	16	TB16	2.23 (56.6)	0.87 (22.1)	1.69 (42.9)

FJ Series Metal Hose

Features

- General purpose all-metal hose.
- 316L stainless steel annular convoluted core.
- Size range of 1/4 through 2 in. and working pressures from vacuum to 1600 psig (110 bar).
- Single braid layer of 304 stainless steel promotes hose pressure containment (M).
- End connections welded in accordance with ASME Boiler and Pressure Vessel Code Section IX.
- Optional 316L stainless steel braid available to provide greater corrosion resistance.
- Commonly used in high-temperature vacuum or general purpose applications where permeation is undesirable.
- Custom assemblies available.
- Options include hose covers, hose tags, and additional helium leak testing. See page 83 for details.

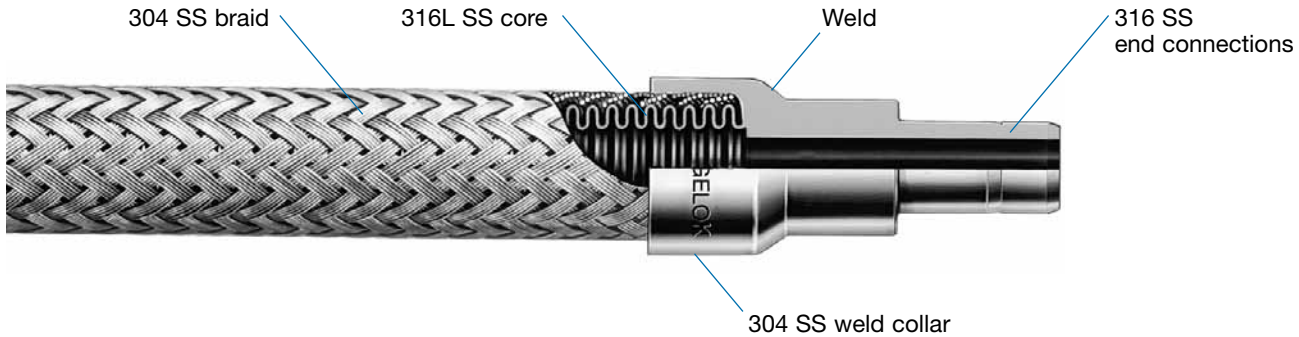

Technical Data

Nominal Hose Size in. (mm)	Inside Diameter in. (mm)	Outside Diameter in. (mm)	Minimum Center Line Bend Radius in. (cm)		Temperature Range °F (°C)	Working Pressure at -325 to 300°F (-200 to 148°C) Vacuum to ... psig (bar)	Burst Pressure at 70°F (20°C) psig (bar)	Bulk Hose Weight lb/ft (kg/m)
			Static	Dynamic				
1/4 (6.4)	0.25 (6.4)	0.47 (11.9)	1.00 (2.54)	4.33 (11.0)	-325 to 800 (-200 to 426)	1600 (110)	6400 (440)	0.11 (0.16)
3/8 (9.7)	0.38 (9.5)	0.68 (17.3)	1.20 (3.05)	5.91 (15.0)		1470 (101)	5880 (405)	0.20 (0.30)
1/2 (12.7)	0.50 (12.7)	0.81 (20.5)	1.50 (3.81)	6.50 (16.5)		1110 (76.4)	4500 (310)	0.22 (0.33)
3/4 (19.0)	0.75 (19.0)	1.20 (30.5)	2.10 (5.33)	8.86 (22.5)		860 (59.2)	3440 (237)	0.37 (0.55)
1 (25.4)	1.00 (25.4)	1.50 (38.0)	2.70 (6.86)	10.2 (25.9)		680 (46.8)	2720 (187)	0.50 (0.74)
1 1/4 (31.8)	1.25 (31.8)	1.80 (45.7)	3.10 (7.87)	11.8 (30.0)		680 (46.8)	2720 (187)	0.61 (0.91)
1 1/2 (38.1)	1.50 (38.1)	2.13 (54.0)	3.90 (9.91)	13.4 (34.0)		520 (35.8)	2080 (143)	0.85 (1.26)
2 (50.8)	2.00 (50.8)	2.66 (67.5)	5.10 (13.0)	15.4 (39.1)		450 (31.0)	1800 (124)	1.10 (1.65)

Pressure-Temperature Ratings

Ratings are based on ASME Code for Pressure Piping B31.3, Process Piping.

Nominal Hose Size, in.	1/4	3/8	1/2	3/4	1	1 1/4	1 1/2	2
Temperature °F (°C)	Working Pressure, vacuum to ... psig (bar)							
-325 (-200) to 300 (148)	1600 (110)	1470 (101)	1110 (76.4)	860 (59.2)	680 (46.8)	680 (46.8)	520 (35.8)	450 (31.0)
400 (204)	1488 (102)	1367 (94.1)	1032 (71.1)	800 (55.1)	632 (43.5)	632 (43.5)	484 (33.3)	419 (28.8)
500 (260)	1376 (94.8)	1264 (87.1)	955 (65.7)	740 (50.9)	585 (40.2)	585 (40.2)	447 (30.8)	387 (26.6)
600 (315)	1296 (89.2)	1191 (82.0)	899 (61.9)	697 (47.9)	551 (37.9)	551 (37.9)	421 (29.0)	365 (25.1)
700 (371)	1232 (84.8)	1132 (77.9)	855 (58.8)	662 (45.6)	524 (36.0)	524 (36.0)	400 (27.5)	347 (23.8)
750 (398)	1200 (82.6)	1103 (75.9)	833 (57.3)	645 (44.4)	510 (35.1)	510 (35.1)	390 (26.8)	338 (23.2)
800 (426)	1184 (81.5)	1088 (74.9)	821 (56.5)	636 (43.8)	503 (34.6)	503 (34.6)	385 (26.5)	333 (22.9)

FJ Series Metal Hose

End Connections

Swagelok Tube Adapters

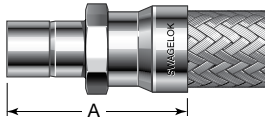
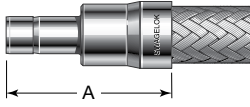

End Connections with Hex Flat

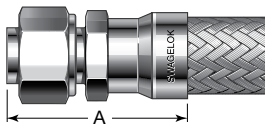

Preswaged Nuts and Ferrules—Over 1 in. / 25 mm

Tube Adapter Size	Nominal Hose Size Designator	End Connection Designator	Dimensions		
			A	Minimum Inside Diameter	Maximum Outside Dimension
Dimensions, in. (mm)					
1/4	4	TA4	1.52 (38.6)	0.18 (4.6)	0.54 (13.7)
3/8	6	TA6	1.81 (46.0)	0.27 (6.9)	0.78 (19.8)
1/2	8	TA8	2.16 (54.9)	0.37 (9.4)	0.93 (23.6)
3/4	12	TA12	2.50 (63.5)	0.58 (14.7)	1.32 (33.5)
1	16	TA16	2.99 (75.9)	0.80 (20.3)	1.63 (41.4)
1 1/4 ^①	20	TA20	3.91 (99.3)	1.02 (25.9)	2.18 (55.2)
1 1/2 ^①	24	TA24	4.47 (114)	1.25 (31.8)	2.61 (66.3)
2 ^①	32	TA32	5.45 (138)	1.72 (43.7)	3.48 (88.4)
Dimensions, mm (in.)					
6	4	TM6	39.0 (1.54)	4.1 (0.16)	13.7 (0.54)
8	4	TM8	39.2 (1.54)	5.6 (0.22)	13.7 (0.54)
10	6	TM10	53.3 (2.10)	7.1 (0.28)	19.8 (0.78)
12	8	TM12	64.8 (2.55)	8.9 (0.35)	25.5 (1.00)
18	12	TM18	61.0 (2.40)	14.0 (0.55)	33.5 (1.32)
25	16	TM25	75.9 (2.99)	19.8 (0.78)	41.4 (1.63)
32 ^①	20	TM32	87.4 (3.44)	26.4 (1.04)	58.0 (2.28)
38 ^①	24	TM38	97.3 (3.83)	31.8 (1.25)	69.6 (2.74)

① Furnished with nut, preswaged silver-plated front ferrule, and uncoated back ferrule which are required for performance above 450°F (232°C).

Swagelok Tube Fittings

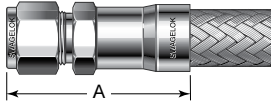

Tube Fitting Size	Nominal Hose Size Designator	End Connection Designator	Dimensions		
			A	Minimum Inside Diameter	Maximum Outside Dimension
Dimensions, in. (mm)					
1/4	4	SL4	1.87 (47.5)	0.19 (4.8)	0.65 (16.6)
3/8	6	SL6	2.07 (52.6)	0.28 (7.1)	0.80 (20.3)
1/2	8	SL8	2.43 (61.7)	0.41 (10.4)	1.02 (25.8)
3/4	12	SL12	2.62 (66.6)	0.63 (16.0)	1.32 (33.5)
1	16	SL16	3.20 (81.3)	0.88 (22.4)	1.63 (41.4)
1 1/4 ^①	20	SL20	3.79 (96.3)	1.09 (27.7)	2.03 (51.6)
1 1/2 ^①	24	SL24	4.25 (108)	1.35 (34.3)	2.47 (65.6)
2 ^①	32	SL32	5.22 (133)	1.82 (46.2)	3.19 (81.0)
Dimensions, mm (in.)					
6	4	SM6	47.5 (1.87)	4.8 (0.19)	16.2 (0.64)
8	4	SM8	48.3 (1.90)	6.4 (0.25)	17.4 (0.69)
10	6	SM10	53.3 (2.10)	7.9 (0.31)	20.9 (0.82)
12	8	SM12	61.7 (2.43)	9.7 (0.38)	25.5 (1.00)
18	12	SM18	66.5 (2.62)	15.0 (0.59)	31.3 (1.23)
25	16	SM25	81.3 (3.20)	21.8 (0.86)	40.5 (1.60)
32 ^①	20	SM32	97.8 (3.85)	28.7 (1.13)	53.4 (2.10)
38 ^①	24	SM38	111 (4.36)	33.8 (1.33)	63.8 (2.51)

① Furnished with silver-plated front ferrule and uncoated back ferrule which are required for performance above 450°F (232°C).

FJ Series Metal Hose

Rotatable Male VCR Metal Gasket Face Seal Fittings

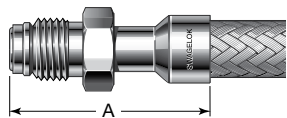

VCR Size in.	Nominal Hose Size Designator	End Connection Designator	Dimensions, in. (mm)		
			A	Minimum Inside Diameter	Maximum Outside Dimension
1/4	4	RM4	1.69 (42.9)	0.18 (4.6)	0.73 (18.4)
1/2	8	RM8	2.00 (50.8)	0.40 (10.2)	1.09 (27.6)
3/4	12	RM12	2.63 (66.8)	0.63 (16.0)	1.52 (38.7)
1	16	RM16	2.97 (75.4)	0.88 (22.4)	1.89 (47.9)

Rotatable Female VCR Metal Gasket Face Seal Fittings

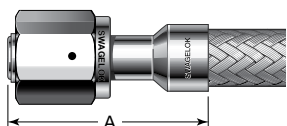

VCR Size in.	Nominal Hose Size Designator	End Connection Designator	Dimensions, in. (mm)		
			A	Minimum Inside Diameter	Maximum Outside Dimension
1/4	4	RF4	1.69 (42.9)	0.18 (4.6)	0.87 (22.1)
1/2	8	RF8	2.00 (50.8)	0.40 (10.2)	1.23 (31.3)
3/4	12	RF12	2.63 (66.8)	0.63 (16.0)	1.74 (44.2)
1	16	RF16	2.97 (75.4)	0.88 (22.4)	2.03 (51.6)

Female VCO O-Ring Face Seal Fittings

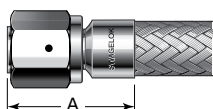

VCO Size in.	Nominal Hose Size Designator	End Connection Designator	Dimensions, in. (mm)		
			A	Minimum Inside Diameter	Maximum Outside Dimension
1/4	4	VF4	1.15 (29.2)	0.19 (4.8)	0.80 (20.3)
1/2	8	VF8	1.31 (33.3)	0.41 (10.4)	1.16 (29.5)
3/4	12	VF12	1.57 (39.9)	0.63 (16.0)	1.74 (44.2)
1	16	VF16	1.73 (43.9)	0.88 (22.4)	2.03 (51.6)

SAE 37° (JIC) Female Swivel

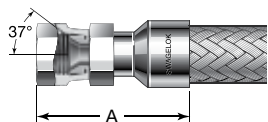

Swivel Size in.	Nominal Hose Size Designator	End Connection Designator	Dimensions, in. (mm)		
			A	Minimum Inside Diameter	Maximum Outside Dimension
1/4	4	AS4	1.55 (39.4)	0.19 (4.8)	0.65 (16.6)
3/8	6	AS6	1.79 (45.5)	0.28 (7.1)	0.80 (20.3)
1/2	8	AS8	1.95 (49.5)	0.39 (9.9)	1.02 (25.8)
3/4	12	AS12	2.27 (57.7)	0.61 (15.5)	1.45 (36.8)
1	16	AS16	2.64 (67.1)	0.84 (21.3)	1.74 (44.2)

Female Pipe Threads, NPT

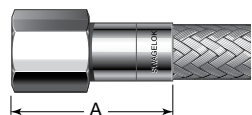

NPT Size in.	Nominal Hose Size Designator	End Connection Designator	Dimensions, in. (mm)		
			A	Minimum Inside Diameter	Maximum Outside Dimension
1/4	4	PF4	1.60 (46.0)	0.30 (7.6)	0.87 (22.1)
3/8	6	PF6	1.84 (46.7)	0.42 (10.7)	1.02 (25.8)
1/2	8	PF8	2.45 (62.2)	0.58 (14.7)	1.23 (31.3)
3/4	12	PF12	2.41 (61.2)	0.73 (18.5)	1.52 (38.7)
1	16	PF16	2.92 (74.2)	0.95 (24.1)	1.89 (47.9)
1 1/2	24	PF24	3.28 (83.3)	1.50 (38.1)	2.76 (70.0)

See next page for more end connections.

FJ Series Metal Hose

Male Pipe Threads, NPT and ISO/BSP Tapered (ISO 7)

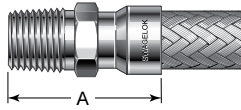

NPT and ISO/BSP Tapered Size in.	Nominal Hose Size Designator	End Connection Designator	Dimensions, in. (mm)		
			A	Minimum Inside Diameter	Maximum Outside Dimension
NPT					
1/4	4	PM4	1.70 (43.2)	0.28 (7.1)	0.65 (16.6)
3/8	6	PM6	1.91 (48.5)	0.38 (9.7)	0.80 (20.3)
1/2	8	PM8	2.32 (58.9)	0.47 (11.9)	1.02 (25.8)
3/4	12	PM12	2.45 (62.2)	0.63 (16.0)	1.32 (33.5)
1	16	PM16	3.05 (77.5)	0.88 (22.4)	1.63 (41.4)
1 1/4	20	PM20	3.14 (79.8)	1.09 (27.7)	2.03 (51.6)
1 1/2	24	PM24	3.38 (85.9)	1.34 (34.0)	2.47 (62.6)
2	32	PM32	3.63 (92.2)	1.81 (46.0)	2.76 (70.0)
ISO/BSP Tapered					
1/4	4	MT4	1.70 (43.2)	0.28 (7.1)	0.65 (16.6)
3/8	6	MT6	1.91 (48.5)	0.38 (9.7)	0.80 (20.3)
1/2	8	MT8	2.32 (58.9)	0.47 (11.9)	1.02 (25.8)
3/4	12	MT12	2.45 (62.2)	0.63 (16.0)	1.32 (33.5)
1	16	MT16	3.05 (77.5)	0.88 (22.4)	1.63 (41.4)
1 1/4	20	MT20	3.14 (79.8)	1.09 (27.7)	2.03 (51.6)
1 1/2	24	MT24	3.38 (85.9)	1.34 (34.0)	2.47 (62.6)

Tube Butt Welds

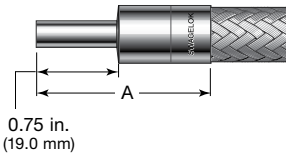

Tube Butt Weld Size in.	Wall Thickness in.	Nominal Hose Size Designator	End Connection Designator	Dimensions, in. (mm)		
				A	Minimum Inside Diameter	Maximum Outside Dimension
1/4	0.035	4	TB4	1.64 (41.7)	0.18 (4.6)	0.54 (13.7)
3/8	0.035	6	TB6	1.82 (46.2)	0.31 (7.9)	0.78 (19.8)
1/2	0.049	8	TB8	2.04 (51.8)	0.40 (10.2)	0.93 (23.6)
3/4	0.049	12	TB12	2.14 (54.4)	0.65 (16.5)	1.32 (33.5)
1	0.065	16	TB16	2.46 (62.5)	0.87 (22.1)	1.63 (41.4)

FL Series Metal Hose

Features

- Highly flexible all-metal hose.
- 316L stainless steel annular convoluted core.
- 1/4 and 1/2 in. sizes and working pressures from vacuum to 1500 psig (103 bar).
- Single braid layer of 321 stainless steel ensures hose pressure containment (M).
- End connections welded in accordance with ASME Boiler and Pressure Vessel Code Section IX.
- Exhibits strong performance in dynamic cycling applications.
- Commonly used in high-temperature vacuum and general purpose dynamic-cycling applications.
- Standard and custom assemblies available.
- Options include hose covers, hose tags, and additional helium leak testing. See page 83 for details.

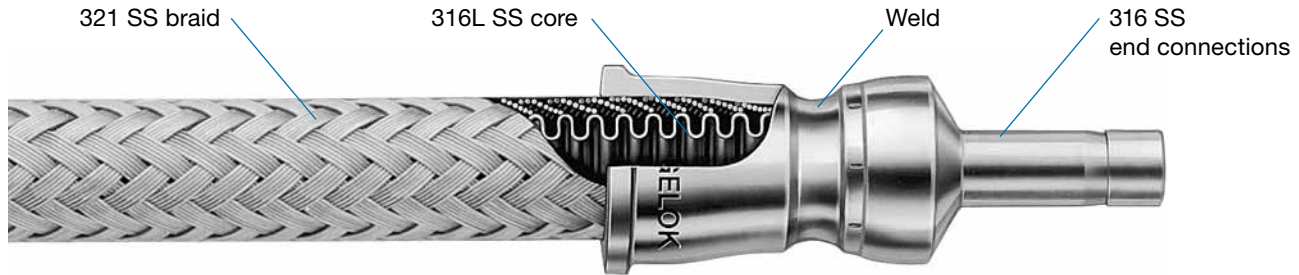

Technical Data

Nominal Hose Size in. (mm)	Inside Diameter in. (mm)	Outside Diameter in. (mm)	Minimum Center Line Bend Radius in. (cm)		Temperature Range °F (°C)	Working Pressure at -325 to 100°F (-200 to 37°C) Vacuum to ... psig (bar)	Burst Pressure at 70°F (20°C) psig (bar)	Bulk Hose Weight lb/ft (kg/m)
			Static	Dynamic				
1/4 (6.4)	0.24 (6.1)	0.47 (11.9)	1.00 (2.54)	5.50 (14.0)	-325 to 850 (-200 to 454)	1500 (103)	6000 (413)	0.12 (0.18)
1/2 (12.7)	0.47 (11.9)	0.82 (20.8)	1.75 (4.45)	7.00 (17.8)		1200 (82.6)	4800 (330)	0.24 (0.36)

Pressure-Temperature Ratings

Ratings are based on ASME Code for Pressure Piping, B31.1 Power Piping, and ASME Boiler and Pressure Vessel Code.

Nominal Hose Size, in.	1/4	1/2
Temperature °F (°C)	Working Pressure Vacuum to ... psig (bar)	
-325 (-200) to 100 (37)	1500 (103)	1200 (82.6)
200 (93)	1260 (86.8)	1008 (69.4)
300 (148)	1140 (78.5)	912 (62.8)
400 (204)	1050 (72.3)	840 (57.8)
500 (260)	975 (67.1)	780 (53.7)
600 (315)	930 (64.0)	744 (51.2)
700 (371)	885 (60.9)	708 (48.7)
800 (426)	855 (58.9)	684 (47.1)
850 (454)	840 (57.8)	672 (46.3)

Testing

Every Swagelok FL series hose assembly is inboard helium leak tested to a maximum leak rate of 1×10^{-5} std cm³/s.

For additional testing, see **Testing**, page 83.

Cleaning and Packaging

Swagelok FL series hose components are cleaned in accordance with Swagelok *Standard Cleaning and Packaging (SC-10)*, MS-06-62. Each hose is bagged individually and boxed; longer hoses are coiled, bagged, and boxed.

⚠ Do not subject flexible metal hose to pressure surges, shock, or pulsations, where the peak pressure is greater than 50 % of the working pressure rating.

See next page for ordering information and dimensions.

FL Series Metal Hose

Ordering Information and Dimensions

Standard Length Hose Assemblies

Select an ordering number.

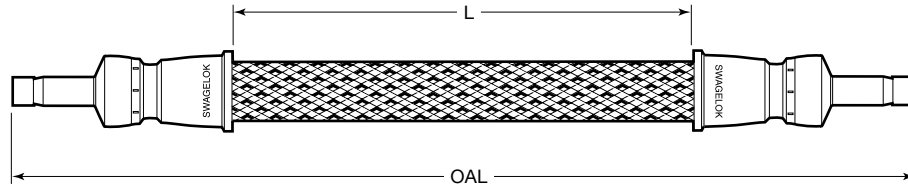

Swagelok Tube Adapter End Connections



Nominal Hose Size	Tube Adapter Size	Overall Length OAL	Ordering Number	Dimensions		
				Live Length L	Minimum Inside Diameter	Maximum Outside Dimension
Dimensions, in.		in. (cm)		in. (cm)	in. (mm)	
1/4	1/4	12.0 (30.5)	SS-FL4TA4TA4-12	8.48 (21.5)	0.16 (4.1)	0.66 (16.8)
		24.0 (61.0)	SS-FL4TA4TA4-24	20.5 (52.1)		
		36.0 (91.4)	SS-FL4TA4TA4-36	32.5 (82.6)		
		48.0 (122)	SS-FL4TA4TA4-48	44.5 (113)		
1/2	1/2	12.0 (30.5)	SS-FL8TA8TA8-12	7.50 (19.0)	0.37 (9.4)	1.01 (25.7)
		24.0 (61.0)	SS-FL8TA8TA8-24	19.5 (49.5)		
		36.0 (91.4)	SS-FL8TA8TA8-36	31.5 (80.0)		
		48.0 (122)	SS-FL8TA8TA8-48	43.5 (110)		
Dimensions, mm		cm (in.)		cm (in.)	mm (in.)	
1/4 in.	6	50.0 (19.7)	SS-FL4TM6TM6-50CM	41.1 (16.2)	4.1 (0.16)	16.8 (0.66)
		100 (39.4)	SS-FL4TM6TM6-100CM	91.2 (35.9)		
		150 (59.1)	SS-FL4TM6TM6-150CM	141 (55.6)		
1/2 in.	12	50.0 (19.7)	SS-FL8TM12TM12-50CM	38.6 (15.2)	8.9 (0.35)	25.7 (1.01)
		100 (39.4)	SS-FL8TM12TM12-100CM	88.6 (34.9)		
		150 (59.1)	SS-FL8TM12TM12-150CM	139 (54.7)		

FL Series Metal Hose

Ordering Information

Custom Hose Assemblies

Build a hose assembly ordering number by combining the designators in the sequence shown below.

Typical Ordering Number

1 2 3 4 4 5 6 5 6
SS - FL 4 TA4 PM4 - 28 F or **71 CM - F**
in. cm

1 Material

End Connections

SS = 316 stainless steel

2 Hose

FL = FL series metal hose

3 Nominal Hose Size, in.

4 = 1/4
8 = 1/2

4 End Connections

See **End Connection Designator** column in tables below.

Add designators in reverse alphanumeric order.

5 Overall Length

Inches or centimeters, in whole numbers. Include **CM** as shown for centimeter lengths.

6 Options

For multiple options, add designators in alphanumeric order with a dash between each designator. For hose lengths specified in centimeters, insert a dash as shown prior to the first option designator.

CRN = Lanyard tag with CRN

F = Fire jacket

F1 = Thermosleeve

H7 = Helium leak test (1×10^{-7} std cm³/s)

N3 = Nitrogen pressure test

T = Lanyard tag

T2 = Two lanyard tags

W = Hydrostatic test

Specify text for tags. See **Hose Tag Text** table, page 84.

See page 83 for detailed descriptions of options.

End Connections

Swagelok Tube Adapters

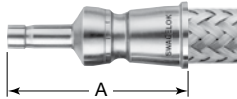

Tube Adapter Size	Nominal Hose Size Designator	End Connection Designator	A	Minimum Inside Diameter	Maximum Outside Dimension
Dimensions, in. (mm)					
1/4	4	TA4	1.76 (44.7)	0.16 (4.1)	0.66 (16.8)
3/8	4	TA6	1.79 (45.5)	0.27 (6.9)	0.66 (16.8)
	8	TA6	2.03 (51.6)		1.01 (25.7)
1/2	8	TA8	2.25 (57.2)	0.37 (9.4)	1.01 (25.7)
Dimensions, mm (in.)					
6	4	TM6	44.4 (1.75)	4.1 (0.16)	16.8 (0.66)
8	4	TM8	45.2 (1.78)	5.6 (0.22)	16.8 (0.66)
10	4	TM10	45.2 (1.78)	7.1 (0.28)	16.8 (0.66)
	8	TM10	51.3 (2.02)		25.7 (1.01)
12	8	TM12	57.4 (2.26)	8.9 (0.35)	25.7 (1.01)

Swagelok Tube Fittings

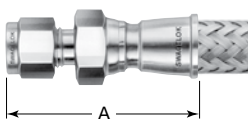

Tube Fitting Size	Nominal Hose Size Designator	End Connection Designator	A	Minimum Inside Diameter	Maximum Outside Dimension
Dimensions, in. (mm)					
1/4	4	SL4	1.94 (49.3)	0.19 (4.8)	0.80 (20.3)
3/8	8	SL6	2.22 (56.4)	0.28 (7.1)	1.23 (31.3)
1/2	8	SL8	2.33 (59.2)	0.41 (10.4)	1.23 (31.3)
Dimensions, mm (in.)					
6	4	SM6	49.3 (1.94)	4.8 (0.19)	20.3 (0.80)
10	8	SM10	56.4 (2.22)	7.9 (0.31)	31.3 (1.23)
12	8	SM12	59.2 (2.33)	9.7 (0.38)	31.3 (1.23)

See next page for more end connections.

FL Series Metal Hose

METAL

Rotatable Male VCR Metal Gasket Face Seal Fittings

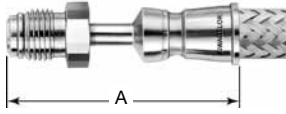

VCR Size in.	Nominal Hose Size Designator	End Connection Designator	Dimensions, in. (mm)		
			A	Minimum Inside Diameter	Maximum Outside Dimension
1/4	4	RM4	2.60 (66.0)	0.18 (4.6)	0.73 (18.4)
1/2	8	RM8	2.88 (73.2)	0.40 (10.2)	1.09 (27.7)

Rotatable Female VCR Metal Gasket Face Seal Fittings

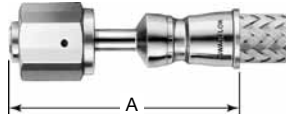

VCR Size in.	Nominal Hose Size Designator	End Connection Designator	Dimensions, in. (mm)		
			A	Minimum Inside Diameter	Maximum Outside Dimension
1/4	4	RF4	2.00 (50.8)	0.18 (4.6)	0.87 (22.1)
1/2	8	RF8	2.21 (56.1)	0.40 (10.2)	1.23 (31.3)

Female VCO O-Ring Face Seal Fittings

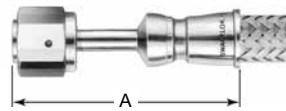

VCO Size in.	Nominal Hose Size Designator	End Connection Designator	Dimensions, in. (mm)		
			A	Minimum Inside Diameter	Maximum Outside Dimension
1/4	4	VF4	2.50 (63.5)	0.18 (4.6)	0.80 (20.3)
1/2	8	VF8	2.73 (69.3)	0.40 (10.2)	1.16 (29.5)

Male Pipe Threads, NPT and ISO/BSP Tapered (ISO 7)



NPT and ISO/BSP Tapered Size in.	Nominal Hose Size Designator	End Connection Designator	Dimensions, in. (mm)		
			A	Minimum Inside Diameter	Maximum Outside Dimension
NPT					
1/4	4	PM4	1.80 (45.7)	0.28 (7.1)	0.80 (20.3)
3/8	8	PM6	2.02 (51.3)	0.38 (9.7)	1.23 (31.3)
1/2	8	PM8	2.21 (56.1)	0.47 (11.9)	1.23 (31.3)
ISO/BSP Tapered					
1/4	4	MT4	1.80 (45.7)	0.28 (7.1)	0.80 (20.3)
1/2	8	MT8	2.21 (56.1)	0.47 (11.9)	1.23 (31.3)

Tube Butt Welds

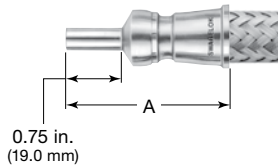

Tube Butt Weld Size in.	Wall Thickness in.	Nominal Hose Size Designator	End Connection Designator	Dimensions, in. (mm)		
				A	Minimum Inside Diameter	Maximum Outside Dimension
1/4	0.035	4	TB4	1.90 (48.3)	0.18 (4.6)	0.66 (16.8)
1/2	0.049	8	TB8	2.09 (53.1)	0.40 (10.2)	1.01 (25.7)

CT Series Convuluted Metal Tubing

Features

- Form-fit-and-stay, flexible, all-metal tubing.
- 321 stainless steel annular convoluted core (M).
- Size range of 1/4 through 1 1/2 in. and working pressures up to 100 psig (6.8 bar).
- Annealed material enables tubing to be compressed by at least 15 % and extended up to 50 % of manufactured length.
- Form-fit-and-stay capability of convoluted tubing can compensate for misalignment and system reroutes between static connections in vacuum or low-pressure static applications.
- Commonly used in high-temperature vacuum or low-pressure static applications.
- Standard and custom tubing lengths, custom tubing assemblies, and adapters for field assembly are available.
- Options include additional helium leak testing and tubing tags. See pages 27 and 84 for details.

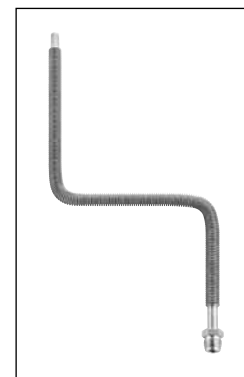
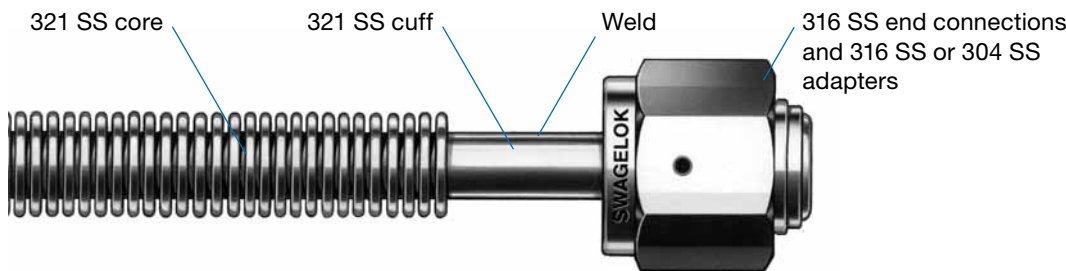

Form-fit-and-stay

Technical Data—CT Series Convuluted Metal Tubing

Nominal Tubing Size in.	Inside Diameter in. (mm)	Outside Diameter in. (mm)	Temperature Range °F (°C)	Working Pressure 10 ⁻⁹ torr to ... psig (bar)	Nominal Tubing Wall Thickness in. (mm)	Tubing Weight lb/ft (kg/m)	
1/4	0.25 (6.4)	0.38 (9.5)	70 to 1000 (20 to 537)	100 (6.8)	0.006 (0.15)	0.04 (0.06)	
3/8	0.38 (9.5)	0.58 (14.7)		25 (1.7)		0.006 (0.15)	0.07 (0.10)
1/2	0.50 (12.7)	0.71 (17.9)					0.09 (0.13)
3/4	0.75 (19.0)	1.08 (27.4)					0.19 (0.28)
1	1.00 (25.4)	1.36 (34.5)					0.23 (0.34)
1 1/2	1.50 (38.1)	1.92 (48.7)					0.34 (0.51)

Technical Data—End Connections and Adapters

End Connection Type	Material	Temperature Range °F (°C)	Availability
VCR Male and female	316 SS	70 to 1000 (20 to 537)	Factory welded
VCO Male and female	316 SS	70 to 400 (20 to 204)	
XBA adapter	304 SS (factory welded 1/2 in. and larger sizes; all sizes for field assembly) 316 SS (factory welded 1/4 and 3/8 in. sizes)	70 to 1000 (20 to 537)	Factory welded or field assembly
XOA adapter	304 SS	70 to 400 (20 to 204)	Field assembly

Testing

Every Swagelok CT series tubing assembly with factory-welded end connections is inboard helium leak tested to a maximum leak rate of 1.8×10^{-7} std cm³/s.

For additional testing, see **Ordering Information**, page 27.

Cleaning and Packaging

Swagelok CT series tubing assemblies and adapters are cleaned in accordance with Swagelok *Standard Cleaning and Packaging (SC-10)*, MS-06-62. Each item is individually packaged for cleanliness and protection.

⚠ Not suitable for dynamic flexing applications.

CT Series Convoluted Metal Tubing

Ordering Information and Dimensions

Standard Tubing

Select an ordering number.

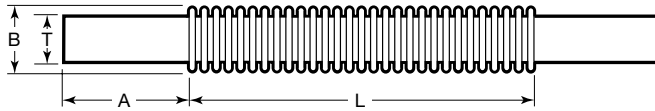

Nominal Tube Size T in.	Ordering Number	Dimensions, in. (mm)					Maximum Angular Displacement ^①
		Cuff Length A	Maximum Outside Diameter B	Live Length, L			
				Compressed	Manufactured	Extended	
1/4	321-4-X-2	0.75 (19.0)	0.38 (9.7)	1.50 (38.1)	2.00 (50.8)	3.00 (76.2)	180°
	321-4-X-4			3.25 (82.6)	4.00 (102)	6.00 (152)	
	321-4-X-6			4.75 (121)	6.00 (152)	9.00 (229)	360°
	321-4-X-12			9.00 (229)	12.0 (305)	18.0 (457)	
	321-4-X-24			18.0 (457)	24.0 (610)	36.0 (914)	
3/8	321-6-X-1	0.75 (19.0)	0.58 (14.7)	0.75 (19.0)	1.00 (25.4)	1.50 (38.1)	90°
	321-6-X-3			2.50 (63.5)	3.00 (76.2)	4.50 (114)	225°
	321-6-X-6			4.75 (121)	6.00 (152)	9.00 (229)	360°
	321-6-X-12			9.00 (229)	12.0 (305)	18.0 (457)	
	321-6-X-24			18.0 (457)	24.0 (610)	36.0 (914)	
1/2	321-8-X-1	1.00 (25.4)	0.71 (18.0)	0.75 (19.0)	1.00 (25.4)	1.50 (38.1)	45°
	321-8-X-3			2.50 (63.5)	3.00 (76.2)	4.50 (114)	180°
	321-8-X-6			4.75 (121)	6.00 (152)	9.00 (229)	360°
	321-8-X-12			9.00 (229)	12.0 (305)	18.0 (457)	
	321-8-X-24			18.0 (457)	24.0 (610)	36.0 (914)	
	321-8-X-36			24.0 (610)	36.0 (914)	54.0 (1370)	
3/4	321-12-X-1	1.00 (25.4)	1.08 (27.4)	0.75 (19.0)	1.00 (25.4)	1.50 (38.1)	30°
	321-12-X-3			2.50 (63.5)	3.00 (76.2)	4.50 (114)	90°
	321-12-X-6			4.75 (121)	6.00 (152)	9.00 (229)	180°
	321-12-X-12			9.00 (229)	12.0 (305)	18.0 (457)	360°
	321-12-X-24			18.0 (457)	24.0 (610)	36.0 (914)	
	321-12-X-36			24.0 (610)	36.0 (914)	54.0 (1370)	
1	321-16-X-1	1.00 (25.4)	1.36 (34.5)	0.75 (19.0)	1.00 (25.4)	1.50 (38.1)	20°
	321-16-X-3			2.50 (63.5)	3.00 (76.2)	4.50 (114)	90°
	321-16-X-6			4.75 (121)	6.00 (152)	9.00 (229)	180°
	321-16-X-12			9.00 (229)	12.0 (305)	18.0 (457)	360°
	321-16-X-24			18.0 (457)	24.0 (610)	36.0 (914)	
	321-16-X-36			24.0 (610)	36.0 (914)	54.0 (1370)	
1 1/2	321-24-X-1	1.00 (25.4)	1.92 (48.8)	0.75 (19.0)	1.00 (25.4)	1.50 (38.1)	15°
	321-24-X-3			2.50 (63.5)	3.00 (76.2)	4.50 (114)	60°
	321-24-X-6			4.75 (121)	6.00 (152)	9.00 (229)	120°
	321-24-X-12			9.00 (229)	12.0 (305)	18.0 (457)	240°
	321-24-X-24			18.0 (457)	24.0 (610)	36.0 (914)	360°
	321-24-X-36			24.0 (610)	36.0 (914)	54.0 (1370)	

① Angular displacement based on nominal live length, as manufactured. Angular displacement is not recommended for applications involving pressure surges.

CT Series Convuluted Metal Tubing

Ordering Information

Custom Tubing and Tubing Assemblies

Build a custom tubing or tubing assembly ordering number by combining the designators in the sequence shown below.

Typical Ordering Number

1 2 3 4 5 6
3 2 1 - 4 - X - 36 F M R - H L T

1 Material

Tubing

321 = 321 stainless steel

2 Tube OD, in.

4 = 1/4
 6 = 3/8
 8 = 1/2
 12 = 3/4
 16 = 1
 24 = 1 1/2

3 Tubing

X = CT series convoluted metal tubing

4 Manufactured Live Length

Insert length in inches, in whole numbers.

1/4 in. tubing size: 1 to 120 in.
 All other tubing sizes: 1 to 96 in.

Manufactured lengths over 48 in. but less than 96 in. are spliced from two pieces; manufactured lengths over 96 in. but less than 120 in. are spliced from three pieces.

To calculate the overall length of the custom tubing assembly, add the manufactured live length (L) and two times the cuff length (A) for the appropriate sized hose.

5 End Connections

For tubing assemblies.

First End Connection	Second End Connection	Designator
XBA adapter	None	-B1
	XBA adapter	-B2
	Female VCR	FRB
	Male VCR	MRB
	Female VCO	FOB
Female VCR	None	FR
	Female VCR	DFR
	Male VCR	FMR
	Male VCO	FRMO
Male VCR	None	MR
	Male VCR	DMR
Female VCO	None	FO
	Female VCO	DFO
	Male VCR	FOMR
	Male VCO	FMO
Male VCO	None	MO
	Male VCO	DMO

6 Options

For tubing assemblies.

For multiple options, add designators in alphanumeric order with a dash between each designator.

CRN = Lanyard tag with CRN

HLT = Inboard helium leak test with certification (1 × 10⁻⁹ std cm³/s maximum leak rate)

Specify text for tags. See **Hose Tag Text** table, page 84.

See next page for factory-welded end connections.

CT Series Convoluted Metal Tubing

Factory-Welded End Connections

Rotatable Female VCR Metal Gasket Face Seal Fittings

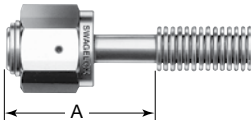

VCR Size in.	Dimensions, in. (mm)		
	A	Minimum Inside Diameter	Maximum Outside Dimension
1/4	1.95 (49.5)	0.13 (3.3)	0.87 (22.1)
3/8	2.06 (52.3)	0.23 (5.8)	1.23 (31.3)
1/2	2.25 (57.2)	0.33 (8.4)	1.23 (31.3)

Rotatable Male VCR Metal Gasket Face Seal Fittings

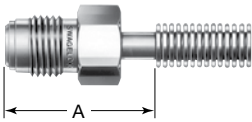

VCR Size in.	Dimensions, in. (mm)		
	A	Minimum Inside Diameter	Maximum Outside Dimension
1/4	1.95 (49.5)	0.18 (4.6)	0.73 (18.4)
3/8	2.06 (52.3)	0.28 (7.1)	1.09 (27.6)
1/2	2.25 (57.2)	0.40 (10.2)	1.09 (27.6)

Female VCO O-Ring Face Seal Fittings

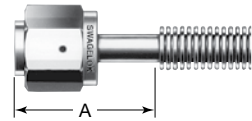

VCO Size in.	Dimensions, in. (mm)		
	A	Minimum Inside Diameter	Maximum Outside Dimension
1/4	1.68 (42.7)	0.13 (3.3)	0.80 (20.3)
3/8	1.40 (35.6)	0.23 (5.8)	1.16 (29.5)
1/2	1.81 (46.0)	0.33 (8.4)	1.16 (29.5)

Male VCO O-Ring Face Seal Fittings

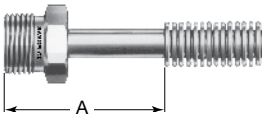

VCO Size in.	Dimensions, in. (mm)		
	A	Minimum Inside Diameter	Maximum Outside Dimension
1/4	2.13 (54.1)	0.13 (3.3)	0.73 (18.4)
3/8	2.27 (57.7)	0.23 (5.8)	1.09 (27.6)
1/2	2.46 (62.5)	0.33 (8.4)	1.09 (27.6)

XBA Adapters

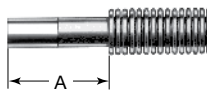

Adapter Size in.	Dimensions, in. (mm)		
	A	Minimum Inside Diameter	Maximum Outside Dimension
1/4	1.55 (39.4)	0.18 (4.6)	0.38 (9.7)
3/8	1.58 (40.1)	0.31 (7.9)	0.58 (14.7)
1/2	1.94 (49.3)	0.39 (9.9)	1.08 (27.4)
3/4	2.03 (51.6)	0.61 (15.5)	1.08 (27.4)
1	2.31 (58.7)	0.86 (21.8)	1.36 (34.5)
1 1/2	3.06 (77.7)	1.36 (34.5)	1.92 (48.8)

CT Series Convuluted Metal Tubing

End Connections for Field Assembly

XBA Adapters

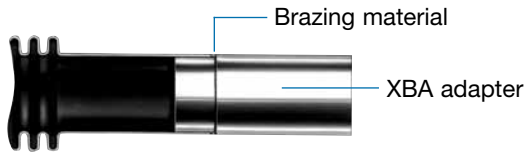

- XBA adapters are brazed or soldered to convuluted vacuum tubing.
- XBA adapters allow for connecting to socket and butt weld fittings, Swagelok tube fittings, and Ultra-Torr™ vacuum fittings.
- Material is 304 stainless steel.

Ordering Information and Dimensions

Select an adapter ordering number.

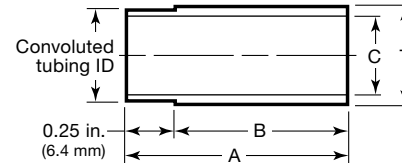

T in.	Ordering Number	Dimensions, in. (mm)		
		A	B	C
1/4	304-4-XBA	0.94 (23.9)	0.69 (17.5)	0.16 (4.1)
3/8	304-6-XBA	1.00 (25.4)	0.75 (19.0)	0.28 (7.1)
1/2	304-8-XBA	1.19 (30.2)	0.94 (23.9)	0.38 (9.7)
3/4	304-12-XBA	1.28 (32.5)	1.03 (26.2)	0.60 (15.2)
1	304-16-XBA ^①	1.56 (39.6)	1.31 (33.3)	0.85 (21.6)
1 1/2	304-24-XBA ^①	2.31 (58.7)	2.06 (52.3)	1.35 (34.3)

^① Not recommended for gas service with Swagelok tube fitting.

XOA Adapters

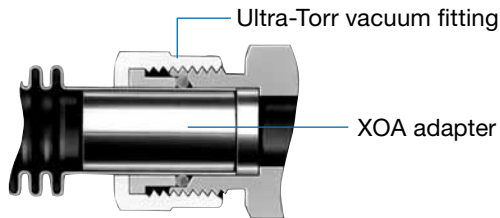

- XOA adapters support the tubing cuff when using convuluted vacuum tubing products with Ultra-Torr vacuum fittings.
- XOA adapters provide a leak-tight connection and are reusable.
- Material is 304 stainless steel.

Ordering Information and Dimensions

Select an adapter ordering number.

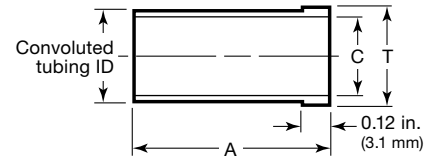

T in.	Ordering Number	Dimensions, in. (mm)	
		A	C
1/4	304-4-XOA	0.75 (19.0)	0.16 (4.1)
3/8	304-6-XOA		0.28 (7.1)
1/2	304-8-XOA	1.00 (25.4)	0.38 (9.7)
3/4	304-12-XOA		0.60 (15.2)
1	304-16-XOA		0.85 (21.6)
1 1/2	304-24-XOA		1.35 (34.3)

Ultra-Torr Vacuum Fittings

See the Swagelok *Ultra-Torr Vacuum Fittings* catalog, MS-01-32, for more information.

T Series PTFE Hose

Features

- PTFE hose with permeation-resistant features.
- Smooth-bore PTFE core.
- Size range of 1/4 through 1 in. and working pressures up to 3000 psig (206 bar).
- Single braid layer of 304 stainless steel (316L SS and alloy 400 available) ensures hose pressure containment and protects the core from abrasion (M).
- PTFE material complies with FDA regulation 21CFR Part 177.1550 and 3-A for contact with water, food, and beverage.
- Optional carbon black-filled PTFE core is available for applications that require static dissipation (Ω).
- Select static dissipative hose assemblies are approved to ECE R110; see page 84 for more information.
- Commonly used where chemical compatibility and permeation resistance is desired.
- Standard and custom assemblies available.
- Options include hose covers and hose tags. See page 83 for details.

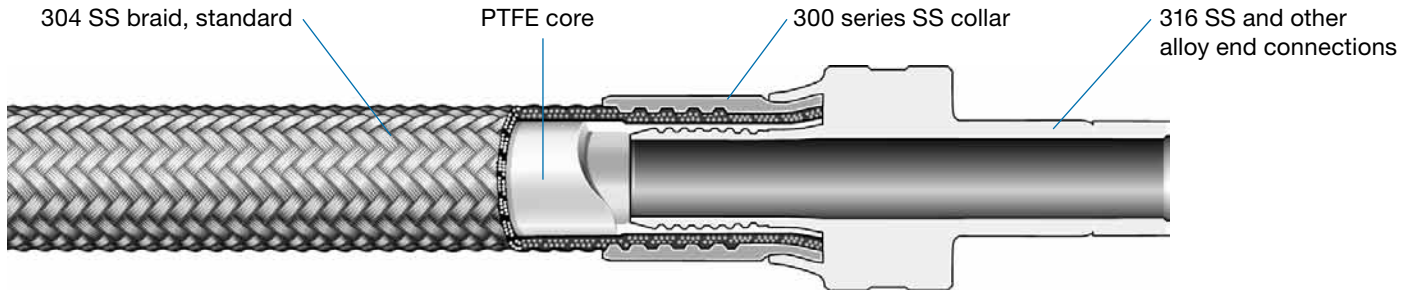

Technical Data

Nominal Hose Size in. (mm)	Inside Diameter in. (mm)	Outside Diameter in. (mm)	Minimum Inside Bend Radius in. (cm)		Temperature Range °F (°C)	Vacuum (28.5 in.Hg [96.5 kPa]) Rated to ... °F (°C)	Working Pressure at 70°F (20°C) psig (bar)	Burst Pressure at 70°F (20°C) psig (bar)	Bulk Hose Weight lb/ft (kg/m)
			Static	Dynamic					
304 SS Braid (TH and TC)									
1/4 (6.4)	0.19 (4.8)	0.31 (7.9)	1.50 (3.81)	2.00 (5.08)	-65 to 450 (-53 to 230)	450 (230)	3000 (206)	12 000 (826)	0.08 (0.12)
3/8 (9.5)	0.31 (7.9)	0.44 (11.1)	3.50 (8.89)	5.00 (12.7)		450 (230)	2500 (172)	10 000 (689)	0.12 (0.17)
1/2 (12.7)	0.41 (10.3)	0.56 (14.3)	4.50 (11.4)	6.00 (15.2)		450 (230)	2000 (137)	8 000 (551)	0.15 (0.22)
3/4 (19.0)	0.63 (15.9)	0.81 (20.6)	6.00 (15.2)	7.50 (19.0)		450 (230)	1500 (103)	6 000 (413)	0.28 (0.41)
1 (25.4)	0.88 (22.2)	1.03 (26.2)	9.00 (22.9)	11.3 (28.7)		400 (204)	1000 (68.9)	4 000 (275)	0.39 (0.58)
Alloy 400 Braid (TL4)									
1/4 (6.4)	0.19 (4.8)	0.31 (7.9)	1.50 (3.81)	2.00 (5.08)	-65 to 450 (-53 to 230)	450 (230)	1500 (103)	6 000 (413)	0.08 (0.12)

Pressure-Temperature Ratings

Ratings are based on burst testing.

Braid Material	304 SS (TH and TC)					Alloy 400 (TL4)	
	Nominal Hose Size in.						
	1/4	3/8	1/2	3/4	1	1/4	
Temperature °F (°C)	Working Pressure, psig (bar)						
0 (-17) to 100 (37) 200 (93)	-65 (-53)	2250 (155)	1875 (129)	1500 (103)	1125 (77.5)	750 (51.6)	1500 (103)
	3000 (206)	2500 (172)	2000 (137)	1500 (103)	1000 (68.9)	1500 (103)	
	1740 (119)	1450 (99.9)	1160 (79.9)	870 (59.9)	580 (39.9)	1305 (89.9)	
300 (148) 400 (204) 450 (230)	1560 (107)	1300 (89.5)	1040 (71.6)	780 (53.7)	520 (35.8)	1215 (83.7)	
	1440 (99.2)	1200 (82.6)	960 (66.1)	720 (49.6)	480 (33.0)	1185 (81.6)	
	1380 (95.0)	1150 (79.2)	920 (63.3)	690 (47.5)	460 (31.6)	1170 (80.6)	

Testing

Every Swagelok T series hose assembly is pressure tested with water for 30 to 60 seconds at 1.5 times the working pressure to a requirement of no visible leakage at ambient temperature.

Cleaning and Packaging

Swagelok T series hose components are cleaned in accordance with Swagelok *Standard Cleaning and Packaging (SC-10)*, MS-06-62. Each hose is bagged individually and boxed; longer hoses are coiled, bagged, and boxed.

T Series PTFE Hose

Ordering Information and Dimensions

Standard Length Hose Assemblies

Select an ordering number.

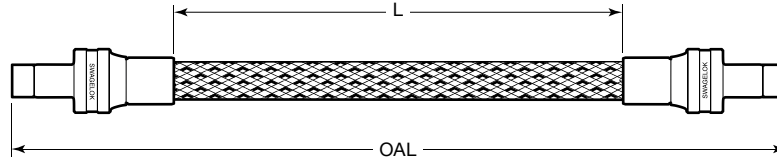

Swagelok Tube Adapter End Connections



Nominal Hose Size	Tube Adapter Size	Overall Length OAL	Ordering Number	Dimensions		
				Live Length L	Minimum Inside Diameter	Maximum Outside Dimension
Dimensions, in.		in. (cm)		in. (cm)	in. (mm)	
1/4	1/4	8.00 (20.3)	SS-4BHT-6	4.72 (12.0)	0.16 (4.1)	0.54 (13.7)
		14.0 (35.6)	SS-4BHT-12	10.7 (27.2)		
		20.0 (50.8)	SS-4BHT-18	16.7 (42.4)		
		26.0 (66.0)	SS-4BHT-24	22.7 (57.7)		
		38.0 (96.5)	SS-4BHT-36	34.7 (88.1)		
		50.0 (127)	SS-4BHT-48	46.7 (119)		
		62.0 (157)	SS-4BHT-60	58.7 (149)		
		74.0 (188)	SS-4BHT-72	70.7 (180)		
		122 (310)	SS-4BHT-120	119 (302)		
3/8	3/8	14.0 (35.6)	SS-6BHT-12	10.4 (26.4)	0.27 (6.9)	0.73 (18.5)
		20.0 (50.8)	SS-6BHT-18	16.4 (41.7)		
		26.0 (66.0)	SS-6BHT-24	22.4 (56.9)		
		38.0 (96.5)	SS-6BHT-36	34.4 (87.4)		
		50.0 (127)	SS-6BHT-48	46.4 (118)		
		62.0 (157)	SS-6BHT-60	58.4 (148)		
		74.0 (188)	SS-6BHT-72	70.4 (179)		
1/2	1/2	14.5 (36.8)	SS-8BHT-12	10.0 (25.4)	0.36 (9.1)	0.86 (21.8)
		26.5 (67.3)	SS-8BHT-24	22.0 (55.9)		
		38.5 (97.8)	SS-8BHT-36	34.0 (86.4)		
		50.5 (128)	SS-8BHT-48	46.0 (117)		
		62.5 (159)	SS-8BHT-60	58.0 (147)		
		74.5 (189)	SS-8BHT-72	70.0 (178)		
3/4	3/4	26.5 (67.3)	SS-12BHT-24	21.0 (53.3)	0.53 (13.5)	1.04 (26.4)
		38.5 (97.8)	SS-12BHT-36	33.1 (84.1)		
1	1	39.5 (100)	SS-16BHT-36	32.3 (82.0)	0.80 (20.3)	1.36 (34.5)
		51.5 (131)	SS-16BHT-48	44.3 (113)		
Dimensions, mm		cm (in.)		cm (in.)	mm (in.)	
1/4 in.	6	35.6 (14.0)	SS-4MBHT-12	27.2 (10.7)	4.1 (0.16)	13.7 (0.54)
		66.0 (26.0)	SS-4MBHT-24	57.6 (22.7)		
		96.5 (38.0)	SS-4MBHT-36	88.1 (34.7)		
1/2 in.	12	67.3 (26.5)	SS-8MBHT-24	54.2 (21.3)	8.4 (0.33)	21.8 (0.86)
		97.8 (38.5)	SS-8MBHT-36	84.7 (33.3)		

FLUOROPOLYMER

See next page for more hose assemblies.

T Series PTFE Hose

Female VCO O-Ring Face Seal Fitting End Connections



Nominal Hose Size in.	VCO Size in.	Overall Length OAL in. (cm)	Ordering Number	Dimensions		
				Live Length L in. (cm)	Minimum Inside Diameter in. (mm)	Maximum Outside Dimension in. (mm)
1/4	1/4	13.5 (34.3)	SS-4BHO-12	10.1 (25.7)	0.16 (4.1)	0.80 (20.3)
		25.5 (64.8)	SS-4BHO-24	22.1 (56.1)		
		37.5 (95.3)	SS-4BHO-36	34.1 (86.6)		
1/2	1/2	13.5 (34.3)	SS-8BHO-12	9.5 (24.1)	0.36 (9.1)	1.16 (29.5)
		25.5 (64.8)	SS-8BHO-24	21.5 (54.6)		
		37.5 (95.3)	SS-8BHO-36	33.5 (85.1)		
		49.5 (126)	SS-8BHO-48	45.5 (116)		

Ordering Information

Custom Hose Assemblies

Build a hose assembly ordering number by combining the designators in the sequence shown below.

Typical Ordering Number

1 2 3 4 4 5 6 5 6
SS - TH 4 TA 4 SL 2 - 28 Z or **71 CM - Z**
|-----in.-----| |-----cm-----|

1 Material

End Connections

- SS** = 316 stainless steel
- C20** = Alloy 20
- M** = Alloy 400
- INC** = Alloy 600
- HC** = Alloy C-276
- TI** = Titanium, grade 4

2 Hose

- TH** = T series PTFE hose with 304 SS braid
- TC** = T series carbon black-filled PTFE hose with 304 SS braid (Ω)
- TL** = T series PTFE hose with alloy 400 braid (1/4 in. hose size *only*)

3 Nominal Hose Size, in.

- 4** = 1/4
- 6** = 3/8
- 8** = 1/2
- 12** = 3/4
- 16** = 1

4 End Connections

See **End Connection Designator** column in tables on next page.

Add designators in reverse alphanumeric order.

5 Overall Length

Inches or centimeters, in whole numbers. Include **CM** as shown for centimeter lengths.

6 Options

For multiple options, add designators in alphanumeric order with a dash between each designator. For hose lengths specified in centimeters, insert a dash as shown prior to the first option designator.

- CRN** = Lanyard tag with CRN
- F** = Fire jacket
- F1** = Thermosleeve
- N3** = Nitrogen pressure test
- S** = 302 SS spring guard, hose-length
- T** = Lanyard tag
- T2** = Two lanyard tags
- W** = Hydrostatic test
- Z** = 316L SS braid material and 316 SS collar material (1/4 and 3/8 in. TH series hoses *only*)
- 093** = ECE R110 approval
(See page 84 for the nominal sizes and end connections available.)

Specify text for tags. see **Hose Tag Text** table, page 84.

See page 83 for detailed descriptions of options.

T Series PTFE Hose

End Connections

Swagelok Tube Adapters

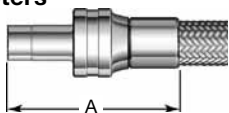

Tube Adapter Size	Nominal Hose Size Designator	End Connection Designator	Dimensions		
			A	Minimum Inside Diameter	Maximum Outside Dimension
Dimensions, in. (mm)					
1/4	4	TA4	1.64 (41.7)	0.16 (4.1)	0.54 (13.7)
3/8	6	TA6	1.74 (44.2)	0.27 (6.9)	0.73 (18.5)
	8	TA6	2.34 (59.4)		
1/2	8	TA8	2.26 (57.4)	0.36 (9.1)	0.86 (21.8)
3/4	12	TA12	2.72 (69.1)	0.53 (13.5)	1.04 (26.4)
	16	TA12	3.33 (84.6)	0.56 (14.2)	1.36 (34.5)
1	12	TA16	2.93 (74.4)	0.58 (14.7)	1.34 (34.0)
	16	TA16	3.61 (91.7)	0.80 (20.3)	1.36 (34.5)
Dimensions, mm (in.)					
6	4	TM6	42.2 (1.66)	4.1 (0.16)	13.7 (0.54)
8	4	TM8	50.5 (1.99)	4.1 (0.16)	13.7 (0.54)
10	6	TM10	52.3 (2.06)	6.9 (0.27)	15.5 (0.61)
12	8	TM12	67.1 (2.64)	8.4 (0.33)	20.1 (0.79)
18	12	TM18	67.6 (2.66)	13.5 (0.53)	26.4 (1.04)
25	16	TM25	89.7 (3.53)	19.0 (0.75)	34.5 (1.36)

Female VCO O-Ring Face Seal Fittings

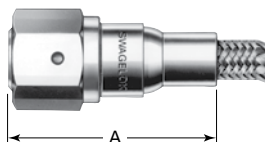

VCO Size in.	Nominal Hose Size Designator	End Connection Designator	Dimensions, in. (mm)		
			A	Minimum Inside Diameter	Maximum Outside Dimension
1/4	4	VF4	1.69 (42.9)	0.16 (4.1)	0.80 (20.3)
1/2	6	VF8	1.76 (44.7)	0.27 (6.9)	1.16 (29.5)
	8	VF8	2.02 (51.3)	0.36 (9.1)	
3/4	12	VF12	2.15 (54.6)	0.58 (14.7)	1.26 (31.9)
	16	VF12	2.75 (69.9)	0.63 (16.0)	
1	16	VF16	2.72 (69.1)	0.80 (20.3)	2.03 (51.6)

Swagelok Tube Fittings

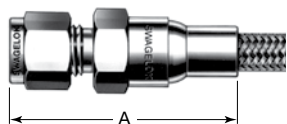

Tube Fitting Size	Nominal Hose Size Designator	End Connection Designator	Dimensions		
			A	Minimum Inside Diameter	Maximum Outside Dimension
Dimensions, in. (mm)					
1/8	4	SL2	1.93 (49.0)	0.09 (2.3)	0.65 (16.6)
1/4	4	SL4	1.97 (50.0)	0.16 (4.1)	0.65 (16.6)
3/8	6	SL6	2.20 (55.9)	0.27 (6.9)	0.87 (22.1)
1/2	8	SL8	2.50 (63.5)	0.36 (9.1)	1.09 (27.6)
3/4	12	SL12	2.81 (71.4)	0.58 (14.7)	1.31 (33.1)
Dimensions, mm (in.)					
6	4	SM6	50.0 (1.97)	4.1 (0.16)	16.6 (0.65)
10	6	SM10	57.2 (2.25)	6.9 (0.27)	22.1 (0.87)
12	8	SM12	63.5 (2.50)	9.1 (0.36)	27.6 (1.09)
18	12	SM18	71.4 (2.81)	14.7 (0.58)	33.1 (1.31)

See next page for more end connections.

T Series PTFE Hose

Female Pipe Threads,
NPT and ISO/BSP Tapered
(ISO 7)

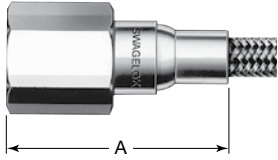

Female NPT and ISO/BSP Tapered Size in.	Nominal Hose Size Designator	End Connection Designator	Dimensions, in. (mm)		
			A	Minimum Inside Diameter	Maximum Outside Dimension
NPT					
1/4	4	PF4	1.88 (47.8)	0.16 (4.1)	0.87 (22.1)
	6	PF4	1.84 (46.7)	0.27 (6.9)	
3/8	6	PF6	1.95 (49.5)	0.27 (6.9)	1.02 (25.8)
1/2	8	PF8	2.49 (63.3)	0.36 (9.1)	1.23 (31.3)
3/4	12	PF12	2.51 (63.8)	0.58 (14.7)	1.52 (38.7)
ISO/BSP Tapered					
1/4	4	FT4	1.88 (47.8)	0.16 (4.1)	0.87 (22.1)
1/2	8	FT8	2.49 (63.3)	0.36 (9.1)	1.23 (31.3)

Male Pipe Threads,
NPT and ISO/BSP Tapered
(ISO 7)

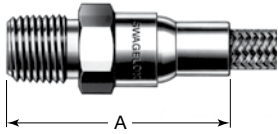

Male NPT and ISO/BSP Tapered Size in.	Nominal Hose Size Designator	End Connection Designator	Dimensions, in. (mm)		
			A	Minimum Inside Diameter	Maximum Outside Dimension
NPT					
1/4	4	PM4	1.88 (47.8)	0.16 (4.1)	0.80 (20.3)
	6	PM4	1.91 (48.5)	0.27 (6.9)	
	8	PM4	2.17 (55.1)	0.28 (7.1)	
3/8	6	PM6	1.91 (48.5)	0.27 (6.9)	0.80 (20.3)
	8	PM6	2.17 (55.1)	0.36 (9.1)	
1/2	8	PM8	2.39 (60.7)	0.36 (9.1)	1.02 (25.8)
	12	PM8	2.41 (61.2)	0.47 (11.9)	1.23 (31.3)
3/4	12	PM12	2.41 (61.2)	0.58 (14.7)	1.23 (31.3)
	16	PM12	3.00 (76.2)	0.63 (16.0)	1.31 (33.1)
1	16	PM16	3.26 (82.8)	0.80 (20.3)	1.60 (40.5)
ISO/BSP Tapered					
1/4	4	MT4	1.88 (47.8)	0.16 (4.1)	0.80 (20.3)
1/2	8	MT8	2.39 (60.7)	0.36 (9.1)	1.02 (25.8)
3/4	12	MT12	2.41 (61.2)	0.58 (14.7)	1.23 (31.3)
1	16	MT16	3.26 (82.8)	0.80 (20.3)	1.60 (40.5)

Female VCR Metal Gasket
Face Seal Fittings

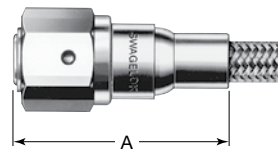

VCR Size in.	Nominal Hose Size Designator	End Connection Designator	Dimensions, in. (mm)		
			A	Minimum Inside Diameter	Maximum Outside Dimension
1/4	4	RF4	1.84 (46.7)	0.16 (4.1)	0.87 (22.1)
1/2	8	RF8	2.24 (56.9)	0.36 (9.1)	1.23 (31.3)
3/4	12	RF12	2.46 (62.5)	0.58 (14.7)	1.74 (44.2)
1	16	RF16	3.39 (86.1)	0.80 (20.3)	2.03 (51.6)

T Series PTFE Hose

SAE 37° (JIC) Male Flare

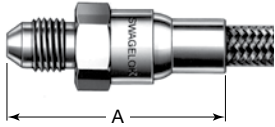

JIC Flare Size in.	Nominal Hose Size Designator	End Connection Designator	Dimensions, in. (mm)		
			A	Minimum Inside Diameter	Maximum Outside Dimension
1/4	4	AN4	1.88 (47.8)	0.16 (4.1)	0.80 (20.3)
3/8	6	AN6	1.91 (48.5)	0.27 (6.9)	0.73 (18.4)
1/2	8	AN8	2.39 (60.7)	0.36 (9.1)	1.02 (25.8)

SAE 37° (JIC) Female Swivel

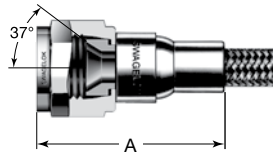

JIC Swivel Size in.	Nominal Hose Size Designator	End Connection Designator	Dimensions, in. (mm)		
			A	Minimum Inside Diameter	Maximum Outside Dimension
1/4	4	AS4	1.62 (41.1)	0.16 (4.1)	0.65 (16.6)
3/8	6	AS6	1.76 (44.7)	0.27 (6.9)	0.87 (22.1)
1/2	8	AS8	2.16 (54.9)	0.36 (9.1)	1.09 (27.6)

Sanitary Kwik-Clamps

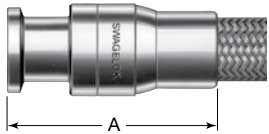

Kwik-Clamp Size in.	Nominal Hose Size Designator	End Connection Designator	Dimensions, in. (mm)		
			A	Minimum Inside Diameter	Maximum Outside Dimension
1/2	8	KC8	2.15 (54.6)	0.36 (9.1)	0.99 (25.2)
3/4	12	KC12	2.17 (55.1)	0.58 (14.7)	0.99 (25.2)
1	16	KC16	2.95 (74.9)	0.80 (20.3)	1.98 (50.3)
1 1/2	16	KC24	2.39 (60.7)	0.80 (20.3)	1.98 (50.3)

Working pressure and temperature ratings of hoses with sanitary Kwik-Clamp end connections may be limited by the gasket material and clamp. Maximum pressure rating is 300 psig (20.6 bar).

Coreflex B Series PTFE Hose

Features

- General purpose PTFE hose.
- Smooth-bore PTFE core.
- 1/8 in. size and working pressure of 3000 psig (206 bar).
- 304 stainless steel braid ensures hose pressure containment and protects the core from abrasion (M).
- PTFE material complies with FDA regulation 21CFR Part 177.1550 and USP <88> Class VI.
- Commonly used where chemical compatibility is desired.
- Custom hose lengths and end connections available.
- Options include hose covers and hose tags. See page 83 for details.

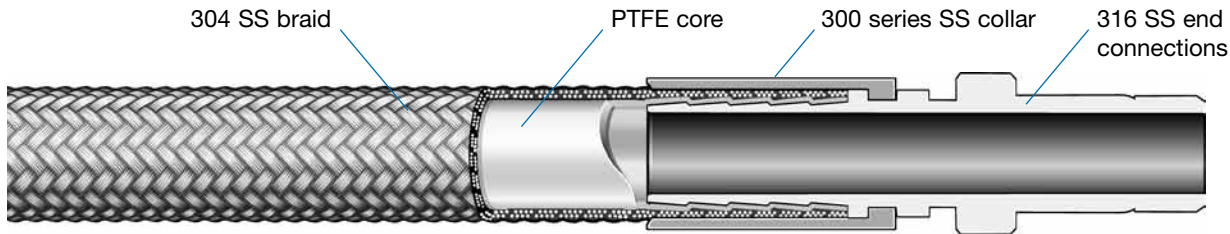

Technical Data

Nominal Hose Size in. (mm)	Inside Diameter in. (mm)	Outside Diameter in. (mm)	Minimum Inside Bend Radius in. (cm)		Temperature Range °F (°C)	Vacuum (28.5 in.Hg [96.5 kPa]) Rated to ... °F (°C)	Working Pressure at -65 to 450°F (-53 to 230°C) psig (bar)	Burst Pressure at 70°F (20°C) psig (bar)	Bulk Hose Weight lb/ft (kg/m)
			Static	Dynamic					
1/8 (3.2)	0.125 (3.2)	0.25 (6.4)	1.50 (3.81)	3.75 (9.52)	-65 to 450 (-53 to 230)	450 (230)	3000 (206)	12 000 (826)	0.05 (0.07)

Pressure-temperature ratings may be limited by the end connections.

Pressure-Temperature Ratings

Temperature °F (°C)	Working Pressure psig (bar)
-65 (-53) to 450 (230)	3000 (206)

Testing

Every Swagelok B series hose assembly is pressure tested with water at room temperature for 30 seconds to a requirement of no detectable leakage. Testing is performed at a minimum of 1000 psig (69 bar), or 225 psig (15.5 bar) if an end connection is rated below 1000 psig (69 bar).

Cleaning and Packaging

Every Swagelok B series hose component is cleaned in accordance with Swagelok *Standard Cleaning and Packaging (SC-10)*, MS-06-62.

Coreflex B Series PTFE Hose

Ordering Information

Custom Hose Assemblies

Build a hose assembly ordering number by combining the designators in the sequence shown below.

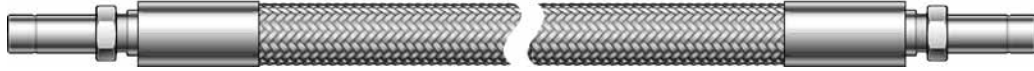

Typical Ordering Number

1 2 3 4 4 5 6 5 6
 SS - BT 2 TA 2 PM 2 - 28 MB or 71 CM - MB
in. cm

1 Material

End Connections

SS = 316 stainless steel

2 Hose

BT = B series PTFE hose

3 Nominal Hose Size, in.

2 = 1/8

4 End Connections

See **End Connection Designator** column in tables on pages 52 to 60

Add designators in reverse alphanumeric order.

5 Overall Length

Inches or centimeters, in whole numbers. Include **CM** as shown for centimeter lengths.

Typical maximum one-piece hose length is 900 in. or 2286 cm. Longer assemblies may be spliced; specify splices under **Options**. See page 4 for more information about splices.

6 Options

For multiple options, add designators in alphanumeric order with a dash between each designator. For hose lengths specified in centimeters, insert a dash as shown prior to the first option designator.

F = Fire jacket

Splices

SP1 = 1 splice

SP2 = 2 splices

Mat Tags

MA = Gray

MO = Orange

MB = Blue

MP = Purple

MC = Brown

MR = Red

MG = Green

MW = White

MK = Black

MY = Yellow

MN = Pink

Other Tags

T = Lanyard tag

T2 = Two lanyard tags

Specify text for tags. see **Hose Tag Text** table, page 84.

See page 83 for detailed descriptions of options.

Coreflex X Series PTFE Hose

Features

- Highly flexible PTFE hose.
- Smooth-bore PTFE core.
- Size range of 1/4 through 1 in. and working pressures up to 3500 psig (241 bar).
- Fiber braid bonded to the core with a patent-pending process supports core to resist kinking.
- 304 stainless steel braid protects the core from abrasion and enhances hose pressure rating (M).
- PTFE material complies with FDA regulation 21CFR Part 177.1550, USP <88> Class VI, and 3-A.
- Optional carbon black-filled PTFE core is available for applications that require static dissipation (Ω).
- Commonly used where flexibility and chemical compatibility are desired.
- Custom hose lengths and end connections available.
- Options include hose covers and hose tags. See page 83 for details.

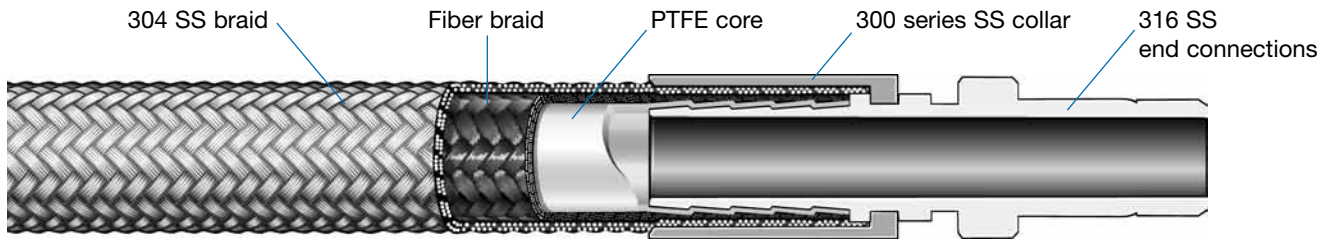

Technical Data

Nominal Hose Size in. (mm)	Inside Diameter in. (mm)	Outside Diameter in. (mm)	Minimum Inside Bend Radius in. (cm)		Temperature Range °F (°C)	Vacuum (28.5 in.Hg [96.5 kPa]) Rated to ... °F (°C)	Working Pressure at 70°F (20°C) psig (bar)	Burst Pressure at 70°F (20°C) psig (bar)	Bulk Hose Weight lb/ft (kg/m)
			Static	Dynamic					
1/4 (6.4)	0.25 (6.4)	0.46 (11.7)	1.25 (3.18)	4.20 (10.7)	-65 to 450 (-53 to 230)	450 (230)	3500 (241)	14 000 (964)	0.13 (0.19)
3/8 (9.6)	0.38 (9.6)	0.57 (14.5)	1.75 (4.44)	4.40 (11.2)		450 (230)	3000 (206)	12 000 (826)	0.17 (0.25)
1/2 (12.7)	0.50 (12.7)	0.76 (19.3)	2.50 (6.35)	6.38 (16.2)		450 (230)	1800 (124)	7 200 (496)	0.24 (0.36)
3/4 (19.0)	0.75 (19.0)	1.00 (25.4)	3.50 (8.89)	4.55 (11.6)		200 (93)	1250 (86.1)	5 000 (344)	0.36 (0.54)
1 (25.4) ^①	1.00 (25.4)	1.32 (33.5)	5.50 (14.0)	7.15 (18.2)		150 (65)	1000 (68.9)	4 000 (275)	1.1 (1.6)

Pressure-temperature ratings may be limited by the end connections.

① Constructed with two stainless steel braids and no fiber braid reinforcement.

Pressure-Temperature Ratings

Nominal Hose Size, in.	1/4	3/8	1/2	3/4	1
Temperature, °F (°C)	Working Pressure, psig (bar)				
0 -65 (-53) to 100 (37)	3500 (241)	3000 (206)	1800 (124)	1250 (86.1)	1000 (68.9)
200 (93)	3500 (241)	2345 (161)	1800 (124)	1135 (78.2)	1000 (68.9)
300 (148)	3460 (238)	1965 (135)	1790 (123)	1010 (69.5)	895 (61.6)
400 (204)	3265 (224)	1810 (124)	1665 (114)	900 (62.0)	895 (61.6)
450 (230)	3205 (220)	1675 (115)	1665 (114)	900 (62.0)	895 (61.6)

Coreflex X Series PTFE Hose

Testing

Every Swagelok X series hose assembly is pressure tested with water at room temperature for 30 seconds to a requirement of no detectable leakage. Testing is performed at 1000 psig (69 bar), or 225 psig (15.5 bar) if an end connection is rated below 1000 psig (69 bar).

Cleaning and Packaging

Every Swagelok X series hose component is cleaned in accordance with Swagelok *Standard Cleaning and Packaging (SC-10)*, MS-06-62.

Ordering Information

Custom Hose Assemblies

Build a hose assembly ordering number by combining the designators in the sequence shown below.



Typical Ordering Number

1 2 3 4 4 5 6 5 6
SS - XT 8 TA 8 KC 16 - 28 MB or **71 CM - MB**
in. cm

1 Material

End Connections

SS = 316 stainless steel

2 Hose

XT = X series PTFE hose

XC = X series carbon black-filled PTFE hose (Ω)

3 Nominal Hose Size, in.

4 = 1/4

6 = 3/8

8 = 1/2

12 = 3/4

16 = 1

4 End Connections

See **End Connection Designator** column in tables on pages 52 to 60.

Add designators in reverse alphanumeric order.

5 Overall Length

Inches or centimeters, in whole numbers. Include **CM** as shown for centimeter lengths.

Typical maximum one-piece hose length:

■ 900 in. or 2286 cm for 1/4 through 1/2 in. hose

■ 600 in. or 1524 cm for 3/4 and 1 in. hose.

Longer assemblies may be spliced; specify splices under **Options**. See page 4 for more information about splices.

6 Options

For multiple options, add designators in alphanumeric order with a dash between each designator. For hose lengths specified in centimeters, insert a dash as shown prior to the first option designator.

A = Armor guard

F = Fire jacket

G6 = Spiral guard, black

G7 = Spiral guard, blue

G8 = Spiral guard, yellow

Splices

SP1 = 1 splice

SP2 = 2 splices

Mat Tags

MA = Gray

MO = Orange

MB = Blue

MP = Purple

MC = Brown

MR = Red

MG = Green

MW = White

MK = Black

MY = Yellow

MN = Pink

Other Tags

T = Lanyard tag

T2 = Two lanyard tags

Specify text for tags. see **Hose Tag Text** table, page 84.

See page 83 for detailed descriptions of options.

Coreflex S Series PTFE Hose

Features

- Highly flexible, silicone-covered PTFE hose.
- Smooth-bore PTFE core.
- Size range of 1/8 through 1 in. and working pressures up to 3500 psig (241 bar).
- Fiber braid bonded to the core with a patent-pending process supports core to resist kinking.
- 304 stainless steel braid protects the core from abrasion and enhances hose pressure rating (M).
- Silicone cover provides smooth, noncontaminating, easy-to-clean surface and insulation from internal system fluid temperature extremes.
- PTFE material complies with FDA regulation 21CFR Part 177.1550, USP <88> Class VI (121°C), and 3-A.
- Optional carbon black-filled PTFE core is available for applications that require static dissipation (Ω).
- Commonly used where flexibility and chemical compatibility are desired.
- Custom hose lengths and end connections available.
- Options include hose covers and hose tags. See page 83 for details.

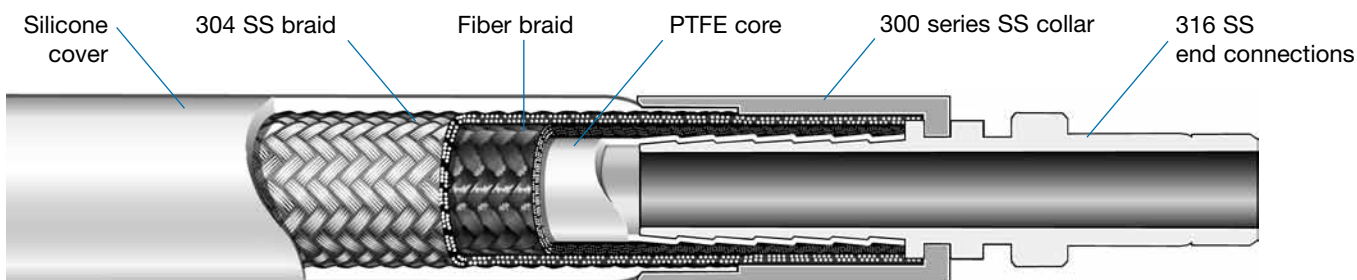

Technical Data

Nominal Hose Size in. (mm)	Inside Diameter in. (mm)	Outside Diameter in. (mm)	Minimum Inside Bend Radius in. (cm)		Temperature Range °F (°C)	Vacuum (28.5 in.Hg [96.5 kPa]) Rated to ... °F (°C)	Working Pressure at 70°F (20°C) psig (bar)	Burst Pressure at 70°F (20°C) psig (bar)	Bulk Hose Weight lb/ft (kg/m)
			Static	Dynamic					
1/8 (3.2) ^①	0.125 (3.2)	0.42 (10.7)	1.50 (3.81)	3.75 (9.52)	-65 to 450 (-53 to 230)	450 (230)	3000 (206)	12 000 (826)	0.09 (0.13)
1/4 (6.4)	0.25 (6.4)	0.55 (14.0)	1.25 (3.18)	4.20 (10.7)		450 (230)	3500 (241)	14 000 (964)	0.19 (0.28)
3/8 (9.6)	0.38 (9.6)	0.71 (18.0)	1.75 (4.44)	4.40 (11.2)		450 (230)	3000 (206)	12 000 (826)	0.25 (0.37)
1/2 (12.7)	0.50 (12.7)	0.86 (21.8)	2.50 (6.35)	4.55 (11.6)		450 (230)	1800 (124)	7 200 (496)	0.34 (0.51)
3/4 (19.0)	0.75 (19.0)	1.12 (28.4)	3.50 (8.89)	6.38 (16.2)		200 (93)	1250 (86.1)	5 000 (344)	0.47 (0.70)
1 (25.4) ^②	1.00 (25.4)	1.55 (39.4)	5.50 (14.0)	7.15 (18.2)		150 (65)	1000 (68.9)	4 000 (275)	1.8 (2.7)

Pressure-temperature ratings may be limited by the end connections.

① Constructed with no fiber braid reinforcement.

② Constructed with two stainless steel braids and no fiber braid reinforcement.

Pressure-Temperature Ratings

Nominal Hose Size, in.	1/8	1/4	3/8	1/2	3/4	1
Temperature, °F (°C)	Working Pressure, psig (bar)					
0 -65 (-53) to 100 (37)	3000 (206)	3500 (241)	3000 (206)	1800 (124)	1250 (86.1)	1000 (68.9)
200 (93)	3000 (206)	3500 (241)	2650 (182)	1800 (124)	1250 (86.1)	1000 (68.9)
300 (148)	2610 (179)	3435 (236)	2510 (172)	1800 (124)	1250 (86.1)	1000 (68.9)
400 (204)	2550 (175)	3320 (228)	2495 (171)	1800 (124)	1250 (86.1)	1000 (68.9)
450 (230)	2035 (140)	3320 (228)	2320 (159)	1800 (124)	1100 (75.7)	1000 (68.9)

Coreflex S Series PTFE Hose

Testing

Every Swagelok S series hose assembly is pressure tested with water at room temperature for 30 seconds to a requirement of no detectable leakage.

Testing is performed at 1000 psig (69 bar), or 225 psig (15.5 bar) if an end connection is rated below 1000 psig (69 bar).

Cleaning and Packaging

Every Swagelok S series hose component is cleaned in accordance with Swagelok *Standard Cleaning and Packaging (SC-10)*, MS-06-62.

Ordering Information

Custom Hose Assemblies

Build a hose assembly ordering number by combining the designators in the sequence shown below.



Typical Ordering Number

1 2 3 4 4 5 6 5 6
SS - ST 8 TA 8 KC 16 - 28 PB or **71 CM - PB**
in. cm

1 Material

End Connections

SS = 316 stainless steel

2 Hose

ST = S series PTFE hose with silicone-cover

SC = S series carbon black-filled PTFE hose with silicone cover (Ω) (not available in 1/8 in. hose size)

3 Nominal Hose Size, in.

2 = 1/8 (ST series only)
 4 = 1/4
 6 = 3/8
 8 = 1/2
 12 = 3/4
 16 = 1

4 End Connections

See **End Connection Designator** column in tables on pages 52 to 60.

Add designators in reverse alphanumeric order.

5 Overall Length

Inches or centimeters, in whole numbers. Include **CM** as shown for centimeter lengths.

Typical maximum one-piece hose length:

- 900 in. or 2286 cm for 1/4 through 1/2 in. hose
- 600 in. or 1524 cm for 3/4 and 1 in. hose.

Longer assemblies may be spliced; specify splices under **Options**. See page 4 for more information about splices.

6 Options

For multiple options, add designators in alphanumeric order with a dash between each designator. For hose lengths specified in centimeters, insert a dash as shown prior to the first option designator.

- A = Armor guard
- F = Fire jacket
- G6 = Spiral guard, black
- G7 = Spiral guard, blue
- G8 = Spiral guard, yellow

Splices

- SP1 = 1 splice
- SP2 = 2 splices

Mat Tags

- MA = Gray MO = Orange
- MB = Blue MP = Purple
- MC = Brown MR = Red
- MG = Green MW = White
- MK = Black MY = Yellow
- MN = Pink

Perma Tags (not available in 1/8 in. hose size)

- PA = Gray PO = Orange
- PB = Blue PP = Purple
- PC = Brown PR = Red
- PG = Green PW = White
- PK = Black PY = Yellow
- PN = Pink

Other Tags

- T = Lanyard tag
- T2 = Two lanyard tags

Specify text for tags. see **Hose Tag Text** table, page 84.

See page 83 for detailed descriptions of options.

Coreflex C Series PTFE Hose

Features

- Low-weight, highly flexible PTFE hose.
- Convoluted bore PTFE core.
- Size range of 1/2 through 2 in. and working pressures up to 1500 psig (103 bar).
- 300 series stainless steel braid ensures hose pressure containment and protects the core from abrasion (M).
- Optional silicone cover provides smooth, noncontaminating, easy-to-clean surface and insulation from internal system fluid temperature extremes.
- PTFE material complies with FDA regulation 21CFR Part 177.1550, USP <88> Class VI, and 3-A.
- Optional carbon black-filled PTFE core is available for applications that require static dissipation (Ω).
- Commonly used where high flexibility and chemical compatibility are desired.
- Custom hose lengths and end connections available.
- Options include hose covers and hose tags. See page 83 for details.

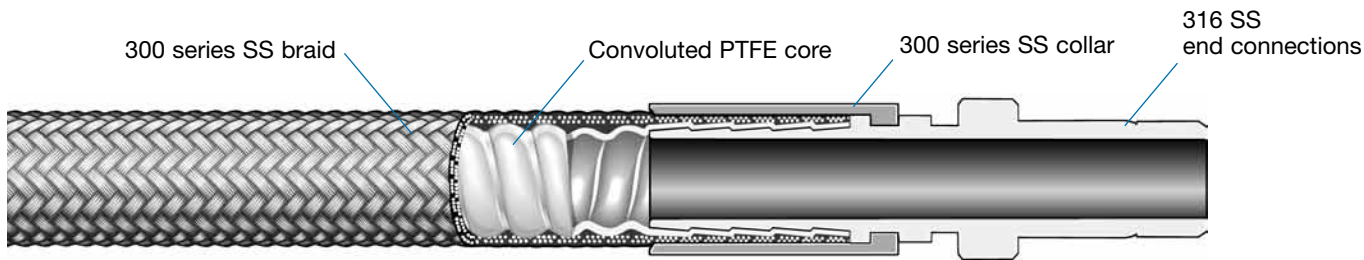

Technical Data

Nominal Hose Size in. (mm)	Inside Diameter in. (mm)	Outside Diameter in. (mm)	Minimum Inside Bend Radius in. (cm)		Temperature Range °F (°C)	Vacuum (28.5 in.Hg [96.5 kPa]) Rated to ... °F (°C)	Working Pressure at 70°F (20°C) psig (bar)	Burst Pressure at 70°F (20°C) psig (bar)	Bulk Hose Weight lb/ft (kg/m)
			Static	Dynamic					
Without Silicone Cover									
1/2 (12.7)	0.50 (12.7)	0.76 (19.3)	2.50 (6.35)	3.75 (9.52)	-65 to 450 (-53 to 230)	450 (230)	1500 (103)	6000 (413)	0.20 (0.30)
3/4 (19.0)	0.75 (19.0)	1.00 (25.4)	3.00 (7.62)	3.90 (9.91)		450 (230)	1100 (75.7)	4400 (303)	0.28 (0.42)
1 (25.4)	1.00 (25.4)	1.32 (33.5)	5.50 (14.0)	7.15 (18.2)		200 (93)	750 (51.6)	3000 (206)	0.47 (0.70)
1 1/2 (38.1)	1.50 (38.1)	2.03 (51.6)	6.00 (15.2)	7.80 (19.8)	-20 to 340 (-28 to 171)	150 (65)	700 (48.2)	2800 (192)	0.83 (1.2)
2 (50.8)	2.00 (50.8)	2.46 (62.5)	7.50 (19.0)	9.75 (24.8)		—	525 (36.1)	2100 (144)	1.02 (1.5)
With Silicone Cover									
1/2 (12.7)	0.50 (12.7)	0.88 (22.4)	2.50 (6.35)	3.75 (9.52)	-65 to 450 (-53 to 230)	450 (230)	1500 (103)	6000 (413)	0.28 (0.42)
3/4 (19.0)	0.75 (19.0)	1.12 (28.4)	3.00 (7.62)	3.90 (9.91)		450 (230)	1100 (75.7)	4400 (303)	0.40 (0.60)
1 (25.4)	1.00 (25.4)	1.47 (37.3)	5.50 (14.0)	7.15 (18.2)		200 (93)	750 (51.6)	3000 (206)	0.72 (1.1)

Pressure-temperature ratings may be limited by the end connections.

Pressure-Temperature Ratings

Hose Style	Without Silicone Cover					With Silicone Cover		
	1/2 ^①	3/4 ^①	1 ^①	1 1/2	2	1/2	3/4	1
Temperature, °F (°C)	Working Pressure, psig (bar)							
-65 (-53)	1500 (103)	1100 (75.7)	750 (51.6)	—	—	1500 (103)	1100 (75.7)	750 (51.6)
-20 (-28)	1500 (103)	1100 (75.7)	750 (51.6)	675 (46.5)	525 (36.1)	1500 (103)	1100 (75.7)	750 (51.6)
0 (-17) to 100 (37)	1500 (103)	1100 (75.7)	750 (51.6)	700 (48.2)	525 (36.1)	1500 (103)	1100 (75.7)	750 (51.6)
200 (93)	1500 (103)	1100 (75.7)	700 (48.2)	435 (29.9)	525 (36.1)	1500 (103)	1100 (75.7)	750 (51.6)
300 (148)	1500 (103)	1100 (75.7)	620 (42.7)	405 (27.9)	495 (34.1)	1500 (103)	1095 (75.4)	620 (42.7)
340 (171)	1500 (103)	1030 (70.9)	600 (41.3)	330 (22.7)	485 (33.4)	1500 (103)	1075 (74.0)	595 (40.9)
400 (204)	1500 (103)	960 (66.1)	565 (38.9)	—	—	1500 (103)	1050 (72.3)	555 (38.2)
450 (230)	1500 (103)	900 (62.0)	490 (33.7)	—	—	1485 (102)	925 (63.7)	405 (27.7)

① Hose with carbon black-filled PTFE core (CC series) is limited to -20 to 340°F (-28 to 171°C).

Coreflex N Series PTFE Hose

Features

- Thermally insulated, nonmetallic PTFE hose.
- Convoluted bore, carbon black-filled PTFE core for applications that require static dissipation (Ω).
- 3/8, 1/2, and 3/4 in. sizes and working pressures up to 1250 psig (86.1 bar).
- Internal insulating wrap eliminates need for external insulation in many applications.
- Aramid fiber braid aids pressure containment and maintains flexibility while reducing weight.
- PTFE material complies with FDA regulation 21CFR Part 177.1550 and USP <88> Class VI.
- Commonly used where flexibility, chemical compatibility, and a nonconductive braid are desired.
- Custom hose lengths and end connections available.
- Options include hose covers and hose tags. See page 83 for details.

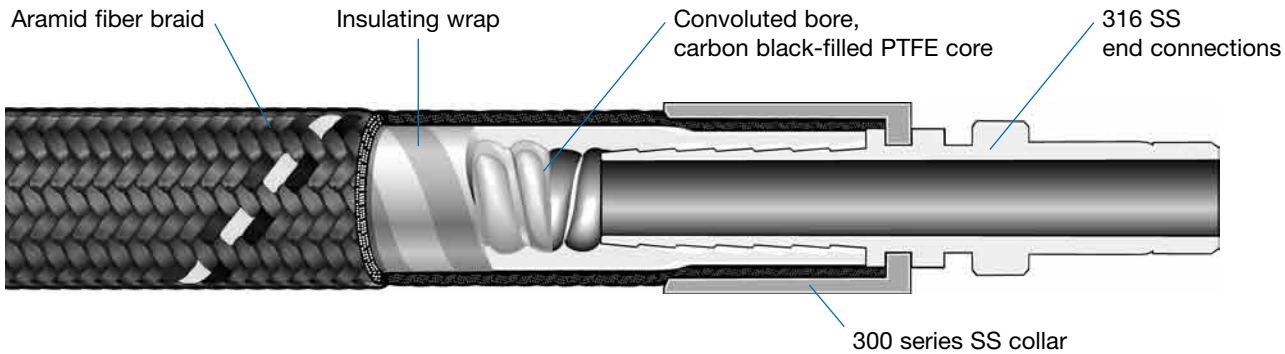

Technical Data

Nominal Hose Size in. (mm)	Inside Diameter in. (mm)	Outside Diameter in. (mm)	Minimum Inside Bend Radius in. (cm)		Temperature Range °F (°C)	Vacuum (28.5 in.Hg [96.5 kPa]) Rated to ... °F (°C)	Working Pressure at 70°F (20°C) psig (bar)	Burst Pressure at 70°F (20°C) psig (bar)	Bulk Hose Weight lb/ft (kg/m)
			Static	Dynamic					
3/8 (9.6)	0.41 (10.4)	0.73 (18.5)	2.50 (6.35)	4.00 (10.2)	-65 to 450 (-53 to 230)	450 (230)	1250 (86.1)	5000 (344)	0.12 (0.18)
1/2 (12.7)	0.53 (13.5)	0.86 (21.8)	3.50 (8.89)	5.25 (13.3)		400 (204)	750 (51.6)	3000 (206)	0.15 (0.22)
3/4 (19.0)	0.75 (19.0)	1.12 (28.4)	4.50 (11.4)	5.85 (14.9)		—	375 (25.8)	1500 (103)	0.19 (0.28)

Pressure-temperature ratings may be limited by the end connections.

Pressure-Temperature Ratings

Nominal Hose Size, in.	3/8	1/2	3/4
Temperature, °F (°C)	Working Pressure, psig (bar)		
-65 (-53)	1250 (86.1)	720 (49.6)	375 (25.8)
0 (-17) to 100 (37)	1250 (86.1)	750 (51.6)	375 (25.8)
200 (93)	500 (34.4)	340 (23.4)	275 (18.9)
300 (148)	365 (25.1)	235 (16.1)	165 (11.3)
400 (204)	165 (11.3)	160 (11.0)	85.0 (5.8)
450 (230)	140 (9.6)	130 (8.9)	80.0 (5.5)

Coreflex W Series PTFE Hose

Features

- Thermally insulated PTFE hose.
- Smooth-bore, carbon black-filled PTFE core for applications that require static dissipation (Ω).
- 3/8, 1/2, and 3/4 in. sizes and working pressures up to 750 psig (51.6 bar).
- Fiber braid bonded to the core with a patent-pending process supports core to reduce kinking.
- Internal insulating wrap eliminates need for external insulation in many applications.
- 304 stainless steel braid ensures hose pressure containment and protects the core from abrasion (M).
- Silicone cover provides smooth, noncontaminating, easy-to-clean surface and insulation from internal system fluid temperature extremes; cover is available in black, blue, red, and white.
- PTFE material complies with FDA regulation 21CFR Part 177.1550 and USP <88> Class VI.
- Commonly used where flexibility, chemical compatibility, and exterior insulating (hot/cold) cover are desired.
- Custom hose lengths and end connections available.
- Options include hose covers and hose tags. See page 83 for details.

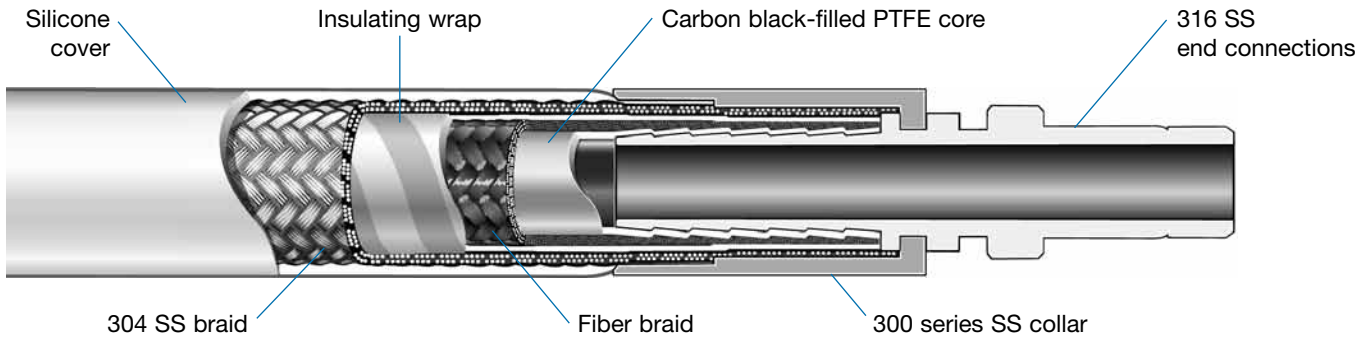

Technical Data

Nominal Hose Size in. (mm)	Inside Diameter in. (mm)	Outside Diameter in. (mm)	Minimum Inside Bend Radius in. (cm)		Temperature Range °F (°C)	Vacuum (28.5 in.Hg [96.5 kPa]) Rated to ... °F (°C)	Working Pressure at 70°F (20°C) psig (bar)	Burst Pressure at 70°F (20°C) psig (bar)	Bulk Hose Weight lb/ft (kg/m)
			Static	Dynamic					
3/8 (9.6)	0.35 (8.9)	0.75 (19.0)	2.75 (6.98)	4.40 (11.2)	-65 to 450 (-53 to 230)	450 (230)	750 (51.6)	3000 (206)	0.29 (0.43)
1/2 (12.7)	0.50 (12.7)	0.92 (23.4)	4.25 (10.8)	6.38 (16.2)		200 (93)	750 (51.6)	3000 (206)	0.35 (0.52)
3/4 (19.0)	0.75 (19.0)	1.19 (30.2)	6.75 (17.1)	8.00 (20.3)		—	500 (34.4)	2000 (137)	0.50 (0.74)

Pressure-temperature ratings may be limited by the end connections.

Pressure-Temperature Ratings

Nominal Hose Size, in.	3/8, 1/2	3/4
Temperature, °F (°C)	Working Pressure, psig (bar)	
-65 (-53) to 450 (230)	750 (51.6)	500 (34.4)

Coreflex W Series PTFE Hose

Testing

Every Swagelok W series hose assembly is pressure tested with water at room temperature for 30 seconds to a requirement of no detectable leakage.

Testing is performed at 500 psig (34.4 bar), or 225 psig (15.5 bar) if an end connection is rated below 500 psig (34.4 bar).

Cleaning and Packaging

Every Swagelok W series hose component is cleaned in accordance with Swagelok *Standard Cleaning and Packaging (SC-10)*, MS-06-62.

Ordering Information

Custom Hose Assemblies

Build a hose assembly ordering number by combining the designators in the sequence shown below.



Typical Ordering Number

2 3 4 4 5 6 7 or 5 6 7
SS - WC 8 TA 8 KC 16 - 28 - BL PG or **71 CM - BL PG**
1 in. cm

1 Material

End Connections

SS = 316 stainless steel

2 Hose

WC = W series carbon black-filled PTFE hose with silicone-cover and insulating wrap (Ω)

3 Nominal Hose Size, in.

6 = 3/8
8 = 1/2
12 = 3/4

4 End Connections

See **End Connection Designator** column in tables on pages 52 to 60.

Add designators in reverse alphanumeric order.

5 Overall Length

Inches or centimeters, in whole numbers. Include **CM** as shown for centimeter lengths.

Typical maximum one-piece hose length is 300 in. or 762 cm. Longer assemblies may be spliced; specify splices under **Options**. See page 4 for more information about splices.

6 Silicone Cover Color

BK = Black
BL = Blue
RD = Red
WH = White

7 Options

For multiple options, add designators in alphanumeric order with a dash between each designator.

A = Armor guard
F = Fire jacket
G6 = Spiral guard, black
G7 = Spiral guard, blue
G8 = Spiral guard, yellow

Splices

SP1 = 1 splice
SP2 = 2 splices

Mat Tags

MA = Gray	MO = Orange
MB = Blue	MP = Purple
MC = Brown	MR = Red
MG = Green	MW = White
MK = Black	MY = Yellow
MN = Pink	

Perma Tags

PA = Gray	PO = Orange
PB = Blue	PP = Purple
PC = Brown	PR = Red
PG = Green	PW = White
PK = Black	PY = Yellow
PN = Pink	

Other Tags

T = Lanyard tag
T2 = Two lanyard tags

Specify text for tags. see **Hose Tag Text** table, page 84.

See page 83 for detailed descriptions of options.

Coreflex F Series PTFE Hose

Features

- Nonmetallic PTFE hose.
- Smooth-bore PTFE core.
- Size range of 1/4 through 3/4 in. and working pressures up to 800 psig (55.1 bar).
- Fiber braid bonded to the core with a patent-pending process supports core to resist kinking.
- PTFE material complies with FDA regulation 21CFR Part 177.1550 and USP <88> Class VI.
- Optional carbon black-filled PTFE core is available for applications that require static dissipation (Ω).
- Commonly used where flexibility, chemical compatibility, and a nonconductive braid are desired.
- Custom hose lengths and end connections available.
- Options include hose covers and hose tags. See page 83 for details.

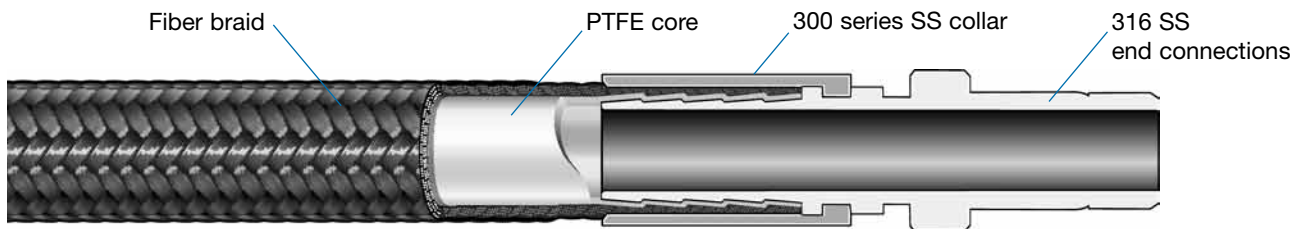

Technical Data

Nominal Hose Size in. (mm)	Inside Diameter in. (mm)	Outside Diameter in. (mm)	Minimum Inside Bend Radius in. (cm)		Temperature Range °F (°C)	Working Pressure at 70°F (20°C) psig (bar)	Burst Pressure at 70°F (20°C) psig (bar)	Bulk Hose Weight lb/ft (kg/m)
			Static	Dynamic				
1/4 (6.4)	0.25 (6.4)	0.41 (10.4)	2.75 (6.99)	5.50 (14.0)	-65 to 450 (-53 to 230)	800 (55.1)	3200 (220)	0.06 (0.09)
3/8 (9.6)	0.38 (9.6)	0.55 (14.0)	3.25 (8.26)	5.20 (13.2)		650 (44.7)	2600 (179)	0.09 (0.13)
1/2 (12.7)	0.50 (12.7)	0.70 (17.8)	5.25 (13.3)	7.88 (20.0)		450 (31.0)	1800 (124)	0.13 (0.19)
3/4 (19.0)	0.75 (19.0)	0.94 (23.9)	6.50 (16.5)	8.45 (21.5)		325 (22.4)	1300 (89.6)	0.18 (0.27)

Pressure-temperature ratings may be limited by the end connections.

Pressure-Temperature Ratings

Nominal Hose Size, in.	1/4	3/8	1/2	3/4
Temperature, °F (°C)	Working Pressure, psig (bar)			
-65 (-53)	455 (31.3)	480 (33.0)	450 (31.0)	325 (22.3)
0 (-17) to 100 (37)	800 (55.1)	650 (44.7)	450 (31.0)	325 (22.3)
200 (93)	700 (48.2)	490 (33.7)	450 (31.0)	185 (12.7)
300 (148)	330 (22.7)	490 (33.7)	315 (21.7)	175 (12.0)
400 (204)	160 (11.0)	170 (11.7)	310 (21.3)	175 (12.0)
450 (230)	160 (11.0)	170 (11.7)	295 (20.3)	160 (11.0)

Coreflex F Series PTFE Hose

Testing

Every Swagelok F series hose assembly is pressure tested with water at room temperature for 30 seconds to a requirement of no detectable leakage. Testing is performed at 500 psig (34.4 bar), or 225 psig (15.5 bar) if an end connection is rated below 500 psig (34.4 bar).

Cleaning and Packaging

Every Swagelok F series hose component is cleaned in accordance with Swagelok *Standard Cleaning and Packaging (SC-10)*, MS-06-62.

Ordering Information

Custom Hose Assemblies

Build a hose assembly ordering number by combining the designators in the sequence shown below.



Typical Ordering Number

1 2 3 4 4 5 6 5 6
SS - FT 8 TA 8 KC 16 - 28 MB or **71 CM - MB**
in. cm

1 Material

End Connections

SS = 316 stainless steel

2 Hose

FT = F series PTFE hose

FC = F series carbon black-filled PTFE hose (Ω)

3 Nominal Hose Size, in.

4 = 1/4

6 = 3/8

8 = 1/2

12 = 3/4

4 End Connections

See **End Connection Designator** column in tables on pages 52 to 60.

Add designators in reverse alphanumeric order.

5 Overall Length

Inches or centimeters, in whole numbers. Include **CM** as shown for centimeter lengths.

Typical maximum one-piece hose length:

■ 900 in. or 2286 cm for 1/4 through 1/2 in. hose

■ 600 in. or 1524 cm for 3/4 in. hose.

Longer assemblies may be spliced; specify splices under **Options**. See page 4 for more information about splices.

6 Options

For multiple options, add designators in alphanumeric order with a dash between each designator. For hose lengths specified in centimeters, insert a dash as shown prior to the first option designator.

A = Armor guard

F = Fire jacket

G6 = Spiral guard, black

G7 = Spiral guard, blue

G8 = Spiral guard, yellow

Splices

SP1 = 1 splice

SP2 = 2 splices

Mat Tags

MA = Gray

MO = Orange

MB = Blue

MP = Purple

MC = Brown

MR = Red

MG = Green

MW = White

MK = Black

MY = Yellow

MN = Pink

Other Tags

T = Lanyard tag

T2 = Two lanyard tags

Specify text for tags. see **Hose Tag Text** table, page 84.

See page 83 for detailed descriptions of options.

Coreflex U Series PFA Hose

Features

- Highly flexible PFA hose.
- Smooth-bore PFA core.
- Size range of 1/2 through 2 in. and working pressures up to 300 psig (20.6 bar).
- 302 stainless steel reinforcement ensures hose pressure containment and supports core to resist kinking (M).
- Silicone cover provides a smooth, noncontaminating, easy-to-clean surface and reduces internal system fluid temperature transfer.
- Hose layers are encapsulated together without adhesives or cements with a patent-pending process, providing high flexibility and outstanding kink resistance.
- PFA material complies with FDA regulation 21CFR Part 177.1550, USP <87, 88> Class VI (121°C), and 3-A.
- Optional carbon black-filled PFA core is available for applications that require static dissipation (Ω).
- Commonly used where high flexibility, chemical compatibility, and a smooth exterior cover are desired.
- Custom hose lengths and end connections available.
- Options include hose covers and hose tags. See page 83 for details.

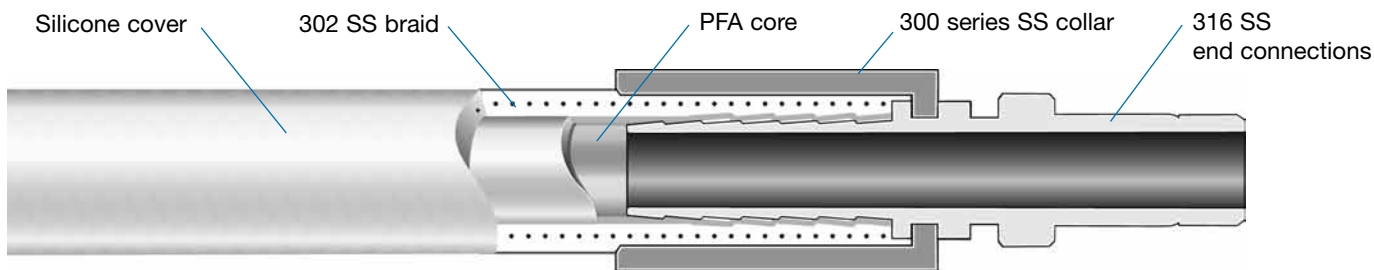

Technical Data

Nominal Hose Size in. (mm)	Inside Diameter in. (mm)	Outside Diameter in. (mm)	Minimum Inside Bend Radius in. (cm)		Temperature Range °F (°C)	Vacuum (28.5 in.Hg [96.5 kPa]) Rated to ... °F (°C)	Working Pressure at 70°F (20°C) psig (bar)	Burst Pressure at 70°F (20°C) psig (bar)	Bulk Hose Weight lb/ft (kg/m)
			Static	Dynamic					
1/2 (12.7)	0.50 (12.7)	0.80 (20.3)	1.50 (3.81)	4.50 (11.4)	-65 to 400 (-53 to 204)	400 (204)	300 (20.6)	1200 (82.6)	0.20 (0.30)
3/4 (19.0)	0.75 (19.0)	1.12 (28.6)	2.50 (6.35)	6.50 (16.5)		400 (204)	300 (20.6)	1200 (82.6)	0.38 (0.57)
1 (25.4)	1.00 (25.4)	1.46 (37.0)	4.00 (10.2)	5.20 (13.2)		250 (121)	250 (17.2)	1000 (68.9)	0.63 (0.94)
1 1/2 (38.1)	1.50 (38.1)	2.01 (51.1)	7.00 (17.8)	9.10 (23.1)		250 (121)	200 (13.7)	800 (55.1)	0.88 (1.3)
2 (50.8)	2.00 (50.8)	2.51 (63.8)	7.00 (17.8)	9.10 (23.1)		150 (65)	150 (10.3)	600 (41.3)	1.3 (1.9)

Pressure-temperature ratings may be limited by the end connections.

Pressure-Temperature Ratings

Nominal Hose Size, in.	1/2	3/4	1	1 1/2	2
Temperature, °F (°C)	Working Pressure, psig (bar)				
-65 (-53)	200 (13.7)	115 (7.9)	250 (17.2)	200 (13.7)	150 (10.3)
0 (-17) to 100 (37)	300 (20.6)	300 (20.6)	250 (17.2)	200 (13.7)	150 (10.3)
200 (93)	280 (19.2)	300 (20.6)	250 (17.2)	200 (13.7)	150 (10.3)
300 (148)	210 (14.4)	270 (18.6)	230 (15.8)	200 (13.7)	150 (10.3)
400 (204)	160 (11.0)	195 (13.4)	175 (12.0)	200 (13.7)	150 (10.3)

Coreflex U Series PFA Hose

Testing

Every Swagelok U series hose assembly is pressure tested with water at room temperature for 30 seconds to a requirement of no detectable leakage. Testing is performed at 225 psig (15.5 bar).

Cleaning and Packaging

Every Swagelok U series hose component is cleaned in accordance with Swagelok *Standard Cleaning and Packaging (SC-10)*, MS-06-62.

Ordering Information

Custom Hose Assemblies

Build a hose assembly ordering number by combining the designators in the sequence shown below.



Typical Ordering Number

1 2 3 4 4 5 6 5 6
SS - UT 8 TA 8 KC 16 - 28 PB or **71 CM - PB**
in. cm

1 Material

End Connections

SS = 316 stainless steel

2 Hose

UT = U series PFA hose with silicone cover

UC = U series carbon black-filled PFA hose with silicone cover (Ω)

3 Nominal Hose Size, in.

8 = 1/2
 12 = 3/4
 16 = 1
 24 = 1 1/2
 32 = 2

4 End Connections

See **End Connection Designator** column in tables on pages 52 to 60.

Add designators in reverse alphanumeric order.

5 Overall Length

Inches or centimeters, in whole numbers. Include **CM** as shown for centimeter lengths.

Typical maximum one-piece hose length:

- 900 in. or 2286 cm for 1/2 in. hose
- 600 in. or 1524 cm for 3/4 and 1 in. hose
- 300 in. or 762 cm for 1 1/2 and 2 in. hose.

Longer assemblies may be spliced; specify splices under **Options**. See page 4 for more information about splices.

6 Options

For multiple options, add designators in alphanumeric order with a dash between each designator. For hose lengths specified in centimeters, insert a dash as shown prior to the first option designator.

A = Armor guard

F = Fire jacket

G6 = Spiral guard, black

G7 = Spiral guard, blue

G8 = Spiral guard, yellow

Splices

SP1 = 1 splice

SP2 = 2 splices

Mat Tags

MA = Gray

MB = Blue

MC = Brown

MG = Green

MK = Black

MN = Pink

MO = Orange

MP = Purple

MR = Red

MW = White

MY = Yellow

Perma Tags

PA = Gray

PB = Blue

PC = Brown

PG = Green

PK = Black

PN = Pink

PO = Orange

PP = Purple

PR = Red

PW = White

PY = Yellow

Other Tags

T = Lanyard tag

T2 = Two lanyard tags

Specify text for tags. See **Hose Tag Text** table, page 84.

See page 83 for detailed descriptions of options.

Coreflex Series Hose—End Connections

End Connections

Swagelok Tube Adapters

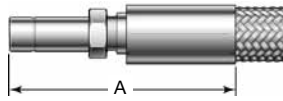

1 in. / 25 mm and Under

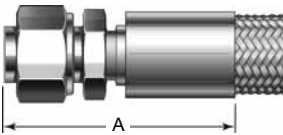

Over 1 in. / 25 mm

Tube Adapter Size	Nominal Hose Size Designator	End Connection Designator	Dimensions			Pressure Rating psig (bar)
			A Max	Minimum Inside Diameter	Maximum Outside Dimension	
Dimensions, in. (mm)						
1/8	2	TA2	1.86 (47.2)	0.070 (1.7)	0.55 (14.0)	Determined by hose
1/4	4	TA4	1.96 (49.8)	0.16 (4.0)	0.59 (15.0)	
3/8	6	TA6	2.42 (61.5)	0.26 (6.6)	0.82 (20.8)	
1/2	8	TA8	2.91 (73.9)	0.34 (8.6)	1.04 (26.4)	
3/4	12	TA12	3.53 (89.7)	0.54 (13.7)	1.35 (34.3)	
1	16	TA16	3.78 (96.0)	0.78 (19.8)	1.75 (44.5)	
1 1/2 ^①	24	TA24	5.22 (133)	1.24 (31.4)	2.20 (55.9)	
2 ^①	32	TA32	6.82 (173)	1.68 (42.6)	2.74 (69.6)	
Dimensions, mm (in.)						
3	2	TM3	47.8 (1.88)	1.7 (0.070)	14.0 (0.55)	Determined by hose
6	4	TM6	50.3 (1.98)	4.0 (0.16)	15.0 (0.59)	
10	6	TM10	62.0 (2.44)	6.6 (0.26)	20.8 (0.82)	
12	8	TM12	74.4 (2.93)	8.6 (0.34)	23.1 (0.91)	
18	12	TM18	90.2 (3.55)	13.7 (0.54)	34.3 (1.35)	
25	16	TM25	96.5 (3.80)	19.8 (0.78)	44.5 (1.75)	
38 ^①	24	TM38	133 (5.24)	31.4 (1.24)	55.9 (2.20)	
50 ^①	32	TM50	173 (6.81)	42.6 (1.68)	69.6 (2.74)	

① Furnished with nut and preswaged ferrules.

Swagelok Tube Fittings

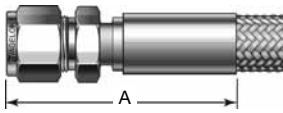

Tube Fitting Size	Nominal Hose Size Designator	End Connection Designator	Dimensions			Pressure Rating psig (bar)
			A Max	Minimum Inside Diameter	Maximum Outside Dimension	
Dimensions, in. (mm)						
1/8	2	SL2	1.88 (47.8)	0.070 (1.7)	0.55 (14.0)	Determined by hose
1/4	4	SL4	2.02 (51.3)	0.16 (4.0)	0.59 (15.0)	
3/8	6	SL6	2.48 (63.0)	0.26 (6.6)	0.82 (20.8)	
1/2	8	SL8	2.81 (71.4)	0.34 (8.6)	1.04 (26.4)	
3/4	12	SL12	3.44 (87.4)	0.54 (13.7)	1.35 (34.3)	
1	16	SL16	3.61 (91.7)	0.78 (19.8)	1.75 (44.5)	
1 1/2	24	SL24	5.12 (130)	1.24 (31.4)	2.46 (62.5)	
2	32	SL32	6.72 (171)	1.68 (42.6)	3.18 (80.8)	
Dimensions, mm (in.)						
3	2	SM3	48.5 (1.91)	1.7 (0.070)	14.0 (0.55)	Determined by hose
6	4	SM6	51.3 (2.02)	4.0 (0.16)	16.3 (0.64)	
10	6	SM10	64.5 (2.54)	6.6 (0.26)	20.8 (0.82)	
12	8	SM12	71.9 (2.83)	8.6 (0.34)	26.4 (1.04)	
18	12	SM18	78.0 (3.07)	13.7 (0.54)	34.3 (1.35)	
25	16	SM25	91.7 (3.61)	19.8 (0.78)	44.5 (1.75)	
38	24	SM38	133 (5.24)	31.4 (1.24)	63.5 (2.50)	
50	32	SM50	169 (6.65)	42.6 (1.68)	80.8 (3.18)	

Coreflex Series Hose—End Connections

Female Pipe Threads, NPT

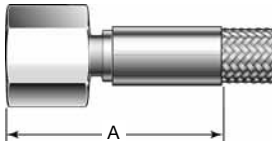

NPT Size in.	Nominal Hose Size Designator	End Connection Designator	Dimensions, in. (mm)			Pressure Rating psig (bar)
			A Max	Minimum Inside Diameter	Maximum Outside Dimension	
1/8	2	PF2	1.76 (44.7)	0.070 (1.7)	0.65 (16.5)	Determined by hose
1/4	4	PF4	1.85 (47.0)	0.16 (4.0)	0.87 (22.1)	
3/8	6	PF6	2.31 (58.7)	0.26 (6.6)	1.01 (25.7)	
1/2	8	PF8	2.66 (67.6)	0.34 (8.6)	1.30 (33.0)	
3/4	12	PF12	3.32 (84.3)	0.54 (13.7)	1.52 (38.6)	
1	16	PF16	3.44 (87.4)	0.78 (19.8)	1.88 (47.8)	
1 1/2	24	PF24	4.19 (106)	1.24 (31.4)	2.75 (69.9)	
2	32	PF32	4.88 (124)	1.68 (42.6)	3.18 (80.8)	

Female Pipe Threads, NPT, with JIC (AN) 37° Union

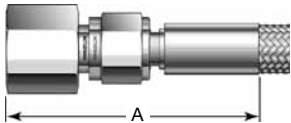

NPT with JIC Union Size in.	Nominal Hose Size Designator	End Connection Designator	Dimensions, in. (mm)			Pressure Rating psig (bar)
			A Max	Minimum Inside Diameter	Maximum Outside Dimension	
1/8	2	FU2	2.38 (60.5)	0.070 (1.7)	0.65 (16.5)	Determined by hose
1/4	4	FU4	2.61 (66.3)	0.16 (4.0)	0.87 (22.1)	
3/8	6	FU6	3.07 (78.0)	0.26 (6.6)	1.01 (25.7)	
1/2	8	FU8	3.59 (91.2)	0.34 (8.6)	1.23 (31.2)	
3/4	12	FU12	4.47 (114)	0.54 (13.7)	1.52 (38.6)	
1	16	FU16	4.77 (121)	0.78 (19.8)	2.02 (51.3)	
1 1/2	24	FU24	6.12 (155)	1.24 (31.4)	2.75 (69.9)	
2	32	FU32	7.05 (179)	1.68 (42.6)	3.46 (87.9)	

Male Pipe Threads, NPT

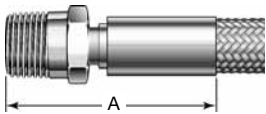

NPT Size in.	Nominal Hose Size Designator	End Connection Designator	Dimensions, in. (mm)			Pressure Rating psig (bar)
			A Max	Minimum Inside Diameter	Maximum Outside Dimension	
1/8	2	PM2	1.70 (43.2)	0.077 (1.9)	0.55 (14.0)	Determined by hose
1/4	4	PM4	1.91 (48.5)	0.19 (4.8)	0.65 (16.5)	
3/8	6	PM6	2.31 (58.7)	0.28 (7.1)	0.82 (20.8)	
1/2	8	PM8	2.72 (69.1)	0.37 (9.3)	1.04 (26.4)	
3/4	12	PM12	3.26 (82.8)	0.63 (16.0)	1.35 (34.3)	
1	16	PM16	3.45 (87.6)	0.87 (22.0)	1.75 (44.5)	
1 1/2	24	PM24	4.24 (108)	1.36 (34.5)	2.31 (58.7)	
2	32	PM32	5.12 (130)	1.84 (46.7)	2.89 (73.4)	

Male Pipe Threads, NPT, with JIC (AN) 37° Union

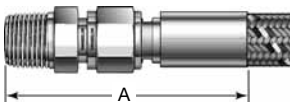

NPT with JIC Union Size in.	Nominal Hose Size Designator	End Connection Designator	Dimensions, in. (mm)			Pressure Rating psig (bar)
			A Max	Minimum Inside Diameter	Maximum Outside Dimension	
1/8	2	MU2	2.37 (60.2)	0.070 (1.7)	0.55 (14.0)	Determined by hose
1/4	4	MU4	2.70 (68.6)	0.16 (4.0)	0.65 (16.5)	
3/8	6	MU6	3.19 (81.0)	0.26 (6.6)	0.82 (20.8)	
1/2	8	MU8	3.71 (94.2)	0.34 (8.6)	1.04 (26.4)	
3/4	12	MU12	4.52 (115)	0.54 (13.7)	1.45 (36.8)	
1	16	MU16	4.75 (121)	0.78 (19.8)	1.75 (44.5)	
1 1/2	24	MU24	5.88 (149)	1.24 (31.4)	2.60 (66.0)	
2	32	MU32	7.08 (180)	1.68 (42.6)	3.32 (84.3)	

See next page for more end connections.

Coreflex Series Hose—End Connections

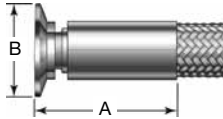
Sanitary Kwik-Clamps^①

① 316L SS material with a 15 $\mu\text{in.}$ (0.38 μm) R_a max surface finish prior to crimp.

Kwik-Clamp Size in.	Nominal Hose Size Designator	End Connection Designator		Dimensions, in. (mm)			Pressure Rating psig (bar)
		Standard Surface	Electro-polished	A Max	Minimum Inside Diameter	B, Flange Outside Diameter ^②	
1/2	4	KC8	KE8	1.60 (40.6)	0.16 (4.0)	0.98 (25.0)	1500 (103)
	6	KC8	KE8	1.97 (50.0)	0.26 (6.6)		
	8	KC8	KE8	2.32 (58.9)	0.34 (8.6)		
3/4	6	KC12	KE12	1.97 (50.0)	0.26 (6.6)	0.98 (25.0) ^③	1500 (103)
	8	KC12	KE12	2.20 (55.9)	0.34 (8.6)		
	12	KC12	KE12	2.48 (63.0)	0.54 (13.7)		
1	8	KC16	KE16	2.16 (54.9)	0.34 (8.6)	1.98 (50.3)	500 (34.4)
	12	KC16	KE16	2.70 (68.6)	0.54 (13.7)		
	16	KC16	KE16	2.76 (70.1)	0.78 (19.8)		
1 1/2	8	KC24	KE24	2.17 (55.1)	0.34 (8.6)	1.98 (50.3)	500 (34.4)
	12	KC24	KE24	2.70 (68.6)	0.54 (13.7)		
	16	KC24	KE24	2.60 (66.0)	0.78 (19.8)		
	24	KC24	KE24	3.31 (84.1)	1.24 (31.4)		
	32	KC24	KE24	4.03 (102)	1.68 (42.6)		
2	16	KC32	KE32	2.60 (66.0)	0.78 (19.8)	2.52 (64.0)	450 (31.0)
	24	KC32	KE32	3.21 (81.5)	1.24 (31.4)		
	32	KC32	KE32	3.98 (101)	1.68 (42.6)		
2 1/2	24	KC40	KE40	3.32 (84.3)	1.24 (31.4)	3.05 (77.5)	400 (27.5)
	32	KC40	KE40	3.97 (101)	1.68 (42.6)		

② The B dimension is also the maximum outside dimension of the hose assembly.

③ Hose assembly maximum outside dimension is 1.33 in. (33.8 mm).

Sanitary Kwik-Clamp 90° Elbows

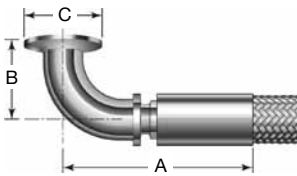

Kwik-Clamp Size in.	Nominal Hose Size Designator	End Connection Designator		Dimensions, in. (mm)				Pressure Rating psig (bar)
		Standard Surface	Electro-polished	A Max	B	Minimum Inside Diameter	C, Flange Outside Diameter ^①	
1/2	8	KR8	RE8	2.92 (74.2)	1.27 (32.3)	0.34 (8.6)	0.98 (25.0)	1500 (103)
3/4	12	KR12	RE12	3.45 (87.6)	1.63 (41.4)	0.54 (13.7)	0.98 (25.0) ^②	1500 (103)
1	16	KR16	RE16	4.10 (104)	2.02 (51.3)	0.78 (19.8)	1.98 (50.3)	500 (34.4)
1 1/2	24	KR24	RE24	5.90 (150)	2.77 (70.4)	1.24 (31.4)	1.98 (50.3)	500 (34.4)
2	32	KR32	RE32	7.56 (192)	3.51 (89.2)	1.68 (42.6)	2.52 (64.0)	450 (31.0)

① The C dimension is also the maximum outside dimension of the hose assembly.

② Hose assembly maximum outside dimension is 1.33 in. (33.8 mm).

Sanitary Kwik-Clamp 45° Elbows

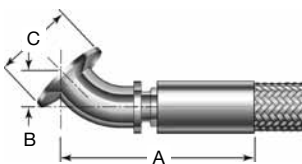

Kwik-Clamp Size in.	Nominal Hose Size Designator	End Connection Designator		Dimensions, in. (mm)				Pressure Rating psig (bar)
		Standard Surface	Electro-polished	A Max	B	Minimum Inside Diameter	C, Flange Outside Diameter ^①	
1/2	8	KA8	AE8	3.05 (77.5)	0.70 (17.8)	0.34 (8.6)	0.98 (25.0)	1500 (103)
3/4	12	KA12	AE12	3.85 (97.8)	0.69 (17.6)	0.54 (13.7)	0.98 (25.0) ^②	1500 (103)
1	16	KA16	AE16	4.02 (102)	0.81 (20.5)	0.78 (19.8)	1.98 (50.3)	500 (34.4)
1 1/2	24	KA24	AE24	5.60 (142)	1.03 (26.2)	1.24 (31.4)	1.98 (50.3)	500 (34.4)
2	32	KA32	AE32	7.03 (179)	1.27 (32.3)	1.68 (42.6)	2.52 (64.0)	450 (31.0)

① The C dimension is also the maximum outside dimension of the hose assembly.

② Hose assembly maximum outside dimension is 1.33 in. (33.8 mm).

Coreflex Series Hose—End Connections

Tube Butt Welds^①

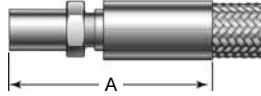

① 316L SS material with a 15 µin. (0.38 µm) R_a max surface finish prior to crimp.

Tube Butt Weld Size in.	Wall Thickness in.	Nominal Hose Size Designator	End Connection Designator	Dimensions, in. (mm)			Pressure Rating psig (bar)
				A Max	Minimum Inside Diameter	Maximum Outside Dimension	
1/2	0.049	8	TB8	2.70 (68.6)	0.34 (8.6)	1.04 (26.4)	Determined by hose
3/4	0.049	12	TB12	3.26 (82.8)	0.54 (13.7)	1.35 (34.3)	
1	0.065	16	TB16	3.26 (82.8)	0.78 (19.8)	1.75 (44.5)	
1 1/2	0.095	24	TB24	4.65 (118)	1.24 (31.4)	2.20 (55.9)	
2	0.109	32	TB32	5.56 (141)	1.68 (42.6)	2.75 (69.9)	

SAE 37° (JIC) Female Swivel

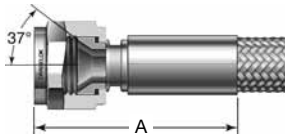

SAE 37° (JIC) Female Swivel Size in.	Nominal Hose Size Designator	End Connection Designator	Dimensions, in. (mm)			Pressure Rating psig (bar)
			A Max	Minimum Inside Diameter	Maximum Outside Dimension	
1/8	2	AS2	1.43 (36.3)	0.070 (1.7)	0.55 (14.0)	Determined by hose
1/4	4	AS4	1.57 (39.8)	0.16 (4.0)	0.66 (16.8)	
3/8	6	AS6	1.97 (50.0)	0.26 (6.6)	0.82 (20.8)	
1/2	8	AS8	2.28 (57.9)	0.34 (8.6)	1.04 (26.4)	
3/4	12	AS12	2.92 (74.2)	0.54 (13.7)	1.35 (34.3)	
1	16	AS16	2.93 (74.4)	0.78 (19.8)	1.75 (44.5)	
1 1/2	24	AS24	3.72 (94.5)	1.24 (31.4)	2.61 (66.3)	
2	32	AS32	4.61 (117)	1.68 (42.6)	3.33 (84.6)	

Female Cam and Groove

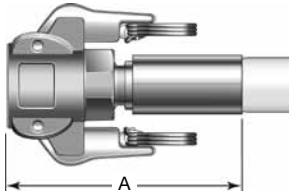

Female Cam and Groove Size in.	Nominal Hose Size Designator	End Connection Designator	Dimensions, in. (mm)			Pressure Rating psig (bar)
			A Max	Minimum Inside Diameter	Maximum Outside Dimension	
3/4	12	GF12	4.03 (102)	0.54 (13.7)	3.27 (83.1)	250 (17.2)
1	16	GF16	4.53 (115)	0.78 (19.8)	3.50 (88.9)	
1 1/2	24	GF24	5.39 (137)	1.24 (31.4)	4.44 (113)	
2	32	GF32	6.30 (160)	1.68 (42.6)	4.82 (122)	

The A dimension may vary if armor guard hose cover is ordered.

Male Cam and Groove

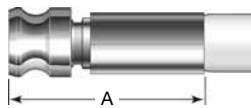

Male Cam and Groove Size in.	Nominal Hose Size Designator	End Connection Designator	Dimensions, in. (mm)			Pressure Rating psig (bar)
			A Max	Minimum Inside Diameter	Maximum Outside Dimension	
3/4	12	GM12	2.92 (74.2)	0.54 (13.7)	1.27 (32.3)	250 (17.2)
1	16	GM16	3.54 (89.9)	0.78 (19.8)	1.45 (36.8)	
1 1/2	24	GM24	4.40 (112)	1.24 (31.4)	2.11 (53.6)	
2	32	GM32	5.15 (131)	1.68 (42.6)	2.47 (62.7)	

See next page for more end connections.

Coreflex Series Hose—End Connections

Tube Stubs

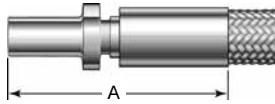

Tube Stub Size	Wall Thickness	Nominal Hose Size Designator	End Connection Designator	Dimensions			Pressure Rating psig (bar)
				A Max	Minimum Inside Diameter	Maximum Outside Dimension	
Dimensions, in. (mm)							
1/8	0.035	2	TN2	1.84 (46.7)	0.050 (1.2)	0.55 (14.0)	Determined by hose
1/4	0.035	4	TN4	1.94 (49.3)	0.17 (4.3)	0.59 (15.0)	
3/8	0.049	6	TN6	2.37 (60.2)	0.27 (6.8)	0.82 (20.8)	
1/2	0.065	8	TN8	2.88 (73.2)	0.34 (8.6)	1.04 (26.4)	
3/4	0.075	12	TN12	3.47 (88.1)	0.59 (14.9)	1.35 (34.3)	
1	0.095	16	TN16	3.65 (92.7)	0.80 (20.3)	1.75 (44.5)	
1 1/2	0.134	24	TN24	4.97 (126)	1.22 (30.9)	2.20 (55.9)	
2	0.188	32	TN32	6.32 (161)	1.62 (41.1)	2.74 (69.6)	
Dimensions, mm (in.)							
3	0.80	2	TE3	38.6 (1.52)	1.3 (0.051)	14.0 (0.55)	Determined by hose
6	0.80	4	TE6	40.1 (1.58)	4.3 (0.17)	15.0 (0.59)	
8	1.8	4	TE8	40.1 (1.58)	5.3 (0.21)	15.0 (0.59)	
8	0.90	6	TE8	56.9 (2.24)	6.1 (0.24)	20.8 (0.82)	
10	1.3	6	TE10	58.4 (2.30)	7.1 (0.28)	21.8 (0.86)	
12	2.0	6	TE12	64.3 (2.53)	7.9 (0.31)	21.8 (0.86)	
12	1.5	8	TE12	72.9 (2.87)	8.9 (0.35)	26.4 (1.04)	
18	2.0	12	TE18	85.6 (3.37)	13.7 (0.54)	34.3 (1.35)	
25	2.5	16	TE25	94.0 (3.70)	19.6 (0.77)	44.5 (1.75)	
38	3.5	24	TE38	118 (4.65)	30.7 (1.21)	55.9 (2.20)	
50	5.0	32	TE50	148 (5.83)	39.9 (1.57)	69.6 (2.74)	

Female VCO O-Ring Face Seal Fittings

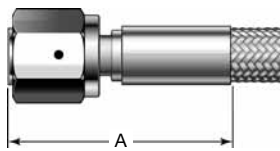

VCO Size in.	Nominal Hose Size Designator	End Connection Designator	Dimensions, in. (mm)			Pressure Rating psig (bar)
			A Max	Minimum Inside Diameter	Maximum Outside Dimension	
1/4	4	VF4	1.67 (42.4)	0.16 (4.0)	0.80 (20.3)	Determined by hose
1/2	8	VF8	2.18 (55.4)	0.34 (8.6)	1.16 (29.5)	
3/4	12	VF12	2.79 (70.9)	0.54 (13.7)	1.74 (44.2)	
1	16	VF16	2.67 (67.8)	0.78 (19.8)	2.03 (51.6)	

Female VCR Metal Gasket Face Seal Fittings

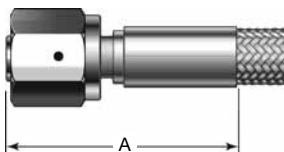

VCR Size in.	Nominal Hose Size Designator	End Connection Designator	Dimensions, in. (mm)			Pressure Rating psig (bar)
			A Max	Minimum Inside Diameter	Maximum Outside Dimension	
1/4	4	RF4	1.76 (44.7)	0.16 (4.0)	0.87 (22.1)	Determined by hose
1/2	8	RF8	2.37 (60.2)	0.34 (8.6)	1.23 (31.2)	
3/4	12	RF12	3.08 (78.2)	0.54 (13.7)	1.74 (44.2)	
1	16	RF16	3.20 (81.3)	0.78 (19.8)	2.03 (51.6)	

Coreflex Series Hose—End Connections

TS Series Sanitary Clamps^①

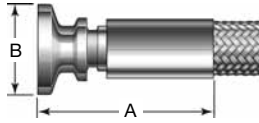

① 316L SS material with a 15 µin. (0.38 µm) R_a max surface finish prior to crimp.

Sanitary Clamp Size in.	Nominal Hose Size Designator	End Connection Designator	Dimensions, in. (mm)			Maximum Outside Dimension	Pressure Rating psig (bar)
			A Max	Minimum Inside Diameter	B, Flange Outside Diameter		
1/2	8	TS8	2.20 (55.9)	0.34 (8.6)	0.98 (25.0)	1.04 (26.4)	3100 (213)
3/4	12	TS12	2.70 (68.6)	0.54 (13.7)	0.98 (25.0)	1.35 (34.3)	2800 (192)
1	16	TS16	2.88 (73.2)	0.78 (19.8)	1.98 (50.3)	1.98 (50.3)	1200 (82.6)
1 1/2	24	TS24	3.35 (85.1)	1.24 (31.4)	1.98 (50.3)	2.20 (55.9)	1200 (82.6)
2	32	TS32	4.01 (102)	1.68 (42.6)	2.52 (64.0)	2.74 (69.6)	650 (44.7)

Male Pipe Threads, ISO/BSP Tapered (ISO 7)

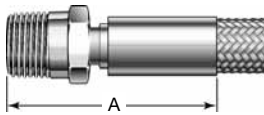

Male Pipe Thread, ISO/BSP Tapered Size in.	Nominal Hose Size Designator	End Connection Designator	Dimensions, in. (mm)			Pressure Rating psig (bar)
			A Max	Minimum Inside Diameter	Maximum Outside Dimension	
1/4	4	MT4	1.91 (48.5)	0.16 (4.0)	0.66 (16.8)	Determined by hose
3/8	6	MT6	2.31 (58.7)	0.26 (6.6)	0.82 (20.8)	
1/2	8	MT8	2.72 (69.1)	0.34 (8.6)	1.04 (26.4)	
3/4	12	MT12	3.26 (82.8)	0.54 (13.7)	1.35 (34.3)	
1	16	MT16	3.45 (87.6)	0.78 (19.8)	1.75 (44.5)	
1 1/2	24	MT24	4.25 (108)	1.24 (31.4)	2.31 (58.7)	
2	32	MT32	5.12 (130)	1.68 (42.6)	2.89 (73.4)	

Male ISO/BSP Parallel Threads with 60° Male Cone (ISO 228)

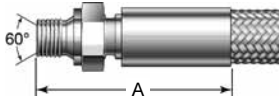

ISO/BSP Parallel, 60° Male Cone Size in.	Nominal Hose Size Designator	End Connection Designator	Dimensions, in. (mm)			Pressure Rating psig (bar)
			A Max	Minimum Inside Diameter	Maximum Outside Dimension	
1/4	4	MS4	1.99 (50.5)	0.16 (4.0)	0.87 (22.1)	Determined by hose
3/8	6	MS6	2.38 (60.5)	0.26 (6.6)	1.01 (25.7)	
1/2	8	MS8	2.65 (67.3)	0.34 (8.6)	1.23 (31.2)	
3/4	12	MS12	3.37 (85.6)	0.54 (13.7)	1.52 (38.6)	
1	16	MS16	3.38 (85.9)	0.78 (19.8)	1.88 (47.8)	
1 1/2	24	MS24	4.21 (107)	1.24 (31.4)	2.53 (64.3)	
2	32	MS32	5.16 (131)	1.68 (42.6)	3.18 (80.8)	

Female Pipe Threads, ISO/BSP Tapered (ISO 7)

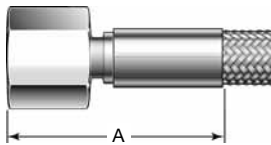

Female Pipe Thread, ISO/BSP Tapered Size in.	Nominal Hose Size Designator	End Connection Designator	Dimensions, in. (mm)			Pressure Rating psig (bar)
			A Max	Minimum Inside Diameter	Maximum Outside Dimension	
1/4	4	FT4	1.85 (47.0)	0.16 (4.0)	0.87 (22.1)	Determined by hose
3/8	6	FT6	2.32 (58.9)	0.26 (6.6)	1.01 (25.7)	
1/2	8	FT8	2.67 (67.8)	0.34 (8.6)	1.23 (31.2)	
3/4	12	FT12	3.37 (85.6)	0.54 (13.7)	1.52 (38.6)	
1	16	FT16	3.45 (87.6)	0.78 (19.8)	1.88 (47.8)	
1 1/2	24	FT24	4.15 (105)	1.24 (31.4)	2.75 (69.9)	
2	32	FT32	4.99 (127)	1.68 (42.6)	3.32 (84.3)	

See next page for more end connections.

Coreflex Series Hose—End Connections

Female ISO/BSP Parallel Threads (ISO 228)

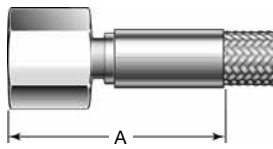

ISO/BSP Parallel Thread Size in.	Nominal Hose Size Designator	End Connection Designator	Dimensions, in. (mm)			Pressure Rating psig (bar)
			A Max	Minimum Inside Diameter	Maximum Outside Dimension	
1/4	4	FS4	2.06 (52.3)	0.16 (4.0)	0.87 (22.1)	Determined by hose
3/8	6	FS6	2.57 (65.3)	0.26 (6.6)	1.09 (27.7)	
1/2	8	FS8	2.84 (72.1)	0.34 (8.6)	1.23 (31.2)	
3/4	12	FS12	3.39 (86.1)	0.54 (13.7)	1.59 (40.4)	
1	16	FS16	3.46 (87.9)	0.78 (19.8)	1.88 (47.8)	
1 1/2	24	FS24	4.29 (109)	1.24 (31.4)	2.60 (66.0)	
2	32	FS32	4.95 (126)	1.68 (42.6)	3.18 (80.8)	

Female Swivel ISO/BSP Parallel Threads with 30° Cone

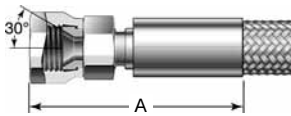

Swivel ISO/BSP Parallel Thread, 30° Cone Size in.	Nominal Hose Size Designator	End Connection Designator	Dimensions, in. (mm)			Pressure Rating psig (bar)
			A Max	Minimum Inside Diameter	Maximum Outside Dimension	
1/4	4	BS4	2.19 (55.6)	0.16 (4.0)	0.87 (22.1)	Determined by hose
3/8	6	BS6	2.72 (69.1)	0.26 (6.6)	1.01 (25.7)	
1/2	8	BS8	3.10 (78.7)	0.34 (8.6)	1.23 (31.2)	

Female Swivel ISO/BSP Parallel Threads with 60° Cone

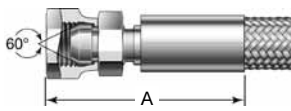

Swivel ISO/BSP Parallel Thread, 60° Cone Size in.	Nominal Hose Size Designator	End Connection Designator	Dimensions, in. (mm)			Pressure Rating psig (bar)
			A Max	Minimum Inside Diameter	Maximum Outside Dimension	
1/4	4	BM4	2.08 (52.8)	0.16 (4.0)	0.87 (22.1)	Determined by hose
3/8	6	BM6	2.59 (65.8)	0.26 (6.6)	1.01 (25.7)	
1/2	8	BM8	2.95 (74.9)	0.34 (8.6)	1.23 (31.2)	

JIS(A)/ISO 2852-Type Sanitary^①

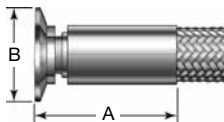

JIS(A)/ISO 2852-Type Sanitary Size	Nominal Hose Size Designator	End Connection Designator	Dimensions, in. (mm)			Pressure Rating psig (bar)
			A Max	Minimum Inside Diameter	B, Flange Outside Diameter ^②	
8A	6	JS8	2.16 (54.9)	0.26 (6.6)	1.34 (34.0)	500 (34.4)
10A	8	JS10	2.34 (59.4)	0.34 (8.6)		
15A	12	JS15	2.88 (73.2)	0.54 (13.7)		

^① 316L SS material with a 15 µin. (0.38 µm) R_a max surface finish prior to crimp.

^② The B dimension is also the maximum outside dimension of the hose assembly.

ISO-KF Vacuum Flange

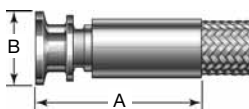

ISO-KF Vacuum Flange Size mm	Nominal Hose Size Designator	End Connection Designator	Dimensions, mm (in.)				Pressure Rating bar (psig)
			A Max	Minimum Inside Diameter	B, Flange Outside Diameter	Maximum Outside Dimension	
16	12	KF16	71.1 (2.80)	13.7 (0.54)	30.0 (1.18)	34.3 (1.35)	10.0 (145)
25	16	KF25	68.6 (2.70)	19.8 (0.78)	40.0 (1.57)	44.5 (1.75)	
40	24	KF40	82.6 (3.25)	31.4 (1.24)	55.0 (2.16)	55.9 (2.20)	
50	32	KF50	106 (4.16)	42.6 (1.68)	75.0 (2.95)	75.2 (2.96)	

Coreflex Series Hose—End Connections

Sanitary DIN 11864-3 Form A^①

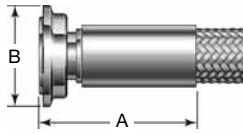

① 316L SS material with a 15 µin. (0.38 µm) R_a max surface finish prior to crimp.

Sanitary DIN 11864-3 Form A Size mm	Nominal Hose Size Designator	End Connection Designator	Dimensions, mm (in.)			Pressure Rating bar (psig)
			A Max	Minimum Inside Diameter	B, Flange Outside Diameter ^②	
10	6	DB10	51.8 (2.04)	6.6 (0.26)	35.6 (1.40)	40.0 (580)
15	8	DB15	56.9 (2.24)	8.6 (0.34)	34.0 (1.34)	
	12	DB15	70.4 (2.77)	13.7 (0.54)	34.0 (1.34)	
20	12	DB20	60.5 (2.38)	13.7 (0.54)	50.3 (1.98)	
25	16	DB25	67.3 (2.65)	19.8 (0.78)	50.3 (1.98)	
40	24	DB40	83.6 (3.29)	31.4 (1.24)	64.0 (2.52)	
50	32	DB50	101 (3.97)	42.6 (1.68)	77.5 (3.05)	

② The B dimension is also the maximum outside dimension of the hose assembly.

Female DIN 11851 with Nut^①

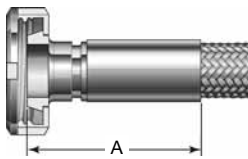

① 316L SS material with a 15 µin. (0.38 µm) R_a max surface finish prior to crimp.

Female DIN 11851 with Nut Size mm	Nominal Hose Size Designator	End Connection Designator	Dimensions, mm (in.)			Pressure Rating bar (psig)
			A Max	Minimum Inside Diameter	Maximum Outside Dimension	
15	8	DF15	57.4 (2.26)	8.6 (0.34)	44.2 (1.74)	40.0 (580)
20	12	DF20	73.7 (2.90)	13.7 (0.54)	54.4 (2.14)	
25	16	DF25	70.6 (2.78)	19.8 (0.78)	63.2 (2.49)	
40	24	DF40	87.6 (3.45)	31.4 (1.24)	78.2 (3.08)	
50	32	DF50	106 (4.19)	42.6 (1.68)	92.2 (3.63)	24.8 (360)

ASME Class 150 Lap Joint Flange

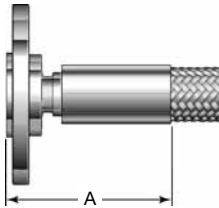

ASME Class 150 Lap Joint Flange Size in.	Nominal Hose Size Designator	End Connection Designator	Dimensions, in. (mm)			Pressure Rating psig (bar)
			A Max	Minimum Inside Diameter	Maximum Outside Dimension	
1/2	8	GA8	2.75 (69.9)	0.34 (8.6)	3.56 (90.4)	275 (18.9)
3/4	12	GA12	3.41 (86.6)	0.54 (13.7)	3.91 (99.3)	
1	16	GA16	3.38 (85.9)	0.78 (19.8)	4.28 (109)	
1 1/2	24	GA24	4.09 (104)	1.24 (31.4)	5.03 (128)	
2	32	GA32	5.06 (129)	1.68 (42.6)	6.03 (153)	

JIS 10K Lap Joint Flange

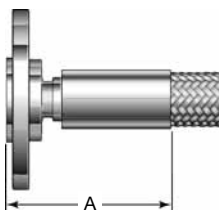

JIS 10K Lap Joint Flange Size mm	Nominal Hose Size Designator	End Connection Designator	Dimensions, mm (in.)			Pressure Rating bar (psig)
			A Max	Minimum Inside Diameter	Maximum Outside Dimension	
15	8	HA15	69.9 (2.75)	8.6 (0.34)	95.3 (3.75)	9.7 (142)
20	12	HA20	86.6 (3.41)	13.7 (0.54)	100 (3.95)	
25	16	HA25	85.9 (3.38)	19.8 (0.78)	125 (4.93)	
40	24	HA40	104 (4.09)	31.4 (1.24)	140 (5.52)	
50	32	HA50	123 (4.86)	42.6 (1.68)	155 (6.11)	

DIN PN10 Lap Joint Flange

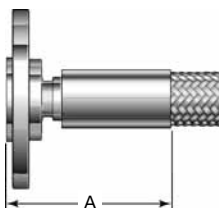

DIN PN10 Lap Joint Flange Size mm	Nominal Hose Size Designator	End Connection Designator	Dimensions, mm (in.)			Pressure Rating bar (psig)
			A Max	Minimum Inside Diameter	Maximum Outside Dimension	
15	8	FA15	69.9 (2.75)	8.6 (0.34)	95.3 (3.75)	10.0 (145)
20	12	FA20	86.6 (3.41)	13.7 (0.54)	105 (4.14)	
25	16	FA25	88.9 (3.50)	19.8 (0.78)	115 (4.54)	
40	24	FA40	121 (4.76)	31.4 (1.24)	150 (5.92)	
50	32	FA50	123 (4.86)	42.6 (1.68)	165 (6.51)	

See next page for more end connections.

Coreflex Series Hose—End Connections

Sanitary I-Line Male^①

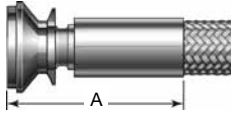

① 316L SS material with a 15 µin. (0.38 µm) R_a max surface finish prior to crimp.

Sanitary I-Line Male Size in.	Nominal Hose Size Designator	End Connection Designator	Dimensions, in. (mm)			Pressure Rating psig (bar)
			A Max	Minimum Inside Diameter	Maximum Outside Dimension	
1	16	MD16	2.99 (75.9)	0.78 (19.8)	2.01 (51.1)	1220 (84.0)
1 1/2	24	MD24	3.70 (94.0)	1.24 (31.4)	2.20 (55.9)	1220 (84.0)
2	32	MD32	4.45 (113)	1.68 (42.6)	2.74 (69.6)	900 (62.0)

Sanitary I-Line Female^①

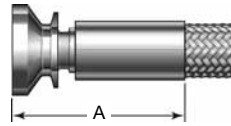

① 316L SS material with a 15 µin. (0.38 µm) R_a max surface finish prior to crimp.

Sanitary I-Line Female Size in.	Nominal Hose Size Designator	End Connection Designator	Dimensions, in. (mm)			Pressure Rating psig (bar)
			A Max	Minimum Inside Diameter	Maximum Outside Dimension	
1	16	FD16	2.98 (75.7)	0.78 (19.8)	2.01 (51.1)	1220 (84.0)
1 1/2	24	FD24	3.69 (93.7)	1.24 (31.4)	2.20 (55.9)	1220 (84.0)
2	32	FD32	4.44 (113)	1.68 (42.6)	2.74 (69.6)	900 (62.0)

Sanitary (DIN 32676)^①

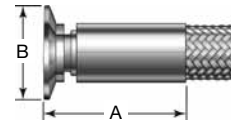

① 316L SS material with a 15 µin. (0.38 µm) R_a max surface finish prior to crimp.

Sanitary (DIN 32676) Size mm	Nominal Hose Size Designator	End Connection Designator	Dimensions, mm (in.)			Pressure Rating bar (psig)
			A Max	Minimum Inside Diameter	B, Flange Outside Diameter ^②	
10	4	DA10	46.0 (1.81)	4.0 (0.16)	34.0 (1.34)	15.8 (230)
	6	DA10	56.1 (2.21)	6.6 (0.26)	34.0 (1.34)	
	8	DA10	56.6 (2.23)	8.6 (0.34)	34.0 (1.34)	
15	8	DA15	58.9 (2.32)	11.1 (0.44)	34.0 (1.34)	
	12	DA15	72.6 (2.86)	13.7 (0.54)	34.0 (1.34)	
20	12	DA20	72.6 (2.86)	13.7 (0.54)	34.0 (1.34)	
25	16	DA25	72.6 (2.86)	19.8 (0.78)	50.5 (1.99)	
32	16	DA32	72.6 (2.86)	19.8 (0.78)	50.5 (1.99)	
40	24	DA40	84.6 (3.33)	31.4 (1.24)	50.5 (1.99)	
50	32	DA50	113 (4.44)	42.6 (1.68)	64.0 (2.52) ^③	

② The B dimension is also the maximum outside dimension of the hose assembly.

③ Hose assembly maximum outside dimension is 69.6 mm (2.74 in.).

Sanitary (ISO 2852)^①

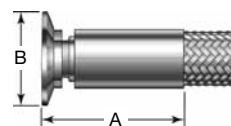

① 316L SS material with a 15 µin. (0.38 µm) R_a max surface finish prior to crimp.

Sanitary (ISO 2852) Size mm	Nominal Hose Size Designator	End Connection Designator	Dimensions, mm (in.)			Pressure Rating bar (psig)
			A Max	Minimum Inside Diameter	B, Flange Outside Diameter ^②	
12	8	ES12	58.4 (2.30)	8.6 (0.34)	34.0 (1.34)	103 (1500)
13	6	ES13	54.1 (2.13)	6.6 (0.26)	34.0 (1.34)	
20	12	ES20	72.6 (2.86)	13.7 (0.54)	34.0 (1.34)	
26	12	ES26	73.9 (2.91)	13.7 (0.54)	50.5 (1.99)	
25	16	ES25	72.4 (2.85)	19.8 (0.78)	50.5 (1.99)	34.4 (500)
40	24	ES40	88.9 (3.50)	31.4 (1.24)	64.0 (2.52) ^③	34.4 (500)
50	32	ES50	106 (4.16)	42.6 (1.68)	64.0 (2.52) ^④	31.0 (450)

② The B dimension is also the maximum outside dimension of the hose assembly.

③ Hose assembly maximum outside dimension is 64.3 mm (2.53 in.).

④ Hose assembly maximum outside dimension is 69.6 mm (2.74 in.).

PFA Series PFA Tubing

Features

- Chemically resistant, translucent PFA flexible tubing.
- Smooth-bore, perfluoroalkoxy (PFA) material.
- Size range of 1/8 through 1 in. and 6 through 12 mm and working pressures up to 275 psig (18.9 bar).
- PFA tubing material in accordance with ASTM D3307, Type II.
- Flexible tubing commonly used where chemical compatibility is desired.
- Designed for use with both Swagelok PFA tube fittings and metal Swagelok tube fittings.
- Groove cutter required for installation of Swagelok PFA tube fittings. See page 62.
- Tube cutter tool is available. See page 85 for details.



Technical Data

Pressure ratings are for properly grooved Swagelok PFA tubing used with Swagelok PFA tube fittings and for Swagelok PFA tubing used with metal Swagelok tube fittings.

Fractional Tubing

Tubing Wall, in.	0.030	0.047	0.062				
Nominal Tube Size in.	1/8	1/4	1/4	3/8	1/2	3/4	1
Temperature °F (°C)	Working Pressure psig (bar)						
70 (20)	275 (18.9)	200 (13.7)	275 (18.9)	180 (12.4)	125 (8.6)	83 (5.7)	61 (4.2)
100 (37)	245 (16.8)	180 (12.4)	245 (16.8)	155 (10.6)	115 (7.9)	73 (5.0)	54 (3.7)
200 (93)	145 (9.9)	110 (7.5)	145 (9.9)	93 (6.4)	68 (4.6)	43 (2.9)	32 (2.2)
300 (148)	87 (5.9)	64 (4.4)	87 (5.9)	48 (3.3)	32 (2.2)	19 (1.3)	13 (0.89)
400 (204)	47 (3.2)	34 (2.3)	47 (3.2)	11 (0.75)	11 (0.75)	5.0 (0.34)	3.0 (0.20)

Metric Tubing

Tubing Wall, mm	1				1.5			
Nominal Tube Size mm	6	8	10	12	6	8	10	12
Temperature °C (°F)	Working Pressure bar (psig)							
20 (70)	12 (174)	8.9 (129)	7.0 (101)	5.7 (82)	19 (275)	14 (203)	11 (159)	8.9 (129)
50 (122)	9.7 (140)	7.1 (103)	5.5 (79)	4.6 (66)	15 (217)	11 (159)	8.7 (126)	7.1 (103)
100 (212)	6.1 (88)	4.4 (63)	3.4 (49)	2.8 (40)	9.5 (137)	6.9 (100)	5.3 (76)	4.4 (63)
150 (302)	3.8 (55)	2.5 (36)	1.8 (26)	1.4 (20)	5.9 (85)	4.0 (58)	2.9 (42)	2.2 (31)
200 (392)	2.2 (31)	1.3 (18)	0.8 (11)	0.6 (8.7)	3.4 (49)	2.0 (29)	1.3 (18)	0.9 (13)

Cleaning and Packaging

Swagelok PFA tubing is cleaned in accordance with Swagelok *Standard Cleaning and Packaging (SC-10)*, MS-06-62. Each tube length is bagged individually and boxed.

See next page for ordering information.

PFA Series PFA Tubing

Ordering Information

Select an ordering number.



Nominal Tube Size	Length	Ordering Number	Nominal Wall Thickness
Dimensions	ft (m)		in.
1/8 in.	100 (30.5)	PFA-T2-030-100	0.030
	500 (152)	PFA-T2-030-500	
1/4 in.	100 (30.5)	PFA-T4-047-100	0.047
		PFA-T4-062-100	0.062
3/8 in.	50 (15.2)	PFA-T6-062-50	0.062
	100 (30.5)	PFA-T6-062-100	
1/2 in.	50 (15.2)	PFA-T8-062-50	0.062
	100 (30.5)	PFA-T8-062-100	
3/4 in.	50 (15.2)	PFA-T12-062-50	0.062
1 in.	50 (15.2)	PFA-T16-062-50	0.062
Dimensions	m (ft)		mm
6 mm	30 (98.4)	PFA-T6M-1M-30M	1.0
		PFA-T6M-1.5M-30M	1.5
8 mm		PFA-T8M-1M-30M	1.0
		PFA-T8M-1.5M-30M	1.5
10 mm		PFA-T10M-1M-30M	1.0
		PFA-T10M-1.5M-30M	1.5
12 mm		PFA-T12M-1M-30M	1.0
		PFA-T12M-1.5M-30M	1.5

Custom sizes, wall thickness, and lengths are available. Contact your authorized Swagelok representative.

Groove Cutter

⚠ PFA tubing MUST be grooved for use with PFA tube fittings. Use the Swagelok groove cutter tool. It is not necessary to groove tubing for use with metal fittings.

Groove PFA tubing for use with Swagelok PFA tube fittings.



For 1/4, 3/8,
and 1/2 in. tubing



For 1/8 in.
tubing

Tube Size in.	Ordering Number
1/8	MS-GC-2
1/4	MS-GC-4
3/8	MS-GC-6
1/2	MS-GC-8

PFA Tube Fittings



Swagelok PFA tube fittings in sizes from 1/8 to 1/2 in. are available for use with PFA tubing. For more information on Swagelok PFA tube fittings, see the Swagelok *PFA Tube Fittings* catalog, MS-01-05.

Ultrahigh-Purity PFA Tubing (PFA4 and PFA9D)



Swagelok PFA tubing is available in ultrahigh-purity (PFA4) and advanced (fluorosurfactant resistant) ultrahigh-purity (PFA9D) grades. For more information, see the Swagelok *Ultrahigh-Purity PFA Tubing—PFA4 and PFA9D* catalog, MS-02-196.

High-Purity PFA Fine Thread Flare Tube Fittings



Swagelok high-purity PFA fine thread flare fittings in sizes from 1/4 to 1 in. are available for use with PFA tubing. For more information on Swagelok high-purity PFA fine thread flare fittings, see the Swagelok *High-Purity PFA Fine Thread Flare Tube Fittings* catalog, MS-02-195.

LT Series Vinyl Tubing

Features

- General purpose, clear vinyl, flexible tubing.
- Smooth-bore, polyvinyl chloride (PVC) material.
- Size range of 1/8 through 1/2 in. and working pressures from vacuum up to 40 psig (2.7 bar).
- Can be used with Swagelok tube fitting and metal insert.
- Good for a variety of applications where system transparency is desired.
- Bulk tubing and end connections available for field assembly.
- Thick-wall tubing available in 1/4 and 3/8 in. sizes for vacuum-service applications.

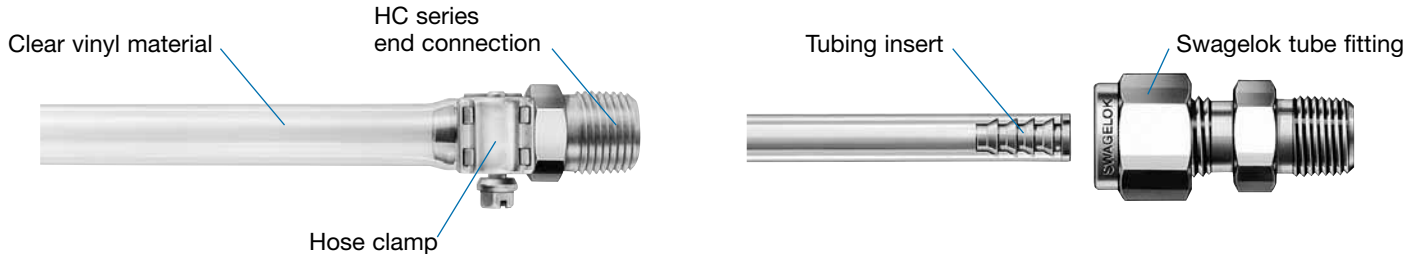

Technical Data and Ordering Information

- Pressure ratings are based on tubing used with an HC series end connection secured by a clamp or with a Swagelok tube fitting and metal insert.
- Tubing is sold in 50 ft (15.2 m) rolls.
- Select an ordering number.

Nominal Inside Diameter in.	Nominal Outside Diameter in.	Temperature Range °F (°C)	Working Pressure at 70°F (20°C) psig (bar)	Bulk Tubing Weight lb/ft (kg/m)	Ordering Number
Standard Wall					
1/8	1/4	-40 to 165 (-40 to 73)	40 (2.7)	0.02 (0.03)	LT-2-4
3/16	5/16		30 (2.0)	0.03 (0.04)	LT-3-5
1/4	3/8		25 (1.7)	0.04 (0.05)	LT-4-6
3/8	1/2		15 (1.0)	0.05 (0.07)	LT-6-8
1/2	5/8		10 (0.68)	0.06 (0.08)	LT-8-10
Thick-Wall Vacuum					
1/4	5/8	-40 to 165 (-40 to 73)	Vacuum service over entire temperature range	0.13 (0.20)	LT-4-10V
3/8	7/8			0.27 (0.41)	LT-6-14V



VINYL

Pressure-Temperature Ratings

Nominal Tubing Size in.	Standard Wall				
	1/8	3/16	1/4	3/8	1/2
Temperature °F (°C)	Working Pressure, psig (bar)				
-40 (-40) to 70 (20)	40 (2.7)	30 (2.0)	25 (1.7)	15 (1.0)	10 (0.68)
80 (26)	38 (2.6)	29 (1.9)	24 (1.6)	14 (1.0)	10 (0.68)
100 (37)	32 (2.2)	24 (1.6)	20 (1.3)	12 (0.82)	8.0 (0.55)
120 (48)	24 (1.6)	18 (1.2)	15 (1.0)	9.0 (0.62)	6.0 (0.41)
140 (60)	16 (1.1)	12 (0.82)	10 (0.68)	6.0 (0.41)	4.0 (0.27)
160 (71)	8.4 (0.57)	6.3 (0.43)	5.3 (0.36)	3.2 (0.21)	2.1 (0.14)
165 (73)	6.4 (0.44)	4.8 (0.33)	4.0 (0.27)	2.4 (0.16)	1.6 (0.11)

Cleaning and Packaging

Swagelok vinyl tubing is cleaned in accordance with Swagelok *Standard Cleaning and Packaging (SC-10)*, MS-06-62. Each roll of tubing is coiled individually and boxed.

See next page for connectors, sleeves, hose clamps, and tubing inserts.

HC Series—End Connections for Soft Tubing and Hose

Features

- HC series end connections allow for easy installation of soft plastic or rubber tubing.
- 316 stainless steel or brass material.
- Size range of 1/8 to 1 in.
- Reusable for other assemblies.
- May be used without a hose clamp or sleeve in low-pressure applications.
- Use of a hose clamp or sleeve may be required in higher-pressure applications.

Ordering Information

Add **SS** for 316 stainless steel or **B** for brass to the basic ordering number.

Example: **SS-2-HC-1-2**

For end connection barb dimensions, see page 66. To determine the cut length of bulk hose for field assembly, subtract dimension *B* for each end connection from the desired overall length.

Male Pipe Threads, NPT and ISO/BSP Tapered (ISO 7)

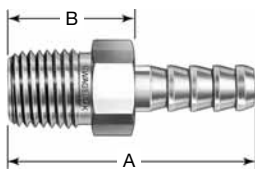

NPT and ISO/BSP Tapered Size in.	Nominal Tubing ID in.	Basic Ordering Number	Dimensions, in. (mm)			
			A	B	Minimum Inside Diameter	Maximum Outside Dimension
NPT						
1/8	1/8	-2-HC-1-2	1.08 (27.4)	0.68 (17.3)	0.13 (3.3)	0.51 (12.9)
	3/16	-3-HC-1-2	1.27 (32.2)		0.13 (3.3)	
	1/4	-4-HC-1-2	1.47 (37.3)		0.19 (4.8)	
	5/16	-5-HC-1-2	1.55 (39.4)		0.19 (4.8)	
1/4	1/8	-2-HC-1-4	1.26 (32.0)	0.86 (21.8)	0.08 (2.0)	0.65 (16.6)
	3/16	-3-HC-1-4	1.45 (36.8)		0.13 (3.3)	
	1/4	-4-HC-1-4	1.65 (41.9)		0.19 (4.8)	
	5/16	-5-HC-1-4	1.73 (43.9)		0.19 (4.8)	
	3/8	-6-HC-1-4	1.73 (43.9)		0.30 (7.6)	
	1/2	-8-HC-1-4	1.80 (45.7)		0.28 (7.1)	
3/8	1/4	-4-HC-1-6	1.66 (42.2)	0.87 (22.1)	0.19 (4.8)	0.80 (20.3)
	5/16	-5-HC-1-6	1.74 (44.2)	0.87 (22.1)	0.19 (4.8)	
	3/8	-6-HC-1-6	1.74 (44.2)	0.87 (22.1)	0.30 (7.6)	
	1/2	-8-HC-1-6	1.81 (46.0)	0.87 (22.1)	0.38 (9.7)	
	5/8	-10-HC-1-6	1.88 (47.8)	0.90 (22.9)	0.38 (9.7)	1.23 (31.3)
1/2	1/4	-4-HC-1-8	1.85 (47.0)	1.06 (26.9)	0.19 (4.8)	1.02 (25.8)
	5/16	-5-HC-1-8	1.96 (49.8)	1.09 (27.7)	0.19 (4.8)	
	3/8	-6-HC-1-8	1.96 (49.8)	1.09 (27.7)	0.30 (7.6)	
	1/2	-8-HC-1-8	2.03 (51.6)	1.09 (27.7)	0.38 (9.7)	
	5/8	-10-HC-1-8	2.07 (52.6)	1.09 (27.7)	0.47 (11.9)	1.23 (31.3)
	3/4	-12-HC-1-8	2.14 (54.4)	1.09 (27.7)	0.47 (11.9)	
3/4	5/8	-10-HC-1-12	2.07 (52.6)	1.09 (27.7)	0.50 (12.7)	1.23 (31.3)
	3/4	-12-HC-1-12	2.14 (54.4)	1.09 (27.7)	0.63 (16.0)	
	1	-16-HC-1-12	2.38 (60.5)	1.19 (30.2)	0.63 (16.0)	
1	3/4	-12-HC-1-16	2.43 (61.7)	1.38 (35.1)	0.63 (16.0)	1.60 (40.5)
	1	-16-HC-1-16	2.57 (65.3)		0.88 (22.4)	
ISO/BSP Tapered						
1/8	1/8	-2-HC-1-2RT	1.28 (32.5)	0.88 (22.4)	0.08 (2.0)	0.51 (12.9)
	1/4	-4-HC-1-2RT	1.47 (37.3)	0.68 (17.3)	0.19 (4.8)	
1/4	1/4	-4-HC-1-4RT	1.65 (41.9)	0.86 (21.8)	0.19 (4.8)	0.65 (16.6)
	3/8	-6-HC-1-4RT	1.73 (43.9)		0.30 (7.6)	
3/8	1/4	-4-HC-1-6RT	1.66 (42.2)	0.87 (22.1)	0.30 (7.6)	0.80 (20.3)
	3/8	-6-HC-1-6RT	1.74 (44.2)		0.30 (7.6)	
1/2	3/8	-6-HC-1-8RT	1.96 (49.8)	1.09 (27.7)	0.30 (7.6)	1.02 (25.8)
	1/2	-8-HC-1-8RT	2.03 (51.6)		0.38 (9.7)	

HC Series—End Connections for Soft Tubing and Hose

Female Pipe Threads, NPT

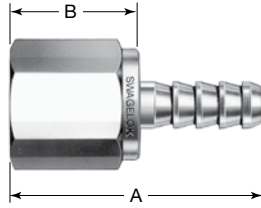

NPT Size in.	Nominal Tubing ID in.	Basic Ordering Number	Dimensions, in. (mm)			
			A	B	Minimum Inside Diameter	Maximum Outside Dimension
1/8	1/8	-2-HC-7-2	1.11 (28.2)	0.71 (18.0)	0.08 (2.0)	0.65 (16.6)
	3/16	-3-HC-7-2	1.29 (32.8)	0.70 (17.8)	0.13 (3.3)	
	1/4	-4-HC-7-2	1.47 (37.3)	0.68 (17.3)	0.19 (4.8)	
1/4	1/8	-2-HC-7-4	1.26 (32.0)	0.86 (21.8)	0.08 (2.0)	0.87 (22.1)
	3/16	-3-HC-7-4	1.44 (36.6)	0.85 (21.6)	0.13 (3.3)	
	1/4	-4-HC-7-4	1.64 (41.7)	0.85 (21.6)	0.19 (4.8)	
	5/16	-5-HC-7-4	1.73 (43.9)	0.86 (21.8)	0.19 (4.8)	
	3/8	-6-HC-7-4	1.69 (42.9)	0.82 (20.8)	0.30 (7.6)	
3/8	1/4	-4-HC-7-6	1.71 (43.4)	0.92 (23.4)	0.19 (4.8)	1.02 (25.8)
	5/16	-5-HC-7-6	1.82 (46.2)	0.95 (24.1)	0.19 (4.8)	
	3/8	-6-HC-7-6	1.78 (45.2)	0.91 (23.1)	0.30 (7.6)	
1/2	3/8	-6-HC-7-8	2.03 (51.6)	1.16 (29.5)	0.30 (7.6)	1.23 (31.3)
	1/2	-8-HC-7-8	2.13 (54.1)	1.19 (30.2)	0.38 (9.7)	

Swagelok Tube Adapters

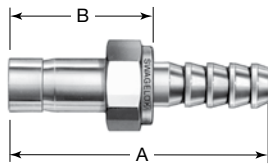

Tube Adapter Size	Nominal Tubing ID	Basic Ordering Number	Dimensions			
			A	B	Minimum Inside Diameter	Maximum Outside Dimension
Dimensions, in. (mm)						
1/8	1/8	-2-HC-A-201	1.36 (34.5)	0.96 (24.4)	0.08 (2.0)	0.36 (9.2)
1/4	1/8	-2-HC-A-401	1.45 (36.8)	1.05 (26.7)	0.08 (2.0)	0.44 (11.0)
	1/4	-4-HC-A-401	1.85 (47.0)	1.06 (26.9)	0.16 (4.1)	0.51 (12.9)
	5/16	-5-HC-A-401	1.93 (49.0)			0.51 (12.9)
	3/8	-6-HC-A-401	1.93 (49.0)			0.65 (16.6)
3/8	1/4	-4-HC-A-601	1.91 (48.5)	1.12 (28.4)	0.19 (4.8)	0.51 (12.9)
	3/8	-6-HC-A-601	1.99 (50.5)		0.27 (6.9)	0.65 (16.6)
	1/2	-8-HC-A-601	2.06 (52.3)			0.80 (20.3)
1/2	3/8	-6-HC-A-811	2.25 (57.2)	1.38 (35.1)	0.30 (7.6)	0.73 (18.4)
	1/2	-8-HC-A-811	2.32 (58.9)		0.38 (9.7)	0.80 (20.3)
3/4	3/4	-12-HC-A-1211	2.49 (63.3)	1.44 (36.6)	0.58 (14.7)	1.23 (31.3)
1	1	-16-HC-A-1611	3.05 (77.5)	1.86 (47.2)	0.80 (20.3)	1.60 (40.5)
Dimensions, mm (in.)						
6	1/4 in.	-4-HC-A-6MTA	47.8 (1.88)	27.7 (1.09)	4.1 (0.16)	12.9 (0.51)

Swagelok tube adapters are to be used only with Swagelok tube fittings.

Swagelok Tube Fittings

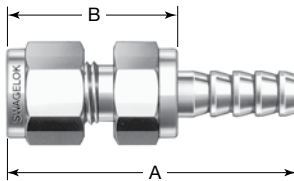

Tube Fitting Size in.	Nominal Tubing ID in.	Basic Ordering Number	Dimensions, in. (mm)			
			A	B	Minimum Inside Diameter	Maximum Outside Dimension
1/8	1/8	-2-HC-1-200	1.42 (36.1)	1.02 (25.9)	0.08 (2.0)	0.51 (12.9)
	1/4	-4-HC-1-200	1.81 (46.0)		0.09 (2.3)	
1/4	1/4	-4-HC-1-400	1.92 (48.8)	1.13 (28.7)	0.19 (4.8)	0.65 (16.6)
	3/8	-6-HC-1-400	1.99 (50.6)	1.12 (28.5)		
3/8	3/8	-6-HC-1-600	2.06 (52.3)	1.19 (30.2)	0.28 (7.1)	0.87 (22.1)
1/2	1/2	-8-HC-1-810	2.24 (56.9)	1.30 (33.0)	0.38 (9.7)	1.02 (25.8)

See next page for more hose connectors.

HC Series—End Connections for Soft Tubing and Hose

Sanitary Kwik-Clamps

- Smooth internal finish (20 μ in. R_a) and tapered orifice reduce entrapment and facilitate cleaning.

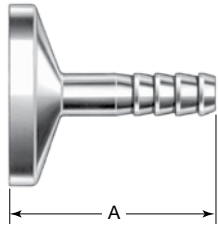

Kwik-Clamp Size in.	Nominal Tubing ID in.	Ordering Number	Dimensions, in. (mm)		
			A	Minimum Inside Diameter	Maximum Outside Dimension
1/2	3/16	SS-3-HC-8SC	1.10 (27.9)	0.13 (3.3)	0.99 (25.2)
	1/4	SS-4-HC-8SC	1.28 (32.5)	0.19 (4.8)	
	3/8	SS-6-HC-8SC	1.36 (34.5)	0.30 (7.6)	
	1/2	SS-8-HC-8SC ^①	1.44 (36.6)	0.38 (9.7)	
1	3/16	SS-3-HC-16SC	1.50 (38.1)	0.13 (3.3)	1.98 (50.3)
	1/4	SS-4-HC-16SC		0.19 (4.8)	
	3/8	SS-6-HC-16SC		0.30 (7.6)	
	1/2	SS-8-HC-16SC		0.38 (9.7)	

① Without 30° inside diameter taper.

End Connection Barb Dimensions

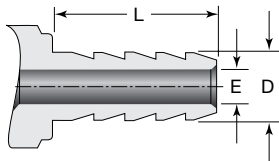

Nominal Tubing ID, in.	Dimensions, in. (mm)		
	D	E	L
1/8	0.15 (3.8)	0.08 (2.0)	0.40 (10.2)
3/16	0.23 (5.8)	0.12 (3.0)	0.59 (15.0)
1/4	0.30 (7.6)	0.19 (4.8)	0.79 (20.1)
5/16	0.38 (9.7)	0.19 (4.8)	0.87 (22.1)
3/8	0.45 (11.4)	0.30 (7.6)	0.87 (22.1)
1/2	0.60 (15.2)	0.38 (9.7)	0.94 (23.9)
5/8	0.75 (19.0)	0.50 (12.7)	0.98 (24.9)
3/4	0.90 (22.9)	0.63 (16.0)	1.05 (26.7)
1	1.20 (30.5)	0.88 (22.4)	1.19 (30.2)

Sleeves, Clamps, and Inserts

Hose Connector Sleeves



- Used to secure soft plastic or rubber tubing to hose connectors.
- Constructed of aluminum.
- Helically grooved ID and outer hex allow for easy installation with a wrench.
- Reusable for other assemblies.

Hose OD in.	Hose ID in.	Ordering Number	Dimensions, in.		
			A	E	Maximum Outside Dimension
1/4	1/8	A-2-L-4	0.40 (10.2)	0.26 (6.6)	0.44 (11.0)
3/8	1/4	A-4-L-6	0.79 (20.1)	0.41 (10.4)	0.65 (16.6)
7/16	1/4	A-4-L-7		0.46 (11.7)	0.73 (18.4)
1/2	1/4	A-4-L-8		0.52 (13.2)	0.80 (20.3)
7/16	5/16	A-5-L-7	0.87 (22.1)	0.48 (12.2)	0.73 (18.4)
1/2	3/8	A-6-L-8		0.55 (14.0)	0.80 (20.3)
9/16	3/8	A-6-L-9		0.61 (15.5)	0.87 (22.1)
5/8	7/16	A-7-L-10	0.94 (23.9)	0.69 (17.5)	0.94 (23.9)
11/16	1/2	A-8-L-11		0.76 (19.3)	1.02 (25.8)
1	3/4	A-12-L-16	1.07 (27.2)	1.10 (27.9)	1.45 (36.8)

Hose Clamps

- Material:
Band, saddle, housing: 304 SS
Screw: 304 SS / 305 SS
- 4-corner clinched saddle and housing with no spot welds to corrode or break.
- Smooth inside diameter surface provides high sealing pressure and reduces torque on screw.



Min Hose OD in.	Max Hose OD in.	Ordering Number	Band Marking
7/16	25/32	MS-HCC-6	6
1/2	29/32	MS-HCC-8	8
9/16	1 1/16	MS-HCC-10	10
11/16	1 1/4	MS-HCC-12	12
13/16	1 1/2	MS-HCC-16	16

Tubing Inserts

- Tubing inserts help secure soft plastic tubing used with standard Swagelok tube fittings.
- Some tubing inserts may be non-barbed depending on size and material.
- For materials, ordering information, and dimensions, see the Swagelok *Gaugeable Tube Fittings and Adapter Fittings* catalog, MS-01-140.



NG Series Nylon Hose

Features

- Electrically conductive nylon hose for CNG.
- Static dissipative, smooth-bore nylon core (Ω).
- Size range of 1/4 and 3/8 in. and working pressures up to 5000 psig (344 bar).
- Internal fiber reinforcement enhances hose pressure rating.
- Cover includes a blue stripe which provides an easily visible indicator of the static dissipative core.
- Perforated polyurethane cover resists abrasion.
- Designed for use with natural gas where static dissipation is required.
- Single, twin bonded, and vent bonded hoses are available in custom assemblies.

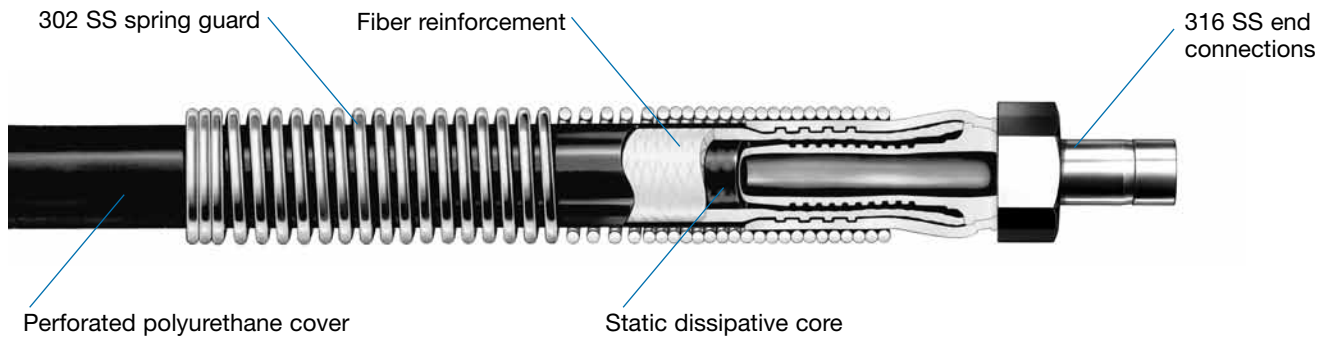
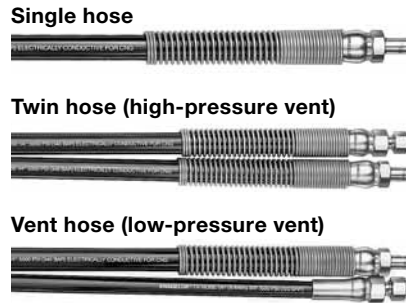

Technical Data

Hose Style (Series)	Nominal Hose Size in. (mm)	Inside Diameter in. (mm)	Outside Diameter in. (mm)	Minimum Inside Bend Radius in. (cm)	Temperature Range °F (°C)	Working Pressure at 70°F (20°C) psig (bar)	Burst Pressure at 70°F (20°C) psig (bar)	Bulk Hose Weight lb/ft (kg/m)
Single (NGS)	1/4 (6.4)	0.26 (6.6)	0.63 (16.0)	2.00 (5.08)	-40 to 150 (-40 to 65)	5000 (344)	20 000 (1378)	0.12 (0.17)
	3/8 (9.6)	0.38 (9.6)	0.77 (19.6)	4.00 (10.2)		0.15 (0.22)		
Twin (NGT)	1/4 (6.4)	0.26 (6.6)	0.63 (16.0)	2.00 (5.08)		Fill and vent 5000 (344)	Fill and vent 20 000 (1378)	0.25 (0.37)
	3/8 (9.6)	0.38 (9.6)	0.77 (19.6)	4.00 (10.2)		0.30 (0.44)		
Vent ^① (NGV)	1/4 (6.4)	Fill 0.26 (6.6) Vent 0.26 (6.6)	Fill 0.63 (16.0) Vent 0.63 (16.0)	2.00 (5.08)		Fill 5000 (344) Vent 1500 (103)	Fill 20 000 (1378) Vent 6 000 (413)	0.15 (0.22)
	3/8 (9.6)	Fill 0.38 (9.6) Vent 0.26 (6.6)	Fill 0.38 (9.6) Vent 0.63 (16.0)	4.00 (10.2)		0.25 (0.37)		

① Low-pressure vent line does not have static dissipative core.

Testing

Every Swagelok NG series hose assembly is factory tested for electrical conductivity.

Cleaning and Packaging

Swagelok conductive core hose components are cleaned in accordance with Swagelok *Standard Cleaning and Packaging (SC-10)*, MS-06-62. Each hose is bagged individually and boxed; longer hoses are coiled, bagged, and boxed.

Warning:
All equipment must be properly grounded to allow static dissipation and help to prevent static sparking.
Periodic inspection of hose assembly is recommended. End-to-end electrical resistance of the hose assembly must not exceed 5 M Ω .

See next page for ordering information.

NG Series Nylon Hose

Ordering Information and Dimensions

Custom Hose Assemblies—Single Hose

Build a hose assembly ordering number by combining the designators in the sequence shown below.



Typical Ordering Number

1 2 3 4 4 5 6
 SS - NGS 4 - T6 S4 - 40 - F

1 Material

End Connections

SS = 316 stainless steel

2 Hose

NGS = NG series single nylon hose (Ω)

3 Nominal Hose Size, in.

4 = 1/4

6 = 3/8

4 End Connections

See **End Connection Designator** column in tables on page 70.

For fitting dimensions, see **End Connection** tables, page 70.

5 Overall Length

Insert length in inches.

6 Options

For multiple options, add designators in alphanumeric order with a dash between each designator.

F = Fire jacket

F1 = Thermosleeve

X = No spring guards^①

^① 6 in. spring guards at each end are standard. The **X** option should only be used in static bend applications.

See page 83 for detailed descriptions of options.

NG Series Nylon Hose

Ordering Information and Dimensions

Custom Hose Assemblies—Twin and Vent Hoses

Build a hose assembly ordering number by combining the designators in the sequence shown below.

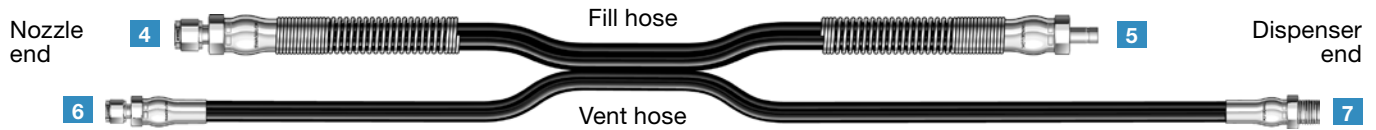

Typical Ordering Number

1 **2** **3** **4** **5** **6** **7** **8** **9** **10** **11**
 SS - NGV 6 - S6 T6 S4 P6 - 24 - 1 3 - X

1 **Material**

End Connections

SS = 316 stainless steel

2 **Hose**

NGT = NG series twin nylon hose (Ω)

NGV = NG series vent nylon hose (Ω)

3 **Nominal Fill Hose Size, in.**

4 = 1/4

6 = 3/8

4 **Fill Hose Nozzle End Connection**

5 **Fill Hose Dispenser End Connection**

6 **Vent Hose Nozzle End Connection**

7 **Vent Hose Dispenser End Connection**

See **End Connection Designator** column in tables on page 70.

For fitting dimensions, see **End Connection** tables, page 70.

8 **Overall Length (Fill and Vent)**

Insert length in inches.

9 **Vent Hose Nozzle End Length Adjustment**

Positive

X = None

1 = 2 in.

2 = 4 in.

3 = 6 in.

4 = 8 in.

5 = 10 in.

6 = 12 in.

7 = 15 in.

8 = 18 in.

9 = 21 in.

0 = 24 in.

Negative

X = None

A = 2 in.

B = 4 in.

C = 6 in.

D = 8 in.

E = 10 in.

F = 12 in.

G = 15 in.

H = 18 in.

J = 21 in.

K = 24 in.

Illustration shows adjustment 1.

10 **Vent Hose Dispenser End Length Adjustment**

Positive

X = None

1 = 2 in.

2 = 4 in.

3 = 6 in.

4 = 8 in.

5 = 10 in.

6 = 12 in.

7 = 15 in.

8 = 18 in.

9 = 21 in.

0 = 24 in.

Negative

X = None

A = 2 in.

B = 4 in.

C = 6 in.

D = 8 in.

E = 10 in.

F = 12 in.

G = 15 in.

H = 18 in.

J = 21 in.

K = 24 in.

Illustration shows adjustment 3.

11 **Spring Guards**

6 in. spring guards at each end are standard.

X = No spring guards

This option should only be used in static bend applications.

See next page for end connections.

NG Series Nylon Hose

End Connections

Swagelok Tube Fittings



Tube Fitting Size	Nominal Hose Size	End Connection Designator	Dimensions		
			A	Minimum Inside Diameter	Maximum Outside Dimension
Dimensions, in. (mm)					
1/4	1/4	S4	2.57 (65.3)	0.15 (3.8)	0.80 (20.3)
3/8	3/8	S6	2.94 (74.7)	0.24 (6.1)	0.87 (22.1)
Dimensions, mm (in.)					
8	1/4 in.	G8	65.5 (2.58)	3.8 (0.15)	20.3 (0.80)
10	3/8 in.	G1	74.9 (2.95)	6.1 (0.24)	22.1 (0.87)

Swagelok Tube Adapters



Tube Adapter Size	Nominal Hose Size	End Connection Designator	Dimensions		
			A	Minimum Inside Diameter	Maximum Outside Dimension
Dimensions, in. (mm)					
1/4	1/4	T4	2.48 (63.0)	0.15 (3.8)	0.80 (20.3)
3/8	1/4	T6	2.47 (62.7)	0.15 (3.8)	0.80 (20.3)
	3/8	T6	2.82 (71.6)	0.24 (6.1)	0.87 (22.1)
Dimensions, mm (in.)					
8	1/4 in.	E8	62.7 (2.47)	3.8 (0.15)	20.3 (0.80)
10	3/8 in.	E1	71.6 (2.82)	6.1 (0.24)	22.1 (0.87)

Male Pipe Threads, NPT and ISO/BSP Tapered (ISO 7)



NPT and ISO/BSP Tapered Size in.	Nominal Hose Size in.	End Connection Designator	Dimensions, in. (mm)		
			A	Minimum Inside Diameter	Maximum Outside Dimension
NPT					
1/4	1/4	P4	2.28 (57.9)	0.15 (3.8)	0.80 (20.3)
3/8	3/8	P6	2.65 (67.3)	0.24 (6.1)	0.87 (22.1)
ISO/BSP Tapered					
1/4	1/4	K4	2.28 (57.9)	0.15 (3.8)	0.80 (20.3)
3/8	3/8	K6	2.65 (67.3)	0.24 (6.1)	0.87 (22.1)

NYLON

7R and 8R Series Nylon Hose

Features

- SAE general-purpose, hydraulic, nylon hose.
- Smooth-bore nylon core.
- Size range of 1/4 to 1 in. and working pressures up to 5000 psig (344 bar).
- Internal fiber reinforcement enhances hose pressure rating.
- Smooth black polyurethane cover is perforated to prevent blistering.
- Polyurethane cover resists abrasion.
- Select 8R series hose assemblies are approved to ECE R110; see page 84 for more information.
- Designed for use in hydraulic applications where outgassing is a concern.
- Bulk hose and end connections available for field assembly; custom assemblies also available.
- Options include hose covers and spring guard. See page 83 for details.

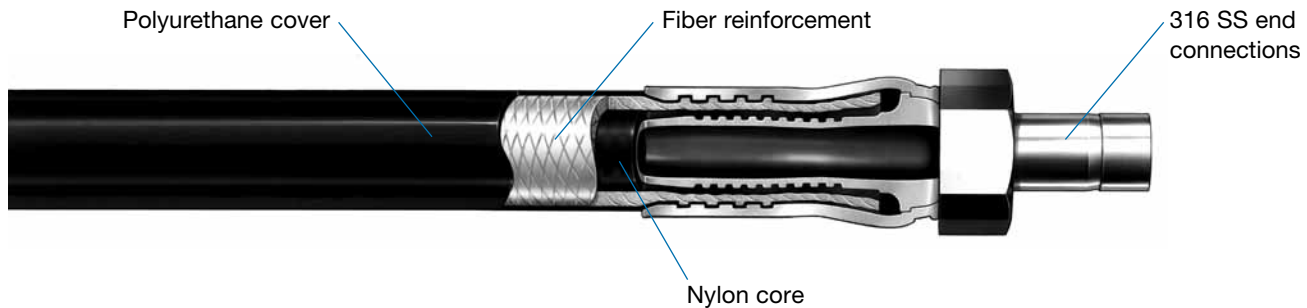

Technical Data

Specification (Series)	Nominal Hose Size in. (mm)	Inside Diameter in. (mm)	Outside Diameter in. (mm)	Minimum Inside Bend Radius in. (cm)	Temperature Range °F (°C)	Working Pressure at 70°F (20°C) psig (bar)	Burst Pressure at 70°F (20°C) psig (bar)	Bulk Hose Weight lb/ft (kg/m)
SAE J517 100R7 (7R series)	1/4 (6.4)	0.25 (6.4)	0.52 (13.2)	1.25 (3.18)	-40 to 200 (-40 to 93)	2750 (189)	11 000 (757)	0.07 (0.10)
	3/8 (9.6)	0.38 (9.8)	0.67 (17.0)	2.00 (5.08)		2250 (155)	9 000 (620)	0.10 (0.15)
	1/2 (12.7)	0.50 (12.7)	0.82 (20.8)	3.00 (7.62)		2000 (137)	8 000 (551)	0.14 (0.21)
SAE J517 100R8 (8R series)	1/4 (6.4) ^①	0.25 (6.4)	0.53 (13.5)	2.00 (5.08)	-40 to 200 (-40 to 93)	5000 (344)	20 000 (1378)	0.19 (0.28)
	3/8 (9.6)	0.38 (9.8)	0.67 (17.0)	2.50 (6.35)		4000 (275)	16 000 (1102)	0.11 (0.16)
	1/2 (12.7)	0.50 (12.7)	0.84 (21.3)	4.00 (10.2)		3500 (241)	14 000 (964)	0.15 (0.22)
	3/4 (19.0)	0.75 (19.0)	1.15 (29.2)	6.50 (16.5)		2250 (155)	9 000 (620)	0.26 (0.39)
	1 (25.4)	1.00 (25.4)	1.48 (37.6)	10.0 (25.4)		2000 (137)	8 000 (551)	0.39 (0.58)

① 1/4 in. (6.4 mm) size does not meet SAE J517 impulse cycle requirements at maximum temperature and minimum bend radius.

Cleaning and Packaging

Swagelok nylon hose components are cleaned in accordance with Swagelok *Standard Cleaning and Packaging (SC-10)*, MS-06-62. Each hose is bagged individually and boxed; longer hoses are coiled, bagged, and boxed.

Ordering Information and Dimensions

- For bulk hose for field assembly, see table below.
- For end connections for field assembly, see page 73.
- For custom hose assemblies, see page 76 for hose sizes, end connections, lengths, and options.
- For tools for field assembly, see page 86.

Bulk Hose

Select an ordering number.



Coils of nominal hose sizes smaller than 1 in. may contain up to three pieces of hose.

Hose Series	Nominal Hose Size, in.	Ordering Number	Reel Length ft (m)
7R	1/4	7R-4	250 (76)
	3/8	7R-6	
	1/2	7R-8	
8R	1/4	8R-4	250 (76)
	3/8	8R-6	
	1/2	8R-8	
	3/4	8R-12	125 (38)
	1	8R-16	50 (15)

7N and 8N Series Nylon Hose

Features

- SAE nonconductive, nylon hose.
- Smooth-bore nylon core.
- Size range of 1/4 to 3/4 in. and working pressures up to 2750 psig (189 bar).
- Internal fiber reinforcement enhances hose pressure rating.
- Smooth orange polyurethane cover is nonperforated to prevent moisture from entering hose.
- Polyurethane cover resists abrasion.
- Hose meets electrical conductivity requirements of SAE J343/SAE J517. Hose is not intended for exposure to continuous electrical current.
- Designed for use with petroleum-based and synthetic hydraulic fluids where SAE nonconductive properties are desired.
- Bulk hose and end connections available for field assembly; custom assemblies also available.
- Options include hose covers and spring guards. See page 83 for details.

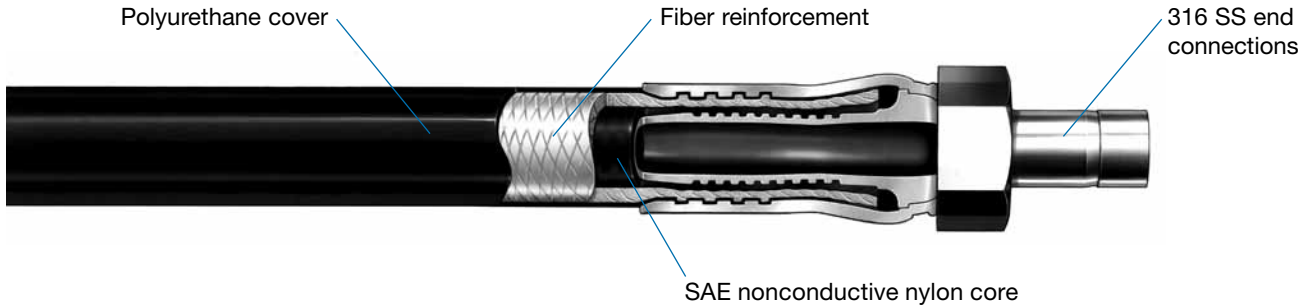

Technical Data

Specification (Series)	Nominal Hose Size in. (mm)	Inside Diameter in. (mm)	Outside Diameter in. (mm)	Minimum Inside Bend Radius in. (cm)	Temperature Range °F (°C)	Working Pressure at 70°F (20°C) psig (bar)	Burst Pressure at 70°F (20°C) psig (bar)	Bulk Hose Weight lb/ft (kg/m)
SAE J517 100R7 (7N series)	1/4 (6.4)	0.26 (6.5)	0.49 (12.4)	1.25 (3.18)	-40 to 200 (-40 to 93)	2750 (189)	11 000 (757)	0.07 (0.10)
	3/8 (9.6)	0.38 (9.8)	0.65 (16.5)	2.00 (5.08)		2250 (155)	9 000 (620)	0.10 (0.15)
	1/2 (12.7)	0.50 (12.7)	0.80 (20.3)	3.00 (7.62)		2000 (137)	8 000 (551)	0.14 (0.21)
SAE J517 100R8 (8N series)	3/4 (19.0)	0.75 (19.0)	1.15 (29.2)	6.50 (16.5)	-40 to 200 (-40 to 93)	2250 (155)	9 000 (620)	0.26 (0.39)

Cleaning and Packaging

Swagelok nylon hose components are cleaned in accordance with Swagelok *Standard Cleaning and Packaging (SC-10)*, MS-06-62. Each hose is bagged individually and boxed; longer hoses are coiled, bagged, and boxed.

- ⚠ **Caution:** System media can be conduits for electricity. Consider system media properties prior to use.
- ⚠ Nonperforated covers may blister in gas service.

Ordering Information and Dimensions

- For bulk hose for field assembly, see table below.
- For end connections for field assembly, see page 73.
- For custom hose assemblies, see page for 76 for hose sizes, end connections, lengths, and options.
- For tools for field assembly, see page 86.

Bulk Hose

Select an ordering number.



Coils of nominal hose sizes smaller than 1 in. may contain up to three pieces of hose.

Hose Series	Nominal Hose Size, in.	Ordering Number	Reel Length ft (m)
7N	1/4	7N-4	250 (76)
	3/8	7N-6	
	1/2	7N-8	
8N	3/4	8N-12	125 (38)

7R, 8R, 7N, and 8N Series Nylon Hose and 7P Series Polyethylene Hose

End Connections

Select an ordering number.

To determine the cut length of bulk hose for field assembly, subtract dimension *B* for each end connection from the desired overall length.

For field assembly, also select the corresponding pusher and die ordering numbers. See tables on page 87.

Examples: **MS-P-TA4** and **MS-7R8R-4**

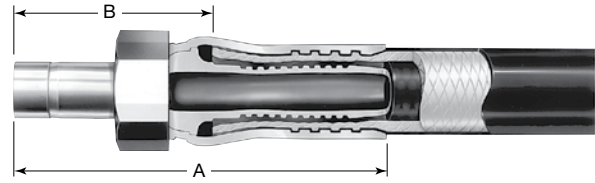

Swagelok Tube Adapters

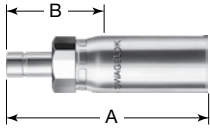

Tube Adapter Size	Nominal Hose Size	Ordering Number	Dimensions				End Connection Designator
			A	B	Minimum Inside Diameter	Maximum Outside Dimension	
Dimensions, in. (mm)							
1/4	1/4	SS-TP4-TA4	2.48 (63.0)	1.45 (36.8)	0.15 (3.8)	0.80 (20.3)	TA4
3/8	1/4	SS-TP4-TA6	2.47 (62.7)	1.44 (36.6)	0.15 (3.8)	0.80 (20.3)	TA6
	3/8	SS-TP6-TA6	2.82 (71.6)	1.51 (38.4)	0.24 (6.1)	0.87 (22.1)	TA6
1/2	1/2	SS-TP8-TA8	3.40 (86.4)	1.84 (46.7)	0.36 (9.1)	1.09 (27.6)	TA8
5/8	1/2	SS-TP8-TA10	3.40 (86.4)	1.84 (46.7)	0.39 (9.9)	1.09 (27.6)	TA10
3/4	3/4	SS-TP12-TA12	3.70 (94.0)	1.95 (49.5)	0.56 (14.2)	1.31 (33.1)	TA12
1	1	SS-TP16-TA16	4.47 (113)	2.26 (57.4)	0.76 (19.3)	1.60 (40.5)	TA16
Dimensions, mm (in.)							
6	1/4 in.	SS-TP4-TM6	63.0 (2.48)	36.8 (1.45)	3.8 (0.15)	20.3 (0.80)	TM6
8	1/4 in.	SS-TP4-TM8	62.7 (2.47)	36.6 (1.44)	3.8 (0.15)	20.3 (0.80)	TM8
10	3/8 in.	SS-TP6-TM10	71.6 (2.82)	38.4 (1.51)	6.1 (0.24)	22.1 (0.87)	TM10
12	1/2 in.	SS-TP8-TM12	86.4 (3.40)	46.7 (1.84)	9.1 (0.36)	27.6 (1.09)	TM12

Swagelok Tube Fittings

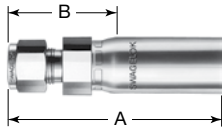

Tube Fitting Size	Nominal Hose Size	Ordering Number	Dimensions				End Connection Designator
			A	B	Minimum Inside Diameter	Maximum Outside Dimension	
Dimensions, in. (mm)							
1/4	1/4	SS-TP4-SL4	2.57 (65.3)	1.54 (39.1)	0.15 (3.8)	0.80 (20.3)	SL4
3/8	3/8	SS-TP6-SL6	2.94 (74.7)	1.63 (41.4)	0.24 (6.1)	0.87 (22.1)	SL6
1/2	1/2	SS-TP8-SL8	3.30 (83.8)	1.74 (44.2)	0.36 (9.1)	1.09 (27.6)	SL8
Dimensions, mm (in.)							
6	1/4 in.	SS-TP4-SM6	65.3 (2.57)	39.1 (1.54)	3.8 (0.15)	20.3 (0.80)	SM6
8	1/4 in.	SS-TP4-SM8	65.5 (2.58)	39.4 (1.55)	3.8 (0.15)	20.3 (0.80)	SM8
10	1/4 in.	SS-TP4-SM10	71.9 (2.83)	45.7 (1.80)	3.8 (0.15)	22.1 (0.87)	SM10
	3/8 in.	SS-TP6-SM10	74.9 (2.95)	41.7 (1.64)	6.1 (0.24)	22.1 (0.87)	SM10
12	1/2 in.	SS-TP8-SM12	83.8 (3.30)	44.2 (1.74)	9.1 (0.36)	27.6 (1.09)	SM12

NYLON

See next page for more end connections.

7R, 8R, 7N, and 8N Series Nylon Hose and 7P Series Polyethylene Hose

Male Pipe Threads, NPT and ISO/BSP Tapered (ISO 7)

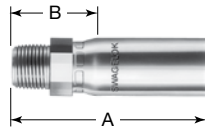

NPT and ISO/BSP Tapered Size in.	Nominal Hose Size in.	Ordering Number	Dimensions, in. (mm)				End Connection Designator
			A	B	Minimum Inside Diameter	Maximum Outside Dimension	
NPT							
1/4	1/4	SS-TP4-PM4	2.28 (57.9)	1.25 (31.8)	0.15 (3.8)	0.80 (20.3)	PM4
	3/8	SS-TP6-PM4	2.65 (67.3)	1.34 (34.0)	0.24 (6.1)	0.87 (22.1)	PM4
3/8	3/8	SS-TP6-PM6	2.65 (67.3)	1.34 (34.0)	0.24 (6.1)	0.87 (22.1)	PM6
1/2	1/2	SS-TP8-PM8	3.09 (78.5)	1.53 (38.9)	0.36 (9.1)	1.09 (27.6)	PM8
ISO/BSP Tapered							
1/4	1/4	SS-TP4-MT4	2.28 (57.9)	1.25 (31.8)	0.15 (3.8)	0.80 (20.3)	MT4
3/8	3/8	SS-TP6-MT6	2.65 (67.3)	1.34 (34.0)	0.24 (6.1)	0.87 (22.1)	MT6
1/2	1/2	SS-TP8-MT8	3.09 (78.5)	1.53 (38.9)	0.36 (9.1)	1.09 (27.6)	MT8

Male ISO/BSP Parallel Threads with 60° Male Cone (ISO 228)

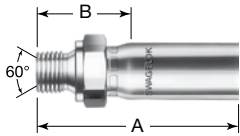

ISO/BSP Parallel, 60° Male Cone Size in.	Nominal Hose Size in.	Ordering Number	Dimensions, in. (mm)				End Connection Designator
			A	B	Minimum Inside Diameter	Maximum Outside Dimension	
1/4	1/4	SS-TP4-MS4	2.53 (64.3)	1.50 (38.1)	0.15 (3.8)	0.80 (20.3)	MS4
3/8	3/8	SS-TP6-MS6	2.73 (69.3)	1.42 (36.1)	0.24 (6.1)	0.87 (22.1)	MS6
1/2	1/2	SS-TP8-MS8	3.00 (76.2)	1.44 (36.6)	0.36 (9.1)	1.23 (31.3)	MS8

SAE 37° (JIC) Female Swivel

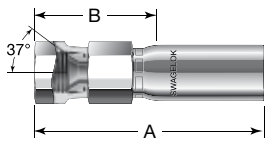

Swivel Size in.	Nominal Hose Size in.	Ordering Number	Dimensions, in. (mm)				End Connection Designator
			A	B	Minimum Inside Diameter	Maximum Outside Dimension	
1/4	1/4	SS-TP4-AS4	2.62 (66.6)	1.59 (40.4)	0.15 (3.8)	0.80 (20.3)	AS4
3/8	3/8	SS-TP6-AS6	3.03 (77.0)	1.71 (43.4)	0.24 (6.1)	0.87 (22.1)	AS6
1/2	1/2	SS-TP8-AS8	3.34 (84.8)	1.77 (45.0)	0.36 (9.1)	1.09 (27.6)	AS8

Dimensions shown with swivel nut pushed toward hex.

Female Swivel ISO/BSP Parallel Threads with 60° Cone

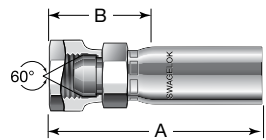

Swivel ISO/BSP Parallel Thread, 60° Cone Size in.	Nominal Hose Size in.	Ordering Number	Dimensions, in. (mm)				End Connection Designator
			A	B	Minimum Inside Diameter	Maximum Outside Dimension	
1/4	1/4	SS-TP4-BM4	2.45 (62.2)	1.42 (36.1)	0.15 (3.8)	0.87 (22.1)	BM4
3/8	3/8	SS-TP6-BM6	2.87 (72.9)	1.56 (39.6)	0.24 (6.1)	1.02 (25.8)	BM6
1/2	1/2	SS-TP8-BM8	3.23 (82.0)	1.67 (42.4)	0.36 (9.1)	1.23 (31.3)	BM8

Dimensions shown with swivel nut pushed toward hex.

7R, 8R, 7N, and 8N Series Nylon Hose and 7P Series Polyethylene Hose

Female Swivel ISO/BSP Parallel Threads with 30° Cone

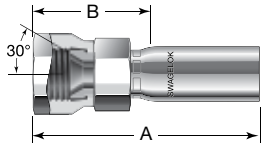

Swivel ISO/BSP Parallel Thread, 30° Cone Size in.	Nominal Hose Size in.	Ordering Number	Dimensions, in. (mm)				End Connection Designator
			A	B	Minimum Inside Diameter	Maximum Outside Dimension	
1/4	1/4	SS-TP4-BS4	2.56 (65.0)	1.53 (38.9)	0.15 (3.8)	0.87 (22.1)	BS4
3/8	3/8	SS-TP6-BS6	3.00 (76.2)	1.69 (42.9)	0.24 (6.1)	1.02 (25.8)	BS6
1/2	1/2	SS-TP8-BS8	3.38 (85.9)	1.81 (46.0)	0.36 (9.1)	1.23 (31.3)	BS8

Dimensions shown with swivel nut pushed toward hex.

Universal Globe Seal, Metric Female Swivel Nut

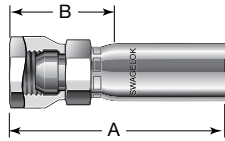

Universal Globe Seal, Metric Female Swivel Nut Size mm	Nominal Hose Size in.	Ordering Number	Dimensions, in. (mm)				End Connection Designator
			A	B	Minimum Inside Diameter	Maximum Outside Dimension	
14	1/4	SS-TP4-MC14	2.38 (60.5)	1.35 (34.3)	0.15 (3.8)	0.87 (22.1)	MC14
18	3/8	SS-TP6-MC18	2.77 (70.4)	1.46 (37.1)	0.24 (6.1)	1.02 (25.8)	MC18
22	1/2	SS-TP8-MC22	3.08 (78.2)	1.51 (38.4)	0.36 (9.1)	0.80 (20.3)	MC22

Dimensions shown with swivel nut pushed toward hex.

See next page for custom hose assemblies.

7R, 8R, 7N, 8N Series Nylon Hose

Ordering Information

Custom Hose Assemblies

Build a hose assembly ordering number by combining the designators in the sequence shown below.



Typical Ordering Number

1 2 3 4 4 5 6 5 6
SS - 7R 4 TA 4 PM 4 - 28 F or **71 CM - F**
in. cm

1 Material

End Connections

SS = 316 stainless steel

2 Hose

7R = 7R series SAE 100R7 nylon hose
(1/4, 3/8, and 1/2 in. sizes only)

8R = 8R series SAE 100R8 nylon hose

7N = 7N series SAE 100R7
nonconductive nylon hose
(1/4, 3/8, and 1/2 in. sizes only)

8N = 8N series SAE 100R8
nonconductive nylon hose
(3/4 in. size only)

3 Nominal Hose Size, in.

4 = 1/4 (7R, 8R, 7N series only)

6 = 3/8 (7R, 8R, 7N series only)

8 = 1/2 (7R, 8R, 7N series only)

12 = 3/4 (8R, 8N series only)

16 = 1 (8R series only)

4 End Connections

See **End Connection Designator**
column in tables on pages 73 to
75.

Add designators in reverse
alphanumeric order.

5 Overall Length

Inches or centimeters, in whole
numbers. Include **CM** as shown for
centimeter lengths.

6 Options

For multiple options, add designators in
alphanumeric order with a dash between
each designator. For hose lengths
specified in centimeters, insert a dash as
shown prior to the first option designator.

CRN = Lanyard tag with CRN

F = Fire jacket

F1 = Thermosleeve

S = 302 SS spring guard, hose-
length

S2 = 302 SS spring guard, 6-in.
length (1/4 and 3/8 in. sizes only)

T = Lanyard tag

T2 = Two lanyard tags

W = Hydrostatic test

093 = ECE R110 approval

(See page 84 for the nominal
sizes and end connections
available.)

Specify text for tags. See **Hose Tag
Text** table, page 84.

See page 83 for detailed descriptions
of options.

7P Series—Polyethylene Hose

Features

- Polyethylene hose designed for use in food, dairy, and water applications.
- Smooth-bore polyethylene core.
- Size range of 1/4 to 1 in. and working pressures up to 2750 psig (189 bar).
- Internal fiber reinforcement enhances hose pressure rating.
- Smooth, polyurethane blue cover is nonperforated to prevent moisture entrapment and system contamination.
- Polyurethane cover resists abrasion.
- Polyethylene core material is compliant with FDA 21 CFR Part 177.1520 and NSF-51, for use with food, dairy, and water.
- Bulk hose and end connections available for field assembly; custom assemblies also available.
- Options include hose covers and spring guards. See page 83 for details.

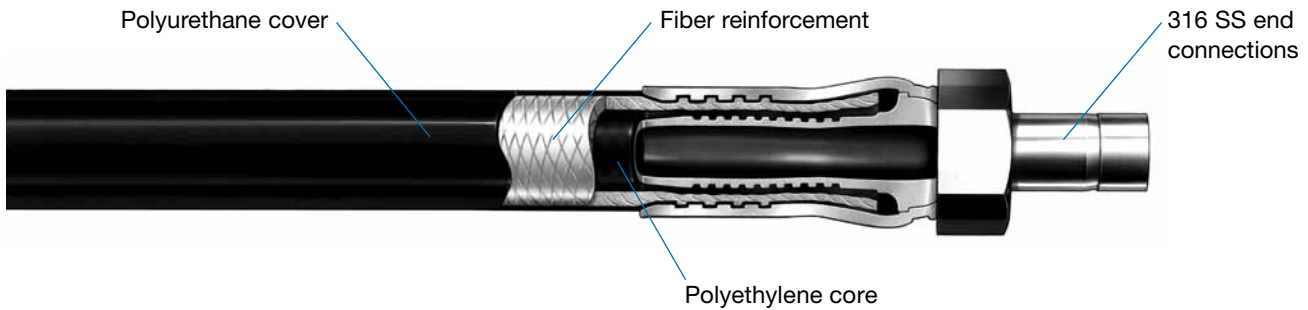

Technical Data

Nominal Hose Size in. (mm)	Inside Diameter in. (mm)	Outside Diameter in. (mm)	Minimum Inside Bend Radius in. (cm)	Temperature Range °F (°C)	Working Pressure at 70°F (20°C) psig (bar)	Burst Pressure at 70°F (20°C) psig (bar)	Bulk Hose Weight lb/ft (kg/m)
1/4 (6.4)	0.25 (6.4)	0.52 (13.2)	1.25 (3.18)	-10 to 150 (-23 to 65)	2750 (189)	11 000 (757)	0.06 (0.09)
3/8 (9.7)	0.38 (9.7)	0.66 (16.8)	2.00 (5.08)		2250 (155)	9 000 (620)	0.09 (0.13)
1/2 (12.7)	0.50 (12.7)	0.81 (20.6)	3.00 (7.62)		2000 (137)	8 000 (551)	0.12 (0.18)
3/4 (19.0)	0.75 (19.0)	1.14 (29.0)	5.00 (12.7)		1500 (103)	6 000 (413)	0.25 (0.37)
1 (25.4)	1.00 (25.4)	1.48 (37.6)	8.00 (20.3)		1500 (103)	6 000 (413)	0.37 (0.55)

Cleaning and Packaging

Swagelok polyethylene hose components are cleaned in accordance with Swagelok *Standard Cleaning and Packaging (SC-10)*, MS-06-62. Each hose is bagged individually and boxed; longer hoses are coiled, bagged, and boxed.

⚠ Caution:
Nonperforated covers may blister in gas service.

Ordering Information and Dimensions

- For bulk hose for field assembly, see table below.
- For end connections for field assembly, see page 73.
- For custom hose assemblies, see page for 78 for hose sizes, end connections, lengths, and options.
- For tools for field assembly, see page 86.

Bulk Hose

Select an ordering number.



Coils of nominal hose sizes smaller than 1 in. may contain up to three pieces of hose.

Hose Series	Nominal Hose Size, in.	Ordering Number	Reel Length ft (m)
7P	1/4	7P-4	250 (76)
	3/8	7P-6	
	1/2	7P-8	
	3/4	7P-12	125 (38)
	1	7P-16	50 (15)

See next page for custom hose assemblies.

7P Series Polyethylene Hose

Ordering Information

Custom Hose Assemblies

Build a hose assembly ordering number by combining the designators in the sequence shown below.



Typical Ordering Number

1 2 3 4 4 5 6 5 6
 SS - 7 P 4 T A 4 P M 4 - 28 F or 71 CM - F
in. cm

1 Material

End Connections

SS = 316 stainless steel

2 Hose

7P = 7P series polyethylene hose

3 Nominal Hose Size, in.

4 = 1/4
 6 = 3/8
 8 = 1/2
 12 = 3/4
 16 = 1

4 End Connections

See **End Connection Designator** column in tables on pages 73 to 75.

Add designators in reverse alphanumeric order.

5 Overall Length

Inches or centimeters, in whole numbers. Include **CM** as shown for centimeter lengths.

6 Options

For multiple options, add designators in alphanumeric order with a dash between each designator. For hose lengths specified in centimeters, insert a dash as shown prior to the first option designator.

CRN = Lanyard tag with CRN

F = Fire jacket

F1 = Thermosleeve

S = 302 SS spring guard, hose-length

S2 = 302 SS spring guard, 6-in. length (1/4 and 3/8 in. sizes only)

T = Lanyard tag

T2 = Two lanyard tags

W = Hydrostatic test

Specify text for tags. See **Hose Tag Text** table, page 84.

See page 83 for detailed descriptions of options.

PB Series Rubber Hose

Features

- Ozone-resistant, general-purpose rubber hose with push-on connections.
- Smooth-bore Buna N core.
- Size range of 1/4 to 1 in. and working pressures up to 350 psig (24.1 bar).
- Internal fiber reinforcement enhances hose pressure rating and ensures connection retention.
- Buna N cover resists abrasion.
- Cover is flame-resistant in accordance with 30CFR Part 18.
- Designed for use in general-purpose, compressed air applications and oil transfer.
- Bulk hose and end connections available for field assembly; custom assemblies also available.
- Standard hose color is blue; other hose colors include black, green, gray, red, and yellow.
- Options include tags. See page 83 for details.

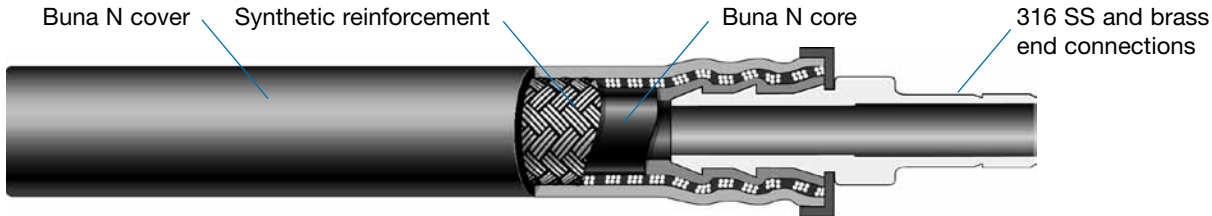

Technical Data

Nominal Hose Size in. (mm)	Inside Diameter in. (mm)	Outside Diameter in. (mm)	Minimum Inside Bend Radius in. (cm)	Temperature Range °F (°C)	Working Pressure at -40 to 70°F (-40 to 20°C) psig (bar)	Burst Pressure at 70°F (20°C) psig (bar)	Bulk Hose Weight lb/ft (kg/m)
1/4 (6.4)	0.26 (6.6)	0.51 (12.8)	2.50 (6.35)	-40 to 200 (-40 to 93)	350 (24.1)	1400 (96.4)	0.09 (0.13)
3/8 (9.7)	0.39 (9.9)	0.67 (17.0)	3.00 (7.62)		300 (20.6)	1200 (82.6)	0.14 (0.20)
1/2 (12.7)	0.50 (12.7)	0.75 (19.0)	5.00 (12.7)		300 (20.6)	1200 (82.6)	0.14 (0.20)
3/4 (19.0)	0.76 (19.3)	1.07 (27.2)	7.00 (17.8)		300 (20.6)	1200 (82.6)	0.25 (0.37)
1 (25.4)	1.00 (25.4)	1.34 (34.0)	8.00 (20.3)	-20 to 200 (-28 to 93)	300 (20.6)	1200 (82.6)	0.33 (0.49)

Pressure-Temperature Ratings

Ratings maintain a minimum factor of 4:1 between working pressure and minimum burst pressure.

Nominal Hose Size, in.	1/4	3/8, 1/2, 3/4	1
Temperature, °F (°C)	Working Pressure, psig (bar)		
-40 (-40)	350 (24.1)	300 (20.6)	—
-20 (-28) to 70 (20)	350 (24.1)	300 (20.6)	300 (20.6)
100 (37)	315 (21.7)	270 (18.6)	270 (18.6)
150 (65)	210 (14.4)	180 (12.4)	180 (12.4)
200 (93)	100 (6.8)	80 (5.5)	80 (5.5)

Cleaning and Packaging

Swagelok PB series rubber hose components are cleaned in accordance with Swagelok *Standard Cleaning and Packaging (SC-10)*, MS-06-62. Each custom hose assembly is bagged individually and boxed; longer hoses are coiled, bagged, and boxed. Bulk rubber hose is packaged and shipped in reels.

⚠ Users must evaluate compatibility in systems containing heated water-based fluids—some conditions may affect the Buna N core.

See next page for ordering information.

PB Series Rubber Hose

Ordering Information and Dimensions

- For bulk hose, see below; for end connections for field assembly, see below.
- For custom hose assemblies, see page 82 for hose sizes, end connections, lengths, and options.
- For hose cutters for field assembly, see page 85.
- For a push-on tool for field assembly, see page 86.

Bulk Hose

Bulk hose is available in 250 ft (76 m) reels; the standard color is blue. Select an ordering number from the table below left.

Example: **PB-4**

For hose of a color other than blue, add a hose color designator from the table below right.

Example **PB-4-BK**

Nominal Hose Size in.	Ordering Number
1/4	PB-4
3/8	PB-6
1/2	PB-8
3/4	PB-12
1	PB-16

Rubber Hose Color	Designator
Black	-BK
Gray	-GY
Green	-GR
Red	-RD
Yellow	-YW



Reels contain up to three lengths of hose.

End Connections

Select a basic ordering number and add **SS** for 316 SS or **B** for brass.

Example: **SS-PB4-SL4**

To determine the cut length of bulk hose for field assembly, subtract dimension *B* for each end connection from the desired overall length.

For field assembly instructions, see *PB Series Rubber Hose Assembly and Disassembly*, MS-CRD-0125 and *Push-On Tool User's Manual*, MS-CRD-0190.

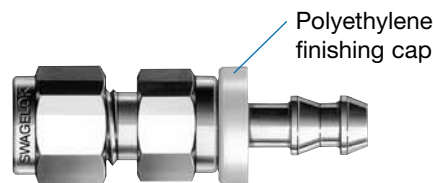

1 in. size (PB16) does not have a finishing cap.

Swagelok Tube Fittings

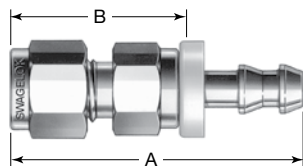

Tube Fitting Size in.	Nominal Hose Size in.	Basic Ordering Number	Dimensions, in. (mm)				End Connection Designator
			A	B	Minimum Inside Diameter	Maximum Outside Dimension	
1/4	1/4	-PB4-SL4	1.97 (50.0)	1.14 (29.0)	0.15 (3.8)	0.67 (17.0)	SL4
3/8	3/8	-PB6-SL6	2.11 (53.6)	1.17 (29.7)	0.26 (6.6)	0.87 (22.1)	SL6
1/2	1/2	-PB8-SL8	2.47 (62.7)	1.37 (34.8)	0.36 (9.1)	1.02 (25.8)	SL8

PB Series Rubber Hose

Swagelok Tube Adapters

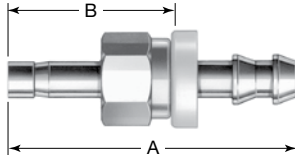

Tube Adapter Size	Nominal Hose Size	Basic Ordering Number	Dimensions				End Connection Designator
			A	B	Minimum Inside Diameter	Maximum Outside Dimension	
Dimensions, in. (mm)							
1/4	1/4	-PB4-TA4	1.93 (49.0)	1.10 (27.9)	0.15 (3.8)	0.58 (14.7)	TA4
3/8	3/8	-PB6-TA6	2.03 (51.6)	1.09 (27.7)	0.24 (6.1)	0.72 (18.3)	TA6
1/2	1/2	-PB8-TA8	2.47 (62.7)	1.37 (34.8)	0.34 (8.6)	0.86 (21.8)	TA8
3/4	3/4	-PB12-TA12	3.14 (79.8)	1.43 (36.3)	0.57 (14.5)	1.22 (31.0)	TA12
1	1	-PB16-TA16	4.13 (105)	1.90 (48.3)	0.79 (20.1)	1.58 (40.1)	TA16
Dimensions, mm (in.)							
6	1/4 in.	-PB4-TM6	49.0 (1.93)	27.9 (1.10)	3.8 (0.15)	14.7 (0.58)	TM6
8	1/4 in.	-PB4-TM8	48.8 (1.92)	27.7 (1.09)	3.8 (0.15)	14.7 (0.58)	TM8
	3/8 in.	-PB6-TM8	52.1 (2.05)	28.2 (1.11)	5.6 (0.22)	18.3 (0.72)	TM8
10	3/8 in.	-PB6-TM10	51.6 (2.03)	27.7 (1.09)	6.9 (0.27)	18.3 (0.72)	TM10
12	1/2 in.	-PB8-TM12	62.7 (2.47)	34.7 (1.38)	8.1 (0.32)	21.8 (0.86)	TM12
18	3/4 in.	-PB12-TM18	79.8 (3.14)	36.3 (1.43)	13.7 (0.54)	31.0 (1.22)	TM18
25	1 in.	-PB16-TM25	105 (4.13)	48.3 (1.90)	19.8 (0.78)	40.1 (1.58)	TM25

Male Pipe Threads, NPT and ISO/BSP Tapered (ISO 7)

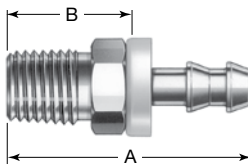

NPT and ISO/BSP Tapered Size in.	Nominal Hose Size in.	Basic Ordering Number	Dimensions, in. (mm)				End Connection Designator
			A	B	Minimum Inside Diameter	Maximum Outside Dimension	
NPT							
1/4	1/4	-PB4-PM4	1.68 (42.7)	0.85 (21.6)	0.15 (3.8)	0.65 (16.5)	PM4
	3/8	-PB6-PM4	1.80 (45.7)	0.86 (21.8)	0.27 (6.9)	0.79 (20.1)	PM4
3/8	3/8	-PB6-PM6	1.80 (45.7)	0.86 (21.8)	0.27 (6.9)	0.79 (20.1)	PM6
1/2	1/2	-PB8-PM8	2.19 (55.6)	1.09 (27.7)	0.37 (9.4)	1.01 (25.7)	PM8
3/4	3/4	-PB12-PM12	2.81 (71.4)	1.10 (27.9)	0.61 (15.5)	1.29 (32.8)	PM12
1	1	-PB16-PM16	3.78 (96.0)	1.55 (39.4)	0.79 (20.1)	1.58 (40.1)	PM16
ISO/BSP Tapered							
1/4	1/4	-PB4-MT4	1.68 (42.7)	0.85 (21.6)	0.15 (3.8)	0.65 (16.5)	MT4
3/8	3/8	-PB6-MT6	1.80 (45.7)	0.86 (21.8)	0.27 (6.9)	0.79 (20.1)	MT6
1/2	1/2	-PB8-MT8	2.19 (55.6)	1.09 (27.7)	0.37 (9.4)	1.01 (25.7)	MT8
3/4	3/4	-PB12-MT12	2.81 (71.4)	1.10 (27.9)	0.61 (15.5)	1.29 (32.8)	MT12
1	1	-PB16-MT16	3.78 (96.0)	1.55 (39.4)	0.79 (20.1)	1.58 (40.1)	MT16

Unions

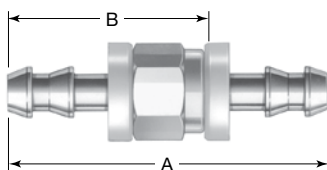

Nominal Hose Size in.	Basic Ordering Number	Dimensions, in. (mm)			
		A	B	Minimum Inside Diameter	Maximum Outside Dimension
1/4	-PB4-6	2.07 (52.6)	1.24 (31.5)	0.15 (3.8)	0.58 (14.7)
3/8	-PB6-6	2.25 (57.2)	1.31 (33.3)	0.27 (6.9)	0.72 (18.3)
1/2	-PB8-6	2.61 (66.3)	1.51 (38.4)	0.37 (9.4)	0.86 (21.8)
3/4	-PB12-6	3.86 (98.0)	2.14 (54.4)	0.61 (15.5)	1.22 (31.0)

See next page for custom hose assemblies.

Swagelok

PB Series Rubber Hose

Ordering Information

Custom Hose Assemblies

Build a hose assembly ordering number by combining the designators in the sequence shown below.



Typical Ordering Number

1 2 3 4 4 5 6 5 6 7
SS - PB 4 TA 4 PM 4 - 28 - BK or **71 CM - BK - CRN**
in. cm

1 Material

End Connections

SS = 316 stainless steel

B = Brass

2 Hose

PB = PB series rubber hose

3 Nominal Hose Size, in.

4 = 1/4

6 = 3/8

8 = 1/2

12 = 3/4

16 = 1

4 End Connections

See **End Connection Designator** column in tables on pages 80 and 81.

Add designators in reverse alphanumeric order.

5 Overall Length

Inches or centimeters, in whole numbers. Include **CM** as shown for centimeter lengths.

6 Hose Color

None = Blue, standard hose color

BK = Black

GR = Green

GY = Gray

RD = Red

YW = Yellow

7 Options

For multiple options, add designators in alphanumeric order with a dash between each designator.

CRN = Lanyard tag with CRN

T = Lanyard tag

T2 = Two lanyard tags

W = Hydrostatic test

Specify text for tags. See **Hose Tag Text** table, page 84.

See page 83 for detailed descriptions of options.

Options

Covers

Covers do not change hose technical data.

Fire Jacket (Option F)

- Woven fiberglass coated with specially compounded aerospace-grade silicone rubber.
- Resists many hydraulic fluids and lubricating oils.
- Provides insulation from internal system fluid temperature extremes.
- Operating temperature: -65 to 500°F (-53 to 260°C) with short-term flame exposure to 2000°F (1093°C).



Thermosleeve (Option F1)

- Braided fiberglass with saturated synthetic material coating.
- Creates a barrier that prevents direct contact with the hose and resists abrasion.
- Protects hose from weld splatter and resists effects of UV light.
- Operating temperature: up to 1000°F (537°C).



Armor Guard (Option A)

- Interlocking, flexible 302 stainless steel.
- Highly flexible, protects against kinking and abrasion.
- Covers entire length of hose.
- Operating temperature: -325 to 750°F (-200 to 398°C).



Spiral Guard (Options G6, G7, and G8)

- Helical HDPE plastic.
- Highly flexible, protects against abrasion.
- Covers entire length of hose.
- Operating temperature: -180 to 250°F (-117 to 121°C).
- Standard colors are blue, black, and yellow.



316 Stainless Steel Material (Option Z)

- Replaces standard 304 stainless steel overbraid with 316L stainless steel and 300 series stainless steel collar with 316 stainless steel.
- Provides greater corrosion resistance.



Spring Guard (Options S and S2)

- Helical 302 stainless steel.
- Highly flexible, protects against kinking and abrasion.
- Hose-length version covers entire length of hose (option S).
- Six-inch-long version protects each end of hose (option S2).
- Operating temperature: -325 to 850°F (-200 to 454°C).



Hose-Length Spring Guard



6-in. Long Spring Guard

Testing

These tests are in addition to the standard testing performed on each hose series.

Helium Leak Testing (Option H7)

- Inboard helium leak tested to a maximum leak rate of 1×10^{-7} std cm³/s.
- Test certification included with order.

Hydrostatic Testing (Option W)

- Hydrostatic pressure test to 1.5 times the rated working pressure of the hose at 70°F (20°C) with no visible leakage.
- Test certification included with order.
- Customer-specified testing is available; contact your authorized Swagelok representative.

Nitrogen Pressure Testing (Option N3)

- Nitrogen gas bubble leak test at 200 psig (13.7 bar), not to exceed 1.5 times the rated working pressure of the hose at 70°F (20°C) with no visible leakage.
- Test certification included with order.
- Customer-specified testing is available; contact your authorized Swagelok representative.

See next page for tags and approval options.

Options

Tags

Lanyard Tag (Option T)

- Stainless steel tag with customer-specified text. See **Hose Tag Text** table for details.
- Attached to the hose with a stainless steel lanyard and aluminum clamp.
- Specify a quantity of 1 or 2.



Lanyard Tag with CRN (Option CRN)

- Stainless steel tag with customer-provided, national or provincial Canadian Registration Number (CRN number).
- Attached to the hose with a stainless steel lanyard and aluminum clamp.

Clamp Tag (Option T5)

- Stainless steel tag with customer-specified text.
- See **Hose Tag Text** table for details. Limited to 2 lines of text.
- Attached to the hose with two metal bands.



Mat Tag (Option M_)

- Polyester tag with customer-specified text. See **Hose Tag Text** table for details.
- Operating temperature range: –40 to 302°F (–40 to 150°C)
- Attached to the hose with an adhesive.
- Standard colors are black, blue, brown, gray, green, orange, pink, purple, red, white, and yellow.



Perma Tag (Option P_)

- Polyester tag encapsulated in platinum-cured silicone with customer-specified text. See **Hose Tag Text** table for details.
- Attached to the hose with an adhesive.
- Designed for sterilization-in-place (SIP), clean-in-place (CIP), and autoclave applications.
- Standard colors are black, blue, brown, gray, green, orange, pink, purple, red, white, and yellow.



Hose Tag Text

Specify up to 5 lines of text with 25 characters per line including spaces and commas.

Exception: Clamp tag is limited to 2 lines of text.

Line Number	For Example
1.	Ordering number
2.	Process line
3.	Location
4.	Supplier phone number
5.	Date of manufacture

Approvals

Alternative Fuels-Type Approval (Option 093)

Select T series hose assemblies and 8R series hose assemblies are available tested, tagged, and approved to ECE R110. See the table for the nominal sizes and end connections available.

T Series Carbon Black-Filled PTFE Hose Assemblies:

- Operating temperature –40 to 248°F (–40 to 120°C)
- Maximum working pressure 435 psig (30 bar); pressure classification 1.

8R Series Hose Assemblies:

- Operating temperature –40 to 185°F (–40 to 85°C)
- Maximum working pressure 3770 psig (260 bar); pressure classification 0.

End Connection	Hose Nominal Size		
	1/4 in.	3/8 in.	1/2 in.
Fractional Swagelok tube fitting	SL4, SL5	SL6	SL6, SL8, SL10
Metric Swagelok tube fitting	SM6, SM8	SM8, SM10	SM10, SM12, SM16
Fractional Swagelok tube adapter	TA4, TA5	TA6	TA6, TA8, TA10
Metric Swagelok tube adapter	TM6, TM8	TM8, TM10	TM10, TM12, TM16
Male NPT	PM4	PM4, PM6	PM6, PM8
Male ISO/7	MT4	MT4, MT6	MT6, MT8
Male JIC (AN) 37° flare	AN4	AN6	AN8
Male SAE/MS (ECE R110-approved O-ring)	ST2, ST4	ST4, ST6, ST8	ST6, ST8, ST10

Options

Availability

Availability of options by hose series is shown below, but may be limited by hose size.

Applications, hose operating parameters, and hose length must be considered when selecting options.

Options		Hose Series																			
		FM	FJ	FL	CT	T	B	X	S	C	N	W	F	U	NG	7R	8R	7N	8N	7P	PB
Covers	Fire jacket	✓	✓	✓		✓	✓	✓	✓	✓	✓	✓	✓	✓	✓	✓	✓	✓	✓	✓	✓
	Thermosleeve	✓	✓	✓		✓									✓	✓	✓	✓	✓	✓	✓
	Armor guard							✓	✓	✓	✓	✓	✓	✓							
	Spiral guard							✓	○	✓	✓	✓	✓	✓							
	Spring guard—Hose length	○				✓										✓	✓	✓	✓	✓	✓
	Spring guard—6 in. long														Std	○	○	○		○	
	316L SS braid	Std	✓			○															
Testing	Helium leak testing	✓	✓	✓	✓																
	Hydrostatic testing	✓	✓	✓		✓										✓	✓	✓	✓	✓	✓
	Nitrogen pressure testing	✓	✓	✓		✓															
Tags	Lanyard tag	✓	✓	✓		✓	✓	✓	✓	✓	✓	✓	✓	✓	✓	✓	✓	✓	✓	✓	✓
	Two lanyard tags	✓	✓	✓		✓	✓	✓	✓	✓	✓	✓	✓	✓		✓	✓	✓	✓	✓	✓
	Lanyard tag, CRN	✓	✓	✓	✓	✓										✓	✓	✓	✓	✓	✓
	Clamp tag		✓																		
	Mat tag						✓	✓	✓	✓	✓	✓	✓	✓							
	Perma tag								○			✓		✓							
Approval	Alternative fuels-type ECE R110					○											○				
Hose Core		Metal				Fluoropolymer										Nylon				Polyethylene	Rubber

- ✓ Available in all sizes.
- Available in select hose sizes.

Tools and Accessories

Cutting Tool for Hose and Soft Tubing

Use to cut nylon, polyethylene, or rubber hose, as well as vinyl or PFA tubing to the desired length for field assembly.



- Cuts hose and tubing up to 1 in. nominal size.

Ordering number: **MS-HC-SC-1A**

Replacement blade ordering number: **MS-HC-SC-1A-BLD**

See next page for assembly tools for nylon, polyethylene, and rubber hose.

Tools and Accessories

Assembly Tools for Nylon, Polyethylene, and Rubber Hose

Hand Swager

Portable, manually operated tool for attaching end connections to nylon and polyethylene hose.



- Attaches Swagelok end connections to 1/4 to 1 in. hose.
- Constructed of rugged, die-cast aluminum.
- Can be bench mounted.
- Weight: 8 lb (3.6 kg).

Ordering number: **MS-HSR**

For more information, see the *Swagelok Hand Swager User's Manual*, MS-13-211.



Case

Can accommodate hand swager and other tools and accessories.

Ordering number: **MS-HSR-CASE**

Power Swager

Stationary, electrically powered tool for attaching end connections to nylon and polyethylene hose.



- Attaches Swagelok end connections to 1/4 to 1 in. hose.
- Bench mounting required.
- 30 in. (76 cm) H, 19 in. (48 cm) W, 28 in. (71 cm) D; 140 lb (64 kg); Single-phase motor, 1 hp, 60 Hz, 115/208/230 V.

Ordering number: **MS-PSR-110**

For more information, see the *Swagelok Power Swager Manual and Thermoplastic Hose Assembly Instructions* user's manual, MS-13-144.

⚠ The Swagelok power swager is designed expressly for swaging Swagelok end connections and hose using the appropriate Swagelok dies and pushers. Swagelok Company cannot be responsible for property damage or personal injury that may result from swaging other brands of end connections and hose, nor from the intentional misuse of the swager.

Push-On Tool

Portable, manually operated tool for inserting end connections into nylon, polyethylene, and rubber hose.



- Inserts end connections into 1/4 to 1 in. hose.
- Bench mounting required.
- 10 in. (25 cm) H, 14 in. (36 cm) W, 28 in. (71 cm) D; 35 lb (15.9 kg).

Ordering number: **MS-SPOT**

For more information, see the *Swagelok Push-On Tool User's Manual*, MS-CRD-0190.

Accessories for Hand and Power Swagers

Swage Dies

Use to attach end connections to nylon and polyethylene hose.



Ordering numbers based on nominal hose size. See **Pushers and Swage Dies for Nylon and Polyethylene Hose** tables, page 87.

Pushers

Use to push and position end connections while swaging, and used with vise blocks to assist in inserting end connections into nylon and polyethylene hose.



Ordering numbers based on nominal hose size. See **Pushers and Swage Dies for Nylon and Polyethylene Hose** tables, page 87.

Lubricant

Use to lubricate the swage collar and swage dies during swaging of nylon and polyethylene hose end connections.



Ordering number: **MS-TP-LUBE**

Depth Insertion Gauges

Use to mark nylon and polyethylene hose to proper fitting insertion depth.



Ordering numbers:

MS-IGB-1 for hose size designators 4, 6, and 8

MS-IGB-2 for hose size designators 12 and 16.

Vise Blocks

Use to clamp nylon and polyethylene hose during end connection insertion.



Ordering numbers:

MS-VB-1 for hose size designators 4, 6, and 8

MS-VB-2 for hose size designators 12 and 16.

Tools and Accessories

Pushers and Swage Dies for Nylon and Polyethylene Hose

Swagelok Tube Adapters

Tube Adapter Size	Nominal Hose Size	Pusher Ordering Number	Swage Die Ordering Number
Dimensions, in.			
1/4	1/4	MS-P-TA4	MS-7R8R-4
3/8	1/4	MS-P-4TA6	MS-7R8R-4
	3/8	MS-P-TA6	MS-7R8R-6
1/2	1/2	MS-P-SLTA8	MS-7R8R-8
5/8	1/2	MS-P-8TA10	MS-7R8R-8
3/4	3/4	MS-P-TA12	MS-8R-12
1	1	MS-P-TA16	MS-8R-16 / MS-7P-16
Dimensions, mm			
6	1/4 in.	MS-P-TA4	MS-7R8R-4
8	1/4 in.	MS-P-4TM8	MS-7R8R-4
10	3/8 in.	MS-P-TA6	MS-7R8R-6
12	1/2 in.	MS-P-SLTA8	MS-7R8R-8

Swagelok Tube Fittings

Tube Fitting Size	Nominal Hose Size	Pusher Ordering Number	Swage Die Ordering Number
Dimensions, in.			
1/4	1/4	MS-P-SL4	MS-7R8R-4
3/8	3/8	MS-P-SL6	MS-7R8R-6
1/2	1/2	MS-P-SLTA8	MS-7R8R-8
Dimensions, mm			
6	1/4 in.	MS-P-SL4	MS-7R8R-4
8	1/4 in.	MS-P-4SM8	MS-7R8R-4
10	1/4 in.	MS-P-4SM10	MS-7R8R-4
	3/8 in.	MS-P-SL6	MS-7R8R-6
12	1/2 in.	MS-P-SLTA8	MS-7R8R-8

SAE 37° (JIC) Female Swivel

Swivel Size in.	Nominal Hose Size in.	Pusher Ordering Number	Swage Die Ordering Number
1/4	1/4	MS-P-AS4	MS-7R8R-4
3/8	3/8	MS-P-AS6	MS-7R8R-6
1/2	1/2	MS-P-AS8	MS-7R8R-8

Male Pipe Threads, NPT and ISO/BSP Tapered (ISO 7)

NPT and ISO/BSP Tapered Size in.	Nominal Hose Size in.	Pusher Ordering Number	Swage Die Ordering Number
1/4	1/4	MS-P-PM4	MS-7R8R-4
	3/8	MS-P-PM6	MS-7R8R-6
3/8	3/8	MS-P-PM6	MS-7R8R-6
1/2	1/2	MS-P-PM8	MS-7R8R-8

Male ISO/BSP Parallel Threads with 60° Male Cone (ISO 228)

ISO/BSP Parallel, 60° Male Cone Size in.	Nominal Hose Size in.	Pusher Ordering Number	Swage Die Ordering Number
1/4	1/4	MS-P-MS4	MS-7R8R-4
3/8	3/8	MS-P-MS6	MS-7R8R-6
1/2	1/2	MS-P-MS8	MS-7R8R-8

Female Swivel ISO/BSP Parallel Threads with 60° Cone

Swivel ISO/BSP Parallel Thread, 60° Cone Size in.	Nominal Hose Size in.	Pusher Ordering Number	Swage Die Ordering Number
1/4	1/4	MS-P-BM4	MS-7R8R-4
3/8	3/8	MS-P-BM6	MS-7R8R-6
1/2	1/2	MS-P-BM8	MS-7R8R-8

Female Swivel ISO/BSP Parallel Threads with 30° Female Cone

Swivel ISO/BSP Parallel Thread, 30° Cone Size in.	Nominal Hose Size in.	Pusher Ordering Number	Swage Die Ordering Number
1/4	1/4	MS-P-BS4	MS-7R8R-4
3/8	3/8	MS-P-BS6	MS-7R8R-6
1/2	1/2	MS-P-BS8	MS-7R8R-8

Universal Globe Seal, Metric Female Swivel Nut

Universal Globe Seal, Metric Female Swivel Nut Size mm	Nominal Hose Size in.	Pusher Ordering Number	Swage Die Ordering Number
14	1/4	MS-P-MC14	MS-7R8R-4
18	3/8	MS-P-MC18	MS-7R8R-6
22	1/2	MS-P-MC22	MS-7R8R-8

Additional Products

Tube Fittings

See the Swagelok *Gaugeable Tube Fittings and Adapter Fittings* catalog, MS-01-140, for more information.



Pipe Fittings

See the Swagelok *Pipe Fittings* catalog, MS-01-147, for more information.



Quick-Connects

See the Swagelok *Quick-Connects* catalog, MS-01-138, for more information.



See SAE J1273, *Recommended Practices for Hydraulic Hose Assemblies*, for information on installation and use of hose.

www.sae.org

Safe Product Selection

When selecting a product, the total system design must be considered to ensure safe, trouble-free performance. Function, material compatibility, adequate ratings, proper installation, operation, and maintenance are the responsibilities of the system designer and user.

Caution: Do not mix or interchange parts with those of other manufacturers.

Warranty Information

Swagelok products are backed by The Swagelok Limited Lifetime Warranty. For a copy, visit swagelok.com or contact your authorized Swagelok representative.

Swagelok, Ultra-Torr, VCO, VCR—TM Swagelok Company
© 2009–2013 Swagelok Company
Printed in U.S.A., AGS
October 2013, R8
MS-01-180